

## Omnipolar Switch Hall-Effect IC Basics

### Introduction

There are four general categories of Hall-effect IC devices that provide a digital output: unipolar switches, bipolar switches, omnipolar switches, and latches. Omnipolar switches are described in this application note. Similar application notes on bipolar switches, unipolar switches, and latches are provided on the Allegro™ website.

Omnipolar Hall-effect sensor ICs, often referred to as “omnipolar switches,” are a type of digital output Hall-effect latching switches that operate with either a strong positive or strong negative magnetic field. This simplifies application assembly because the operating magnet can be mounted with either pole toward the omnipolar device. A single magnet presenting a field of sufficient strength (magnetic flux density) will cause the device to switch to

its on state. After it has been turned-on, the omnipolar IC will remain turned-on until the magnetic field is removed and the IC reverts to its off state. It latches the changed state and remains turned-off, until a magnetic field of sufficient strength is again presented.

An application for detecting the position of a vehicle gear-shift lever is shown in figure 1. The gear-shift lever incorporates a magnet (the purple cylinder). The line of miniature black boxes is an array of omnipolar switch devices. When the vehicle operator moves the lever, the magnet is moved past the individual Hall devices. The devices near the magnet are subjected to the magnetic field and are turned-on, but more remote devices are not affected and remain turned-off. Either the south pole or the north pole of the magnet can be oriented toward the Hall devices, and the branded face of the Hall device package is toward the magnet.

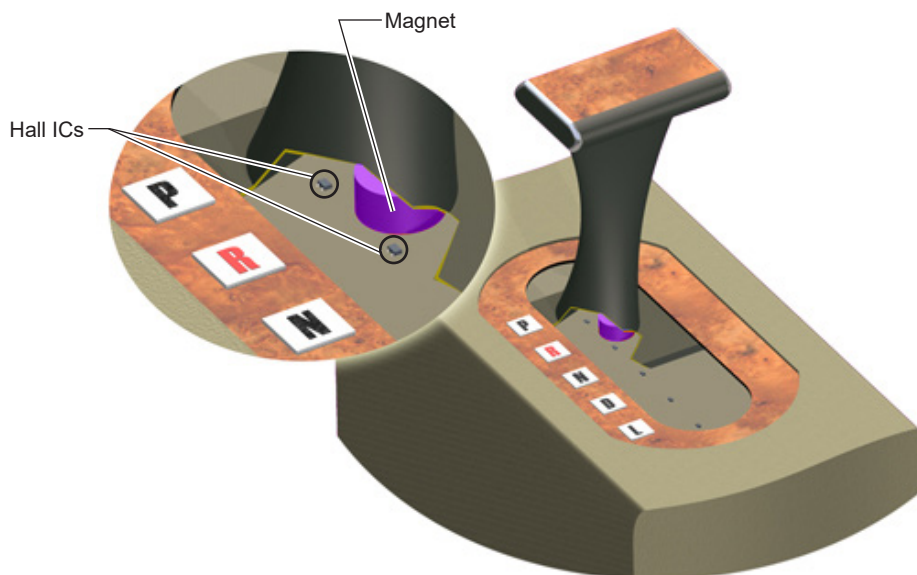

Figure 1. An application using omnipolar switch sensor ICs. The ultra-small Hall ICs switch as the magnet (purple cylinder) moves past them during gear-shifting.

## Magnetic Switch Point Terms

The following are terms used to define the transition points, or switch points, of Hall switch operation:

- **B**: The symbol for Magnetic Flux Density, the property of a magnetic field used to determine Hall device switch points. Measured in gauss (G) or tesla (T). The conversion is  $1 \text{ G} = 0.1 \text{ mT}$ .

**B** can have a north or south polarity, so it is useful to keep in mind the algebraic convention, by which **B** is indicated as a negative value for north-polarity magnetic fields, and as a positive value for south-polarity magnetic fields. This convention allows arithmetic comparison of north and south polarity values, where the relative strength of the field is indicated by the absolute value of **B**, and the sign indicates the polarity of the field. For example, a  $-100 \text{ G}$  (north) field and a  $100 \text{ G}$  (south) field have equivalent strength, but opposite polarity. In the same way, a  $-100 \text{ G}$  field is stronger than a  $-50 \text{ G}$  field.

- **B<sub>OP</sub>**: Magnetic operate point; the level of a strengthening magnetic field at which a Hall device switches on. The result-

ing state of the device output depends on the individual device electronic design.

- **B<sub>RP</sub>**: Magnetic release point; the level of a weakening magnetic field at which a Hall device switches off (or for some types of Hall devices, the level of a strengthening negative field given a positive **B<sub>OP</sub>**). The resulting state of the device output depends on the individual device electronic design.
- **B<sub>HYS</sub>**: Magnetic switch point hysteresis. The transfer function of a Hall device is designed with this offset between the switch points to filter out small fluctuations in the magnetic field that can result from mechanical vibration or electromagnetic noise in the application.  $B_{HYS} = |B_{OP} - B_{RP}|$ .

## Typical Operation

The switch point ranges of omnipolar sensor ICs are symmetrical around the neutral field level,  $B = 0 \text{ G}$ , as shown in figure 3. The switch points are at equivalent field strengths, but at opposite polarities. For example, assume the positive (south) polarity switch points were operate point,  $B_{OP(S)}$ ,  $60 \text{ G}$ , and release point,

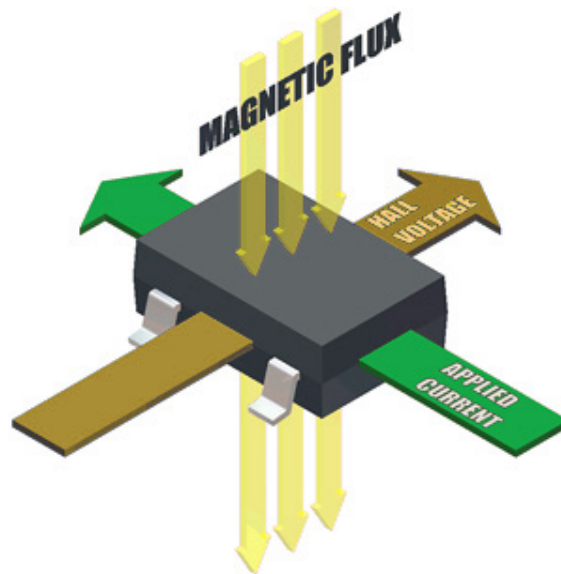

Figure 2. The Hall effect refers to the measurable voltage present when an applied current is influenced by a perpendicular magnetic field.

$B_{RP(S)}$ , 30 G. Then the negative (north) polarity switch points would be operate point,  $B_{OP(N)}$ , -60 G, and release point,  $B_{RP(N)}$ , -30 G. Latching the latest state prevents the devices from switching while subject to weak fields.

An omnipolar switch turns on in a strong magnetic field of either polarity, and the resulting output signal can be either at logic high (up to full supply voltage,  $V_{CC}$ ) or logic low (at the output transistor saturation voltage,  $V_{OUT(sat)}$ , usually <200 mV), depending on the design of the device IC output stage. An omnipolar switch turns off in a moderate magnetic field, and the resulting output signal is the opposite of the polarity in the on state. Like other types of Hall digital switch, these devices do not switch while the

magnetic field strength is in the switch point hysteresis ranges,  $B_{HYS}$ . In addition, latching the switch state prevents the device from switching while the magnetic field is relatively weak, between the release points,  $B_{RP(N)}$  and  $B_{RP(S)}$ . It is not necessary for the 0 G point to be crossed before switching can occur again. A given switching event can be followed by a switching event of either the same or the opposite polarity.

Although the device could power-on with the magnetic flux density at any level, for purposes of explanation of figure 3, start at the far left, where the magnetic flux ( $B$ , on the horizontal axis) is more negative than the north polarity operate point,  $B_{OP(N)}$ . Here the device is on, and the output voltage ( $V_{OUT}$ , on the verti-

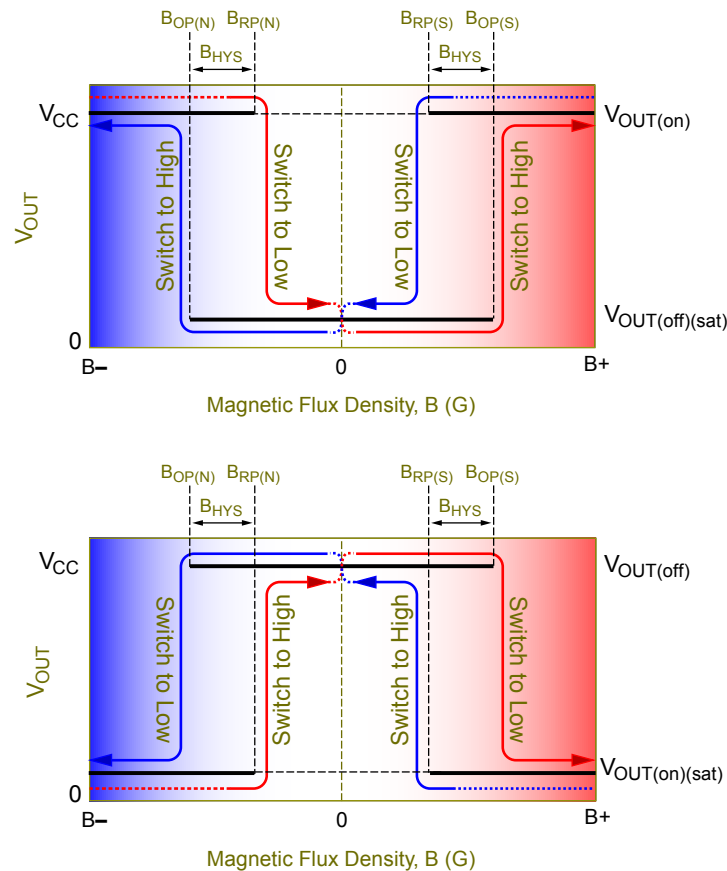

Figure 3. Omnipolar switch output characteristics. The top panel displays switching to logic high in the presence of a strong magnetic field, and the bottom panel displays switching to logic low, also in a strong magnetic field.

cal axis) depends on the device design: high (top panel), or low (bottom panel).

Following the arrows toward the right, the magnetic field becomes less negative. When the field is weaker than  $B_{RP(N)}$ , the device turns off. This causes the output voltage to change to the opposite state (either to high or to low, depending on the device design).

While the magnetic field remains weaker than  $B_{OP(N)}$  and  $B_{OP(S)}$  (near  $B = 0$  G, the center of figure 3), the device remains turned-off, and the latched output state remains unchanged. This is true even if  $B$  becomes slightly stronger than  $B_{RP(N)}$  or  $B_{RP(S)}$ , within the built-in zone of switching hysteresis,  $B_{HYS}$ .

At the next strong magnetic field, if it is positive, following the arrows toward the right, the magnetic field becomes more positive. When the field is stronger than  $B_{OP(S)}$ , the device turns on. This causes the output voltage to change to the opposite state (either to high or to low, depending on the device design). If instead the next strong magnetic field is negative, following the arrows toward the left, the magnetic field becomes more negative. When the field is stronger than  $B_{OP(N)}$ , the device turns on. This causes the output voltage to change back to the original state.

## Pull-Up Resistor

A pull-up resistor must be connected between the positive supply and the output pin (see figure 4). Common values for pull-up resistors are 1 to 10 k $\Omega$ . The minimum pull-up resistance is a function of the sensor IC maximum output current (sink current) and the actual supply voltage. 20 mA is a typical maximum output current, and in that case the minimum pull-up would be  $V_{CC} / 0.020$  A. In cases where current consumption is a concern, the pull-up resistance could be as large as 50 to 100 k $\Omega$ .

Caution: With large pull-up values it is possible to invite external leakage currents to ground, which are high enough to drop the output voltage even when the device is magnetically off. This is not a device problem but is rather a leakage that occurs in the conductors between the pull-up resistor and the sensor IC's output pin. Taken to the extreme, this can drop the sensor IC output voltage enough to inhibit proper external logic function.

## Use of Bypass Capacitors

Refer to figure 4 for a layout of bypass capacitors. In general:

- For designs without chopper stabilization: It is recommended that a 0.01  $\mu$ F capacitor be placed between the output and

ground pins and between the supply and ground pins.

- For designs with chopper stabilization: A 0.1  $\mu$ F capacitor must be placed between the supply and ground pins, and a 0.01  $\mu$ F capacitor is recommended between the output and ground pins.

## Power-On State

An omnipolar device powers-on in a valid state only if the magnetic field strength exceeds either  $B_{OP}$  or  $B_{RP}$  when power is applied. If the magnetic field strength is in the hysteresis band, that is between  $B_{OP}$  and  $B_{RP}$ , the device can assume either an on or off state initially, and then attains the correct state at the first excursion beyond a switch point. Devices can be designed with power-on logic that sets the device off until a switch point is reached.

## Power-On Time

Power-on time depends to some extent on the device design. Digital output sensor ICs, such as the latching device, reach stability on initial power-on in the following times.

Device type	Power-on time
Non-chopped designs	<4 $\mu$ s
Chopper-stabilized	<25 $\mu$ s

Basically, this means that prior to this elapsed time after provid-

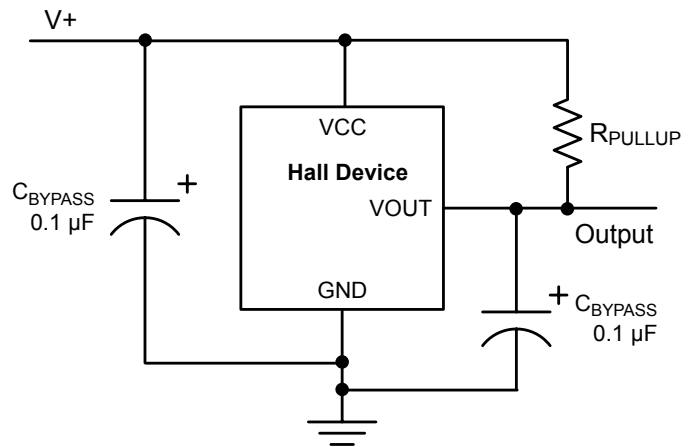

Figure 4. Typical application diagram.

ing power, device output may not be in the correct state, but after this time has elapsed, device output is guaranteed to be in the correct state.

## Power Dissipation

Total power dissipation is the sum of two factors:

- Power consumed by the sensor IC, excluding power dissipated in the output. This value is  $V_{CC}$  times the supply current.  $V_{CC}$  is the device supply voltage and the supply current is specified on the datasheet. For example, given  $V_{CC} = 12\text{ V}$  and Supply current = 9 mA. Power dissipation =  $12 \times 0.009$  or 108 mW.
- Power consumed in the output transistor. This value is  $V_{(on)(sat)}$  times the output current (set by the pull-up resistor). If  $V_{(on)(sat)}$  is 0.4 V (worst case) and the output current is 20 mA (often worst case), the power dissipated is  $0.4 \times 0.02 = 8\text{ mW}$ . As you can see, because of the very low saturation voltage the power dissipated in the output is not a huge concern.

Total power dissipation for this example is  $108 + 8 = 116\text{ mW}$ . Take this number to the derating chart in the datasheet for the package in question and check to see if the maximum allowable operational temperature must be reduced.

## Frequently Asked Questions

Q: How do I orient the magnets?

A: The magnet poles are oriented towards the branded face of the device. The branded face is where you will find the identification markings of the device, such as partial part number or date code.

Q: Can I approach the device back side with the magnet?

A: Yes, however bear this in mind: if the poles of the magnet remain oriented in the same direction, then the orientation of

the flux field through the device remains unchanged from the front-side approach (for example, if the south pole was nearer the device in the front-side approach, then the north pole would be nearer the device in the back-side approach). The north pole would then generate a positive field relative to the Hall element, while the south pole would generate a negative field.

Q: Are there trade-offs to approaching the device back side?

A: Yes. A “cleaner” signal is available when approaching from the package front side, because the Hall element is located closer to the front side (the package branded face) than to the back side. For example, for the “UA” package, the chip with the Hall element is 0.50 mm inside the branded face of the package, and so approximately 1.02 mm from the back-side face. (The distance from the branded face to the Hall element is referred to as the “active area depth.”)

Q: Can a very large field damage a Hall-effect device?

A: No. A very large field will not damage an Allegro Hall-effect device nor will such a field add additional hysteresis (other than the designed hysteresis).

Q: Why would I want a chopper-stabilized device?

A: Chopper-stabilized sensor ICs allow greater sensitivity with more-tightly controlled switch points than non-chopped designs. This may also allow higher operational temperatures. Most new device designs utilize a chopped Hall element.

## Possible Applications

- Cellular phones
- Cordless telephones
- Pagers
- Palmtop computers

---

## Suggested Devices

- Standard Allegro switches are listed in the selection guides on the company website, at <https://www.allegromicro.com/en/products/sense/switches-and-latches>
- Low-power switches are listed at <https://www.allegromicro.com/en/products/sense/switches-and-latches/micropower-switches-latches>

## Application Notes on Related Device Types

- <https://www.allegromicro.com/en/insights-and-innovations?type=Switch+and+Latch&topic=Application+Note&q=>

---

## REVISION HISTORY

Number	Date	Description
–	February 23, 2010	Initial release
1	November 10, 2021	Updated document template, links, and other minor editorial updates
2	October 30, 2023	Fixed broken link (page 6)

Copyright 2023, Allegro MicroSystems.

Allegro MicroSystems reserves the right to make, from time to time, such departures from the detail specifications as may be required to permit improvements in the performance, reliability, or manufacturability of its products. Before placing an order, the user is cautioned to verify that the information being relied upon is current.

Allegro's products are not to be used in any devices or systems, including but not limited to life support devices or systems, in which a failure of Allegro's product can reasonably be expected to cause bodily harm.

The information included herein is believed to be accurate and reliable. However, Allegro MicroSystems assumes no responsibility for its use; nor for any infringement of patents or other rights of third parties which may result from its use.

Copies of this document are considered uncontrolled documents.

For the latest version of this document, visit our website:

[www.allegromicro.com](http://www.allegromicro.com)