

XtremeSense™ 2D TMR Angle Sensor

FEATURES AND BENEFITS

- Angle error less than 0.60° (after one-time compensation) over full temperature range
- Dual full-bridge resistor network
- Operating magnetic field: 250 to 900 G
- Differential outputs for SIN and COS axes
- Supply voltage: 1.0 to 5.5 V
- AEC-Q100 Grade 1

APPLICATIONS

- Angular measurements
- Rotary and angular sensors
- BLDC motors

DESCRIPTION

The CT310 is a 2D angle sensor in a dual full-bridge configuration from Allegro developed on its patented XtremeSense™ 2D tunnel magnetoresistance (TMR) technology. The operating magnetic field for this 2D sensor is 250 to 900 G and has an angle error less than 0.60° over temperature following a one-time offset, gain, and phase compensation. The sensitive axes of the TMR elements are orthogonal to each other, providing a 90° phase separation between the sine and cosine outputs when measured differentially. This phase separation is inherently independent of magnet pole spacing and air gap.

The CT310 is available in an 8-lead TSSOP package, and for space-critical applications, a low-profile and small form factor 8-lead DFN package that is $2.00\text{ mm} \times 2.00\text{ mm} \times 0.45\text{ mm}$ in size. The packages are RoHS compliant and lead (Pb) free with a 100% matte-tin-plated leadframe.

PACKAGES

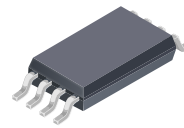

8-Lead TSSOP

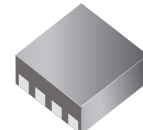

8-Lead DFN

Not to scale

FUNCTIONAL BLOCK DIAGRAM

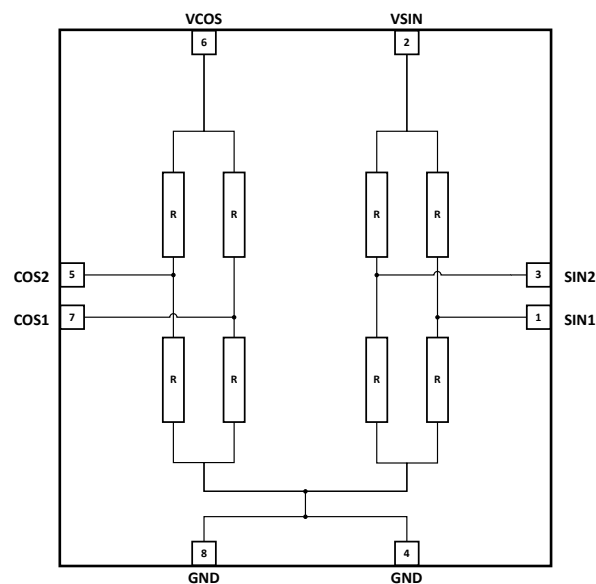

Figure 1: CT310 Functional Block Diagram

Table of Contents

Features and Benefits.....	1	Electrical Characteristics.....	6
Description.....	1	Recommended Application Circuit.....	8
Applications.....	1	Applications Information.....	9
Packages.....	1	Package Outline Drawings.....	10
Functional Block Diagram.....	1	Tape and Reel Pocket Drawings and Dimensions.....	12
Selection Guide.....	2	Package Information.....	14
Absolute Maximum Ratings.....	2	Revision History.....	15
Recommended Operating Conditions.....	2		
Pinout Diagrams and Terminal Lists.....	4		

SELECTION GUIDE

Part Number [1]	Operating Temp. Range (°C)	Automotive Grade	Output Type	Package	Packing
CT310LS-IT8	-40 to 85	-	Differential	8-lead TSSOP 6.40 mm × 3.05 mm × 1.10 mm	Tape and Reel
CT310LS-AT8	-40 to 125	Grade 1	Differential	8-lead TSSOP 6.40 mm × 3.05 mm × 1.10 mm	Tape and Reel
CT310LS-HD8	-40 to 125	-	Differential	8-lead DFN 2.00 mm × 2.00 mm × 0.45 mm	Tape and Reel



[1] Contact Allegro Microsystems for different temperature rated TSSOP-8 or DFN-8 package offerings or direct wafer sales.

ABSOLUTE MAXIMUM RATINGS [1]

Characteristic	Symbol	Notes	Rating	Unit
Forward Voltage	V_{COS}, V_{SIN}		6.0	V
Reverse Voltage	V_{RCOS}, V_{RSIN}		-0.3	V
Electrostatic Discharge Protection Level	ESD	Human Body Model (HBM) per JESD22-A114	±4.0 (min)	kV
		Charged Device Model (CDM) per JESD22-C101	±1.0 (min)	kV
Maximum Magnetic Field	B_{MAX}	≤5 minutes at $T_A = 25^{\circ}C$	±2000	G
Operating Ambient Temperature	T_A	Industrial	-40 to 85	°C
		Automotive (A), Extended Industrial (H)	-40 to 125	°C
Storage Temperature	T_{STG}		-65 to 165	°C
Lead Soldering Temperature	T_L	10 seconds	260	°C

[1] Stresses exceeding the absolute maximum ratings may damage the CT310 and may not function or be operable above the recommended operating conditions and stressing the parts to these levels is not recommended. In addition, extended exposure to stresses above the recommended operating conditions may affect device reliability. The absolute maximum ratings are stress ratings only.

THERMAL CHARACTERISTICS

Characteristic	Symbol	Test Conditions	Value	Unit
Junction-to-Ambient Thermal Resistance	$R_{\theta JA}$	TSSOP-8 package	234	°C/W

PINOUT DIAGRAMS AND TERMINAL LISTS

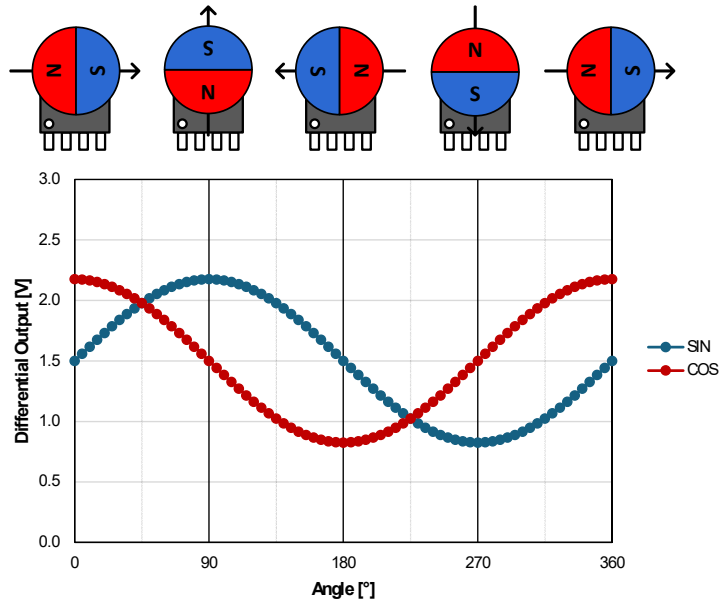

Figure 2: Nominal Differential Output, $V_{DD} = 3.0\text{ V}$

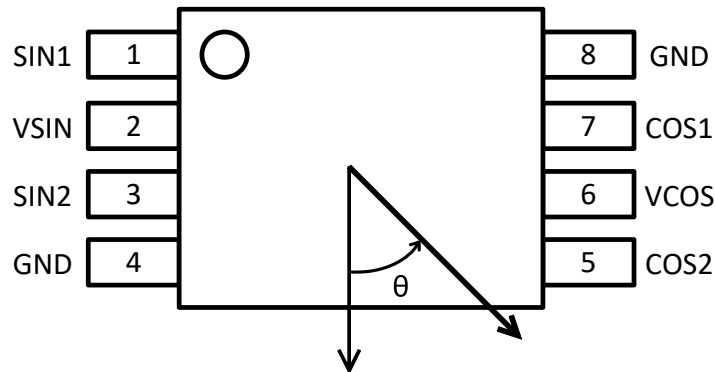

Figure 3: TSSOP-8 – Top-Down View

Terminal List

Number	Name	Function
1	SIN1 [1]	Differential output #1 for sine.
2	VSIN	Supply voltage for sine
3	SIN2 [1]	Differential output #2 for sine.
4	GND	Ground for sine.
5	COS2 [2]	Differential output #2 for cosine.
6	VCOS	Supply voltage for cosine
7	COS1 [2]	Differential output #1 for cosine.
8	GND	Ground for cosine.

[1] SIN2 – SIN1 = SIN.

[2] COS2 – COS1 = COS.

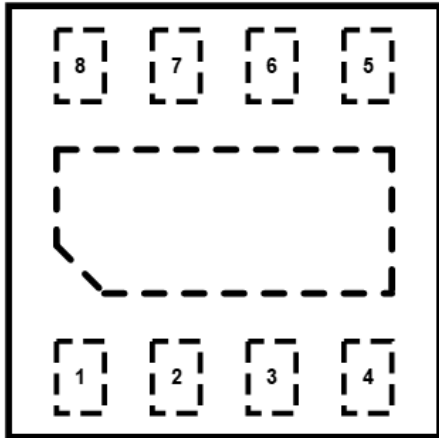

Figure 4: DFN-8, Top-Down View

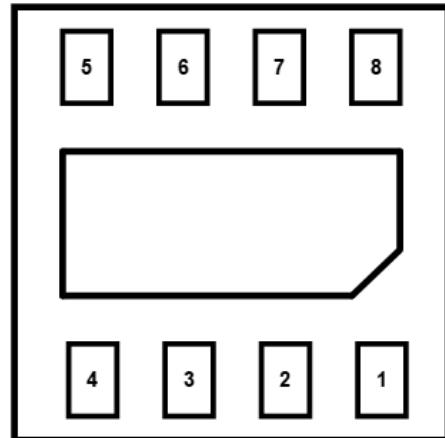

Figure 5: DFN-8, Bottom-Up View

Terminal List

Number	Name	Function
1	SIN1 [1]	Differential output #1 for sine.
2	VSIN	Supply voltage for sine
3	SIN2 [1]	Differential output #2 for sine.
4	GND	Ground for sine.
5	COS2 [2]	Differential output #2 for cosine.
6	VCOS	Supply voltage for cosine
7	COS1 [2]	Differential output #1 for cosine.
8	GND	Ground for cosine.

[1] SIN2 – SIN1 = SIN.

[2] COS2 – COS1 = COS.

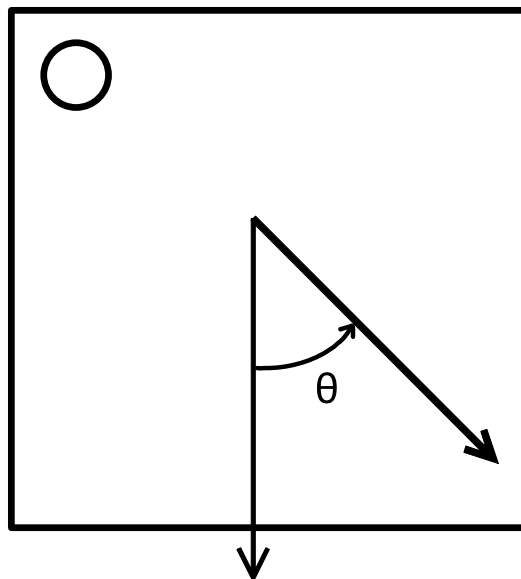

Figure 6: CT310 Axes of Sensitivity for DFN-8

ELECTRICAL CHARACTERISTICS: Valid over all operating voltage, temperature and field conditions, unless otherwise specified

Characteristics	Symbol	Test Conditions	Min.	Typ.	Max.	Unit
ELECTRICAL						
Supply Voltage Range	$V_{\text{COS}}, V_{\text{SIN}}$		1.0	–	5.5	V
Bridge Resistance [3]	R_{BRIDGE}	$T_A = 25^\circ\text{C}$	3.0	4.5	6.0	k Ω
Temperature Coefficient Resistance [1][3]	TCR		–	–0.05	–	%/ $^\circ\text{C}$
MAGNETIC						
Operating Magnetic Field	B		250	600	900	G
DIFFERENTIAL OUTPUTS						
Angle Error [2] [3]	θ_{ERR}	After one-time offset, amplitude, and orthogonality correction at 25°C, 0 hour	–	0.30	0.60	$^\circ$
Extended Range Angle Error [1] [2]	$\theta_{\text{ERR_EXT}}$	After one-time offset, amplitude, and orthogonality correction at 25°C, 0 hour, B = 200 G	–	–	0.90	$^\circ$
Angle Error Over Lifetime [4]	$\theta_{\text{ERR_LIFE}}$	After one-time offset, amplitude, and orthogonality correction at 25°C, 0hr over lifetime	–	–	1.0	$^\circ$
Angle Error Due to Hysteresis [1] [3]	$\theta_{\text{ERR_HYST}}$		–	0.03	–	$^\circ$
SIN, COS Differential Output Voltage Peak-to-Peak [3]	$V_{\text{SIN_D}}, V_{\text{COS_D}}$	$T_A = 25^\circ\text{C}$	0.35	0.45	0.50	V/V
Temperature Coefficient of Differential Output [1] [3]	TCV_{OUT}		–	–0.16	–	%/ $^\circ\text{C}$
SIN, COS Voltage Offset [3]	$V_{\text{OFF_SIN}}, V_{\text{OFF_COS}}$		–	± 1	± 5	mV/V
SIN, COS Amplitude Synchronism Ratio	k		97	100	103	%
Temperature Coefficient of Amplitude Synchronism [1] [3]	TC_k		–	± 0.005	–	%/ $^\circ\text{C}$
SIN, COS Orthogonality Error	$\text{OE}_{\text{SIN}}, \text{OE}_{\text{COS}}$	Deviation from ideal phase separation between SIN and COS	–2	0	2	$^\circ$
Noise [1] [3]	e_N	$f_{\text{BW}} = 1 \text{ Hz to } 10 \text{ kHz}, V_{\text{DD}} = 3.0 \text{ V}$	–	2.4	–	$\mu\text{V}_{\text{RMS}}/\text{V}$

[1] Determined by design and characterization; not tested in production.

[2] Hysteresis error and output noise are included in the Angular Error specification.

[3] Typical values represent 3 σ performance unless otherwise specified.

[4] Angle Error over Lifetime assumes the maximum observed angle error drift due to AEC-Q100 Grade 1 stress, relative to zero hour performance..

ELECTRICAL CHARACTERISTICS

$V_{DD} = 3.0\text{ V}$ and $T_A = 25^\circ\text{C}$ (unless otherwise specified)

Figures 8-12 show typical (mean, μ) performance over temperature and field to convey general performance trends for the identified specifications.

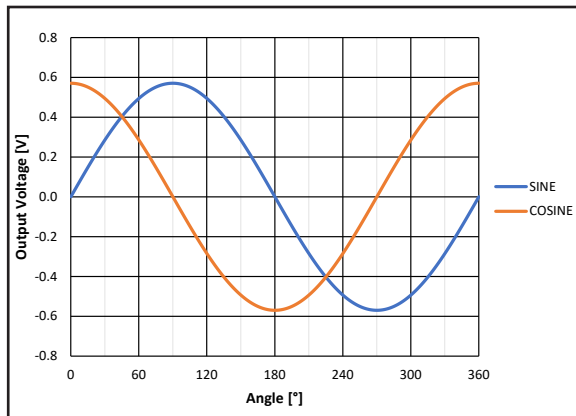

Figure 8: Output Voltage vs. Angle at B = 250 G

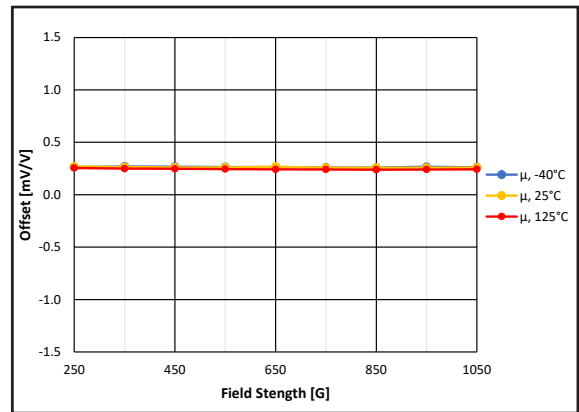

Figure 9: Voltage Offset (mV/V) over Field and Temp

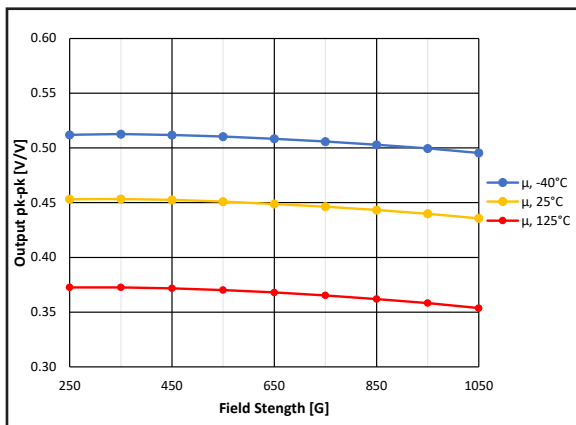

Figure 10: Differential Output Voltage (V/V) over Field and Temp

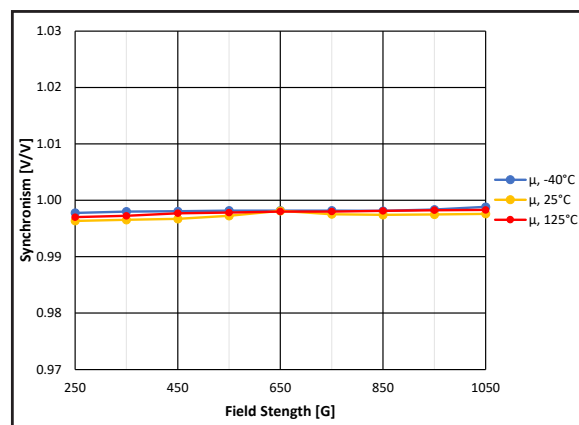

Figure 11: Amplitude Synchronism (V/V) over Field and Temperature

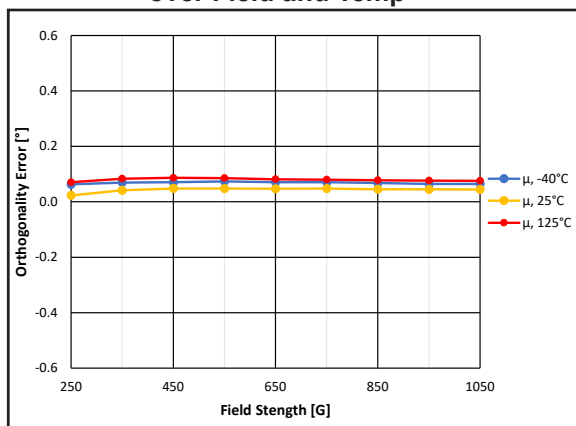

Figure 12: Orthogonality Error over Field and Temp

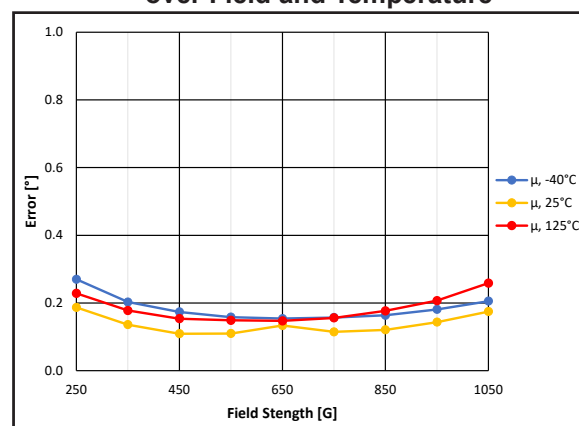

Figure 13: Angle Error After Compensation (25°C, 250 G) over Field and Temp

RECOMMENDED APPLICATION CIRCUIT

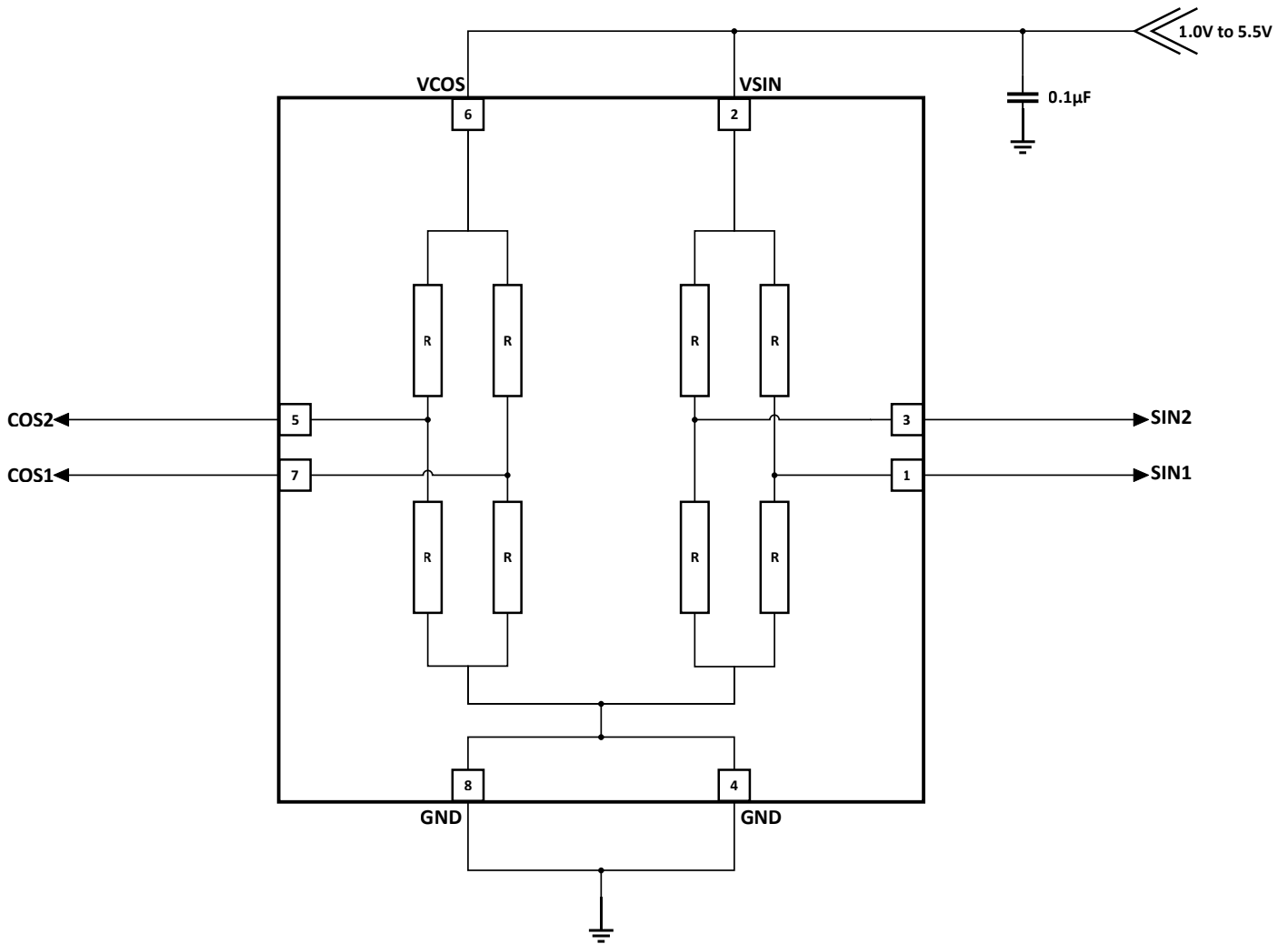

Figure 14: CT310 Application Diagram

Table 1: Recommended External Components

Component	Description	Parameter	Min.	Typ.	Max.	Unit
C _{BYP}	0.1 µF, X7R	C	–	0.1	–	µF

Applications Information

The XtremeSense TMR sensor location for the CT310 for the x, y dimensions are shown in Figure 15 and Figure 16 for the TSSOP-8 and DFN-8 packages respectively. Figure 17 and Figure 18 illustrates the location of the CT310 XtremeSense TMR sensor from the z dimension. All dimensions in the figures below are nominal.

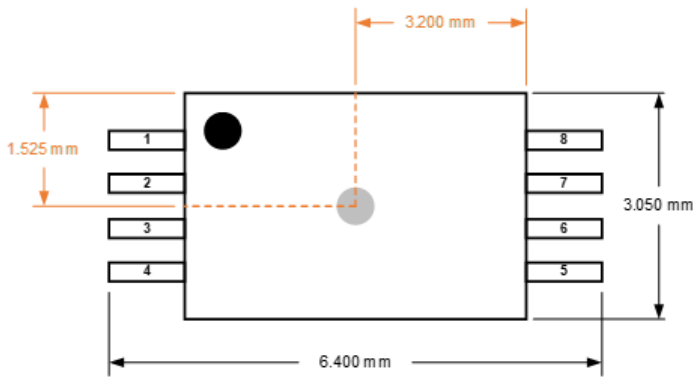

Figure 15: XtremeSense TMR Sensor Location in x-y Plane for CT310 in TSSOP-8 Package

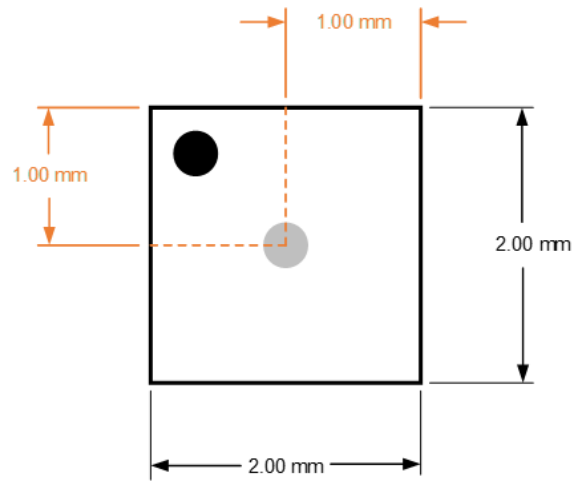

Figure 16: XtremeSense TMR Sensor Location in x-y Plane for CT310 in DFN-8 Package

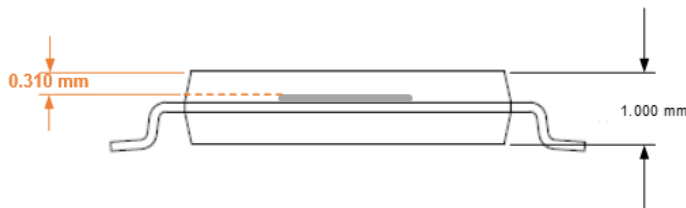

Figure 17: XtremeSense TMR Sensor Location in z Dimension for CT310 in TSSOP-8 Package

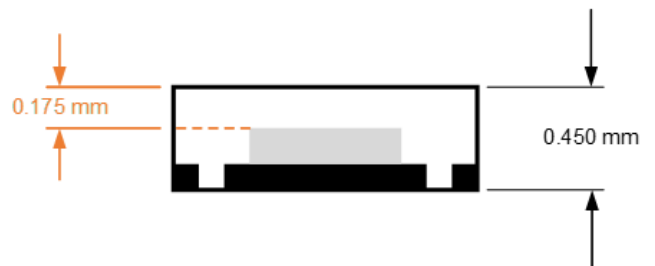

Figure 18: XtremeSense TMR Sensor Location in z Dimension for CT310 in DFN-8 Package

PACKAGE OUTLINE DRAWINGS

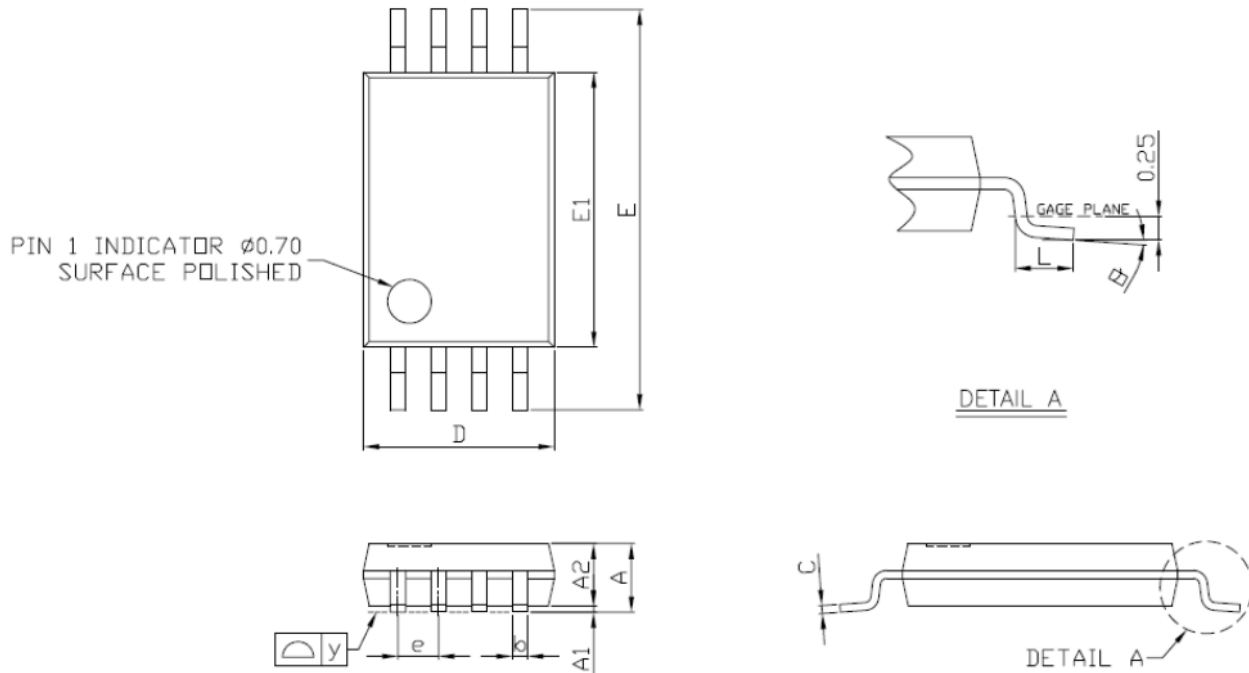
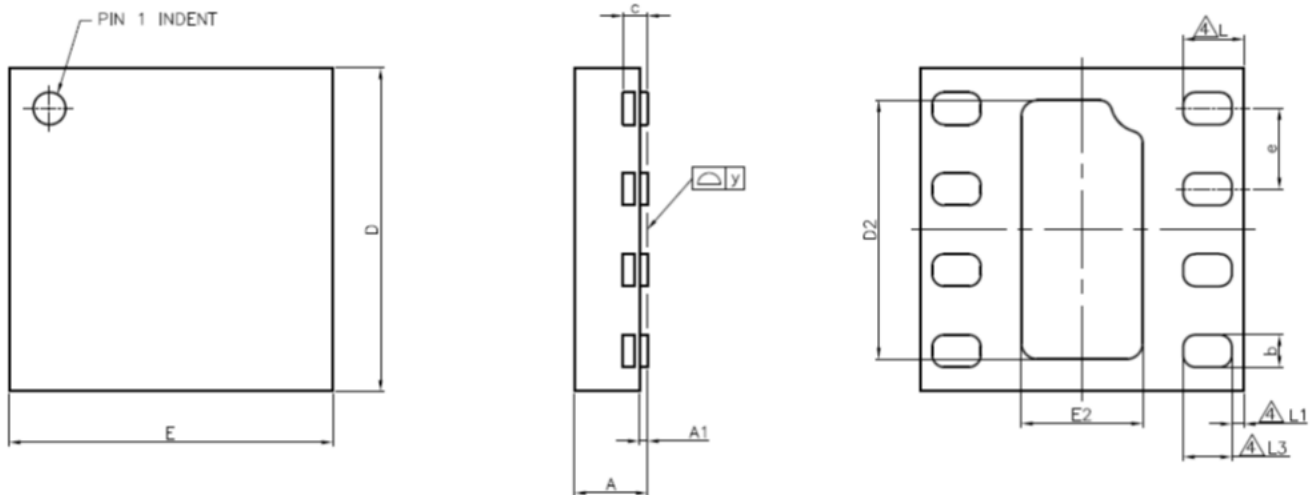

Figure 19: TSSOP-8 Package Drawing

Table 2: CT310 TSSOP-8 Package Dimensions

Symbol	Dimensions in Millimeters (mm)		
	Min.	Typ.	Max.
A	1.05	1.10	1.20
A1	0.05	0.10	0.15
A2	–	1.00	1.05
b	0.25	–	0.30
C	–	0.127	–
D	2.90	3.05	3.10
E	6.20	6.40	6.60
E1	4.30	4.40	4.50
e	–	0.65	–
L	0.50	0.60	0.70
y	–	–	0.076
θ	0°	4°	8°



NOTES:

1. The terminal #1 identifier is a laser marked feature.

Figure 20: DFN-8 Package Drawing

Table 3: CT310 DFN-8 Package Dimensions

Symbol	Dimensions in Millimeters (mm)		
	Min.	Typ.	Max.
A	0.40	0.45	0.50
A1	0.00	0.02	0.05
b	0.15	0.20	0.25
c	–	0.150 REF	–
D	1.925	2.000	2.075
D2	1.550	1.600	1.650
E	1.925	2.000	2.075
E2	0.700	0.750	0.800
e	–	0.500	–
L Δ	0.325	0.375	0.425
L1 Δ	–	0.075	–
L3 Δ	0.250	0.300	0.350
y	0.000	–	0.075

TAPE AND REEL POCKET DRAWINGS AND DIMENSIONS

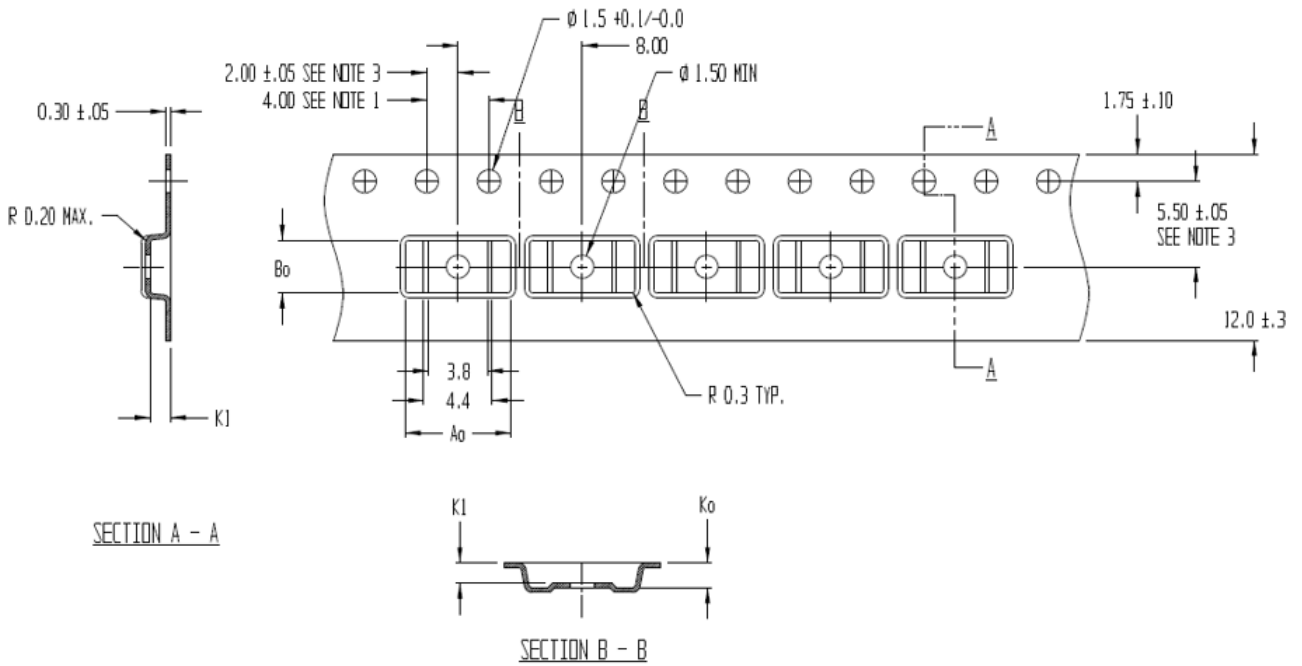

Ao = 6.80
 Bo = 3.40
 Ko = 1.60
 K1 = 1.30

- NOTES:
1. 10 SPROCKET HOLE PITCH CUMULATIVE TOLERANCE ±0.2
 2. CAMBER IN COMPLIANCE WITH EIA 481
 3. POCKET POSITION RELATIVE TO SPROCKET HOLE MEASURED AS TRUE POSITION OF POCKET, NOT POCKET HOLE

Figure 21: TSSOP-8 Tape and Pocket Drawings

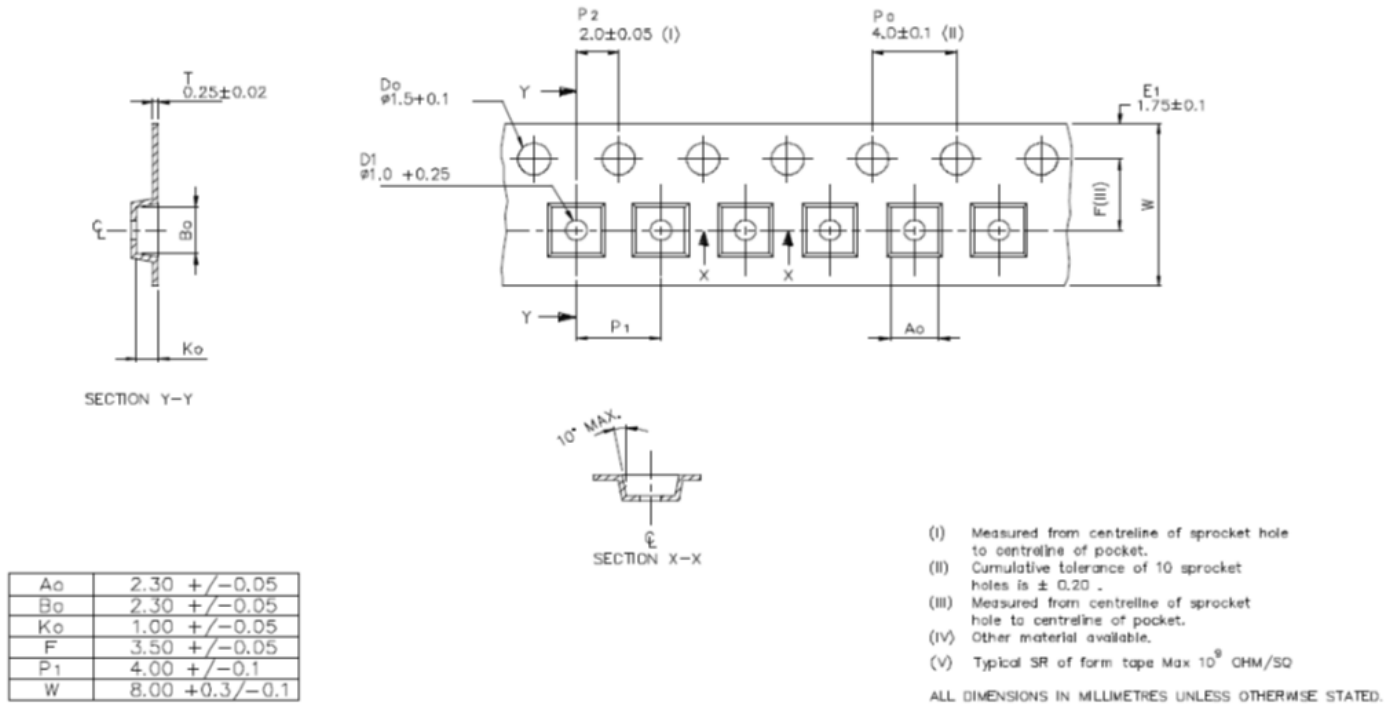

Figure 22: DFN-8 Tape and Pocket Drawings

PACKAGE INFORMATION

Table 4: CT310 Package Information

Part Number	Package Type	# of Leads	Package Quantity	Lead Finish	Eco Plan [1]	MSL Rating [2]	Operating Temperature [3]	Device Marking [4]
CT310LS-IT8	TSSOP	8	3000	Sn	Green & RoHS	1	-40°C to 85°C	CT310LS-IT8 YYWWSS
CT310LS-AT8	TSSOP	8	3000	Sn	Green & RoHS	1	-40°C to 125°C	CT310LS-AT8 YYWWSS
CT310LS-HD8	DFN	8	3000	Sn	Green & RoHS	1	-40°C to 125°C	310H YWWSS

[1] RoHS is defined as semiconductor products that are compliant to the current EU RoHS requirements. It also will meet the requirement that RoHS substances do not exceed 0.1% by weight in homogeneous materials. Green is defined as the content of chlorine (Cl), bromine (Br), and antimony trioxide based flame retardants satisfy JS709B low halogen requirements of $\leq 1,000$ ppm.

[2] MSL Rating = Moisture Sensitivity Level Rating as defined by JEDEC standard classifications.

[3] Package will withstand ambient temperature range of -40°C to 150°C and storage temperature range of -65°C to 165°C.

[4] Device Marking for TSSOP is defined as CT310LS-XT8 YYWWSS where CT310LS = base part number, X = temperature code, T8 = TSSOP-8 package, YY = year, WW = work week, and SS = sequential number. DFN is defined as 300X where X = temperature code and Y = year, WW = work week, and S = sequential number.

Revision History

Number	Date	Description
1	April 24, 2024	Document rebranded and minor editorial updates

Copyright 2024, Allegro MicroSystems.

Allegro MicroSystems reserves the right to make, from time to time, such departures from the detail specifications as may be required to permit improvements in the performance, reliability, or manufacturability of its products. Before placing an order, the user is cautioned to verify that the information being relied upon is current.

Allegro's products are not to be used in any devices or systems, including but not limited to life support devices or systems, in which a failure of Allegro's product can reasonably be expected to cause bodily harm.

The information included herein is believed to be accurate and reliable. However, Allegro MicroSystems assumes no responsibility for its use; nor for any infringement of patents or other rights of third parties which may result from its use.

Copies of this document are considered uncontrolled documents.

For the latest version of this document, visit our website:

www.allegromicro.com