

Allegro Part Numbering Guide

This document provides a guide to the part numbering codes used by Allegro™ MicroSystems for general sales customer orders. Current individual datasheets for specific parts should be consulted before ordering. This guide should be used for reference only and is not intended to be a complete source and may be superseded by subsequent procedures. Individual part numbers may deviate from the specifications in this document. All possible combinations of device type, operating temperature range, and package style are not necessarily available.

Table of Contents

Complete Part Numbers	2
Operating Temperature Ranges	4
Package Designators	5
Instructions (Finishing)	6

Complete Part Numbers

Complete Part Number Format

("A" initial character style, general product lines)

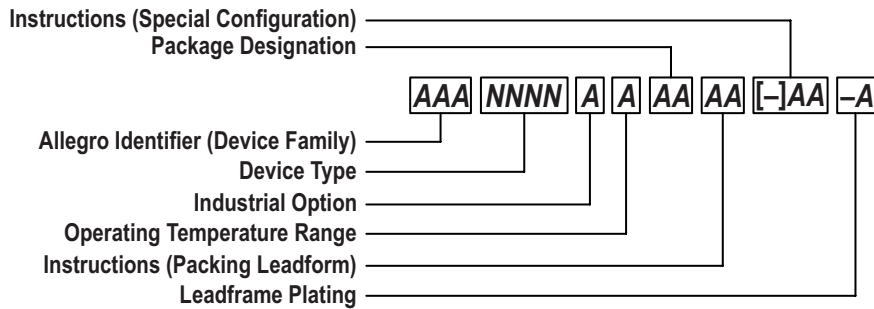

Allegro Identifier	[A, and optional 1 to 2 letters]
Device Type	[3 to 4 numbers] functional type
Industrial Option	[optional 1 letter] blank indicates default configuration; N: industrial
Operating Temperature Range	[1 letter] ambient temperature range
Package Designation	[1 or 2 letters] body configuration
Instructions (Finishing)	Leadform/packing option, etc. Blank indicates default configuration
Leadframe Plating	["-" and 1 letter] nonlead (Pb-free) option

Complete Part Number Format

("A" initial character style, for all part numbers with 5-digit device type)

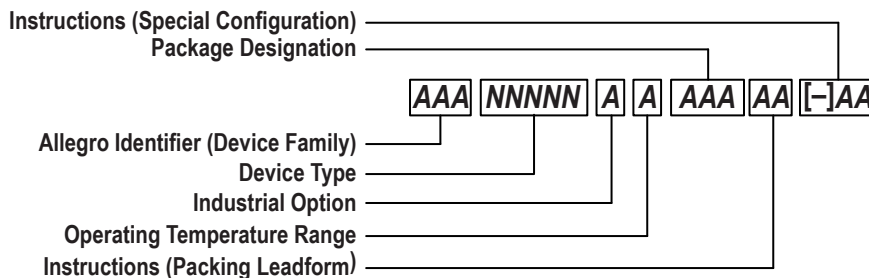

Allegro Identifier	[A, and optional 1 to 2 letters]
Device Type	[5 numbers] functional type
Industrial Option	[optional 1 letter] blank indicates default configuration; N: industrial
Operating Temperature Range	[1 letter] ambient temperature range
Package Designation	[3 letters] body configuration
Instructions (Finishing)	Leadform/packing option, etc. Blank indicates default configuration

Complete Part Numbers (continued)

Complete Part Number Format (Sensed current range style, current sensor IC product lines)

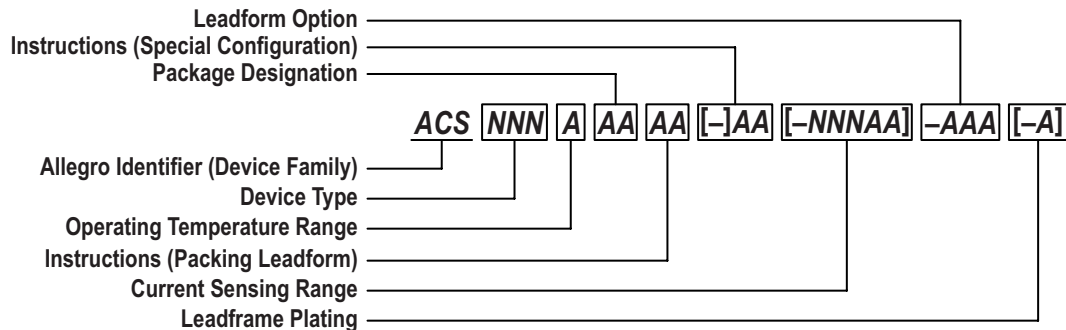

Allegro Identifier	ACS
Device Type	[3 numbers] functional type
Operating Temperature Range	[1 letter] ambient temperature range
Package Designation	[1 or 2 letters] body configuration
Instructions (Finishing)	Leadform/packing option, etc. Blank indicates default configuration
Current Sensing Range	[3 numbers] optimal sensing amperage range [1 letter] measurable sensing range multiplier. A: 1 × optimal, B: 2 × optimal, C: 3 × optimal [1 letter] current direction measurable. B: bidirectional, U: unidirectional
Leadform (75x series)	[3 letters] PFF: formed signal leads, formed current terminals, PSF: formed signal leads, straight current terminals, PSS: straight signal leads, straight current terminals
Leadframe Plating	["-" and 1 letter] nonlead (Pb-free) option

Complete Part Number Format ("U" initial character style, general product lines)

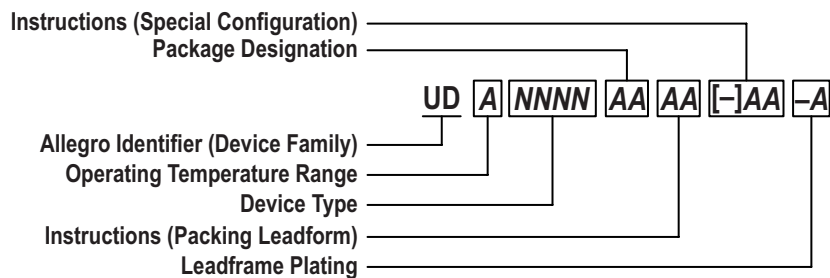

Allegro Identifier	UD
Operating Temperature Range	[1 letter] ambient temperature range
Device Type	[3 to 4 numbers] functional type
Package Designation	[1 or 2 letters] body configuration
Instructions (Finishing)	Leadform/packing option, etc. Blank indicates default configuration
Leadframe Plating	["-" and 1 letter] nonlead (Pb-free) option

Operating Temperature Ranges

Complete Part Number Format ("A" initial character style, general product lines)

Part Number Token	Descriptor	Operating Ambient Temperature Range
A	Commercial A	-10°C to 60°C
B	Extended Commercial B	-25°C to 75°C
C	Commercial C	0°C to 70°C
D	Commercial D	0°C to 50°C
E	Extended Automotive/Industrial E	-40°C to 85°C
F	Extended Automotive/Industrial F	-40°C to 95°C
G	Extended Industrial	-40°C to 105°C
K	Extended Industrial	-40°C to 125°C -40°C to 135°C -40°C to 150°C, when $T_J(\text{max}) \leq 150^\circ\text{C}$
L	Automotive	-40°C to 150°C
M	Extended Commercial M	-20°C to 105°C
P	Extended Automotive/Commercial P	-40°C to 160°C
S	Standard	-20°C to 85°C
X	Custom	Refer to datasheet for custom temperature range

Complete Part Number Format ("U" initial character style, general product lines)

Part Number Token	Descriptor	Operating Ambient Temperature Range
K	Extended Automotive/Industrial	-40°C to 125°C (typical)
N	Commercial/Industrial	-20°C to 85°C (typical)
Q	Automotive/Industrial	-40°C to 85°C (typical)

Package Designators

A – Dual in-line (MS-001, MS-010, MS-011)
CA – Current sensor device
CB – Current sensor device
CG – Chip scale device
CW – Unscribed wafer
EC – Square leadless (exposed pad) 0.40 mm contact pitch, quad very-very-thin chip carrier (MO-220)
EE – Square leadless (exposed pad) 0.50 mm contact pitch, dual ultra-thin chip carrier (MO-229)
EG – Rectangular leadless (exposed pad) 0.50 mm pitch, quad very-very-thin chip carrier (MO-220)
EH – Rectangular leadless (exposed pad) 0.50 mm pitch, dual very-very-thin chip carrier (MO-229)
EJ – Square leadless (exposed pad) 0.50 mm pitch, dual very-very-thin chip carrier (MO-229)
EK – Square leadless (exposed pad) 0.95 mm pitch, dual very-very-thin chip carrier (MO-229)
ES – Square leadless (exposed pad) 0.50 mm contact pitch, quad very-very-thin chip carrier (MO-220)
ET – Square leadless (exposed pad) 0.50 mm contact pitch, quad very-thin chip carrier (MO-220)
EU – Square leadless (exposed pad) 0.65 mm contact pitch, quad very-very-thin chip carrier (MO-220)
EV – Square leadless (exposed pad) 0.50 mm contact pitch, quad very-thin chip carrier (MO-220)
EW – Rect. leadless (exposed pad) 0.50 mm contact pitch, dual super-thin chip carrier (MO-229)
EX – Square leadless (exposed current loop) 0.50 mm contact pitch, quad very-very-thin chip carrier (MO-220)
JP – Low-profile QFP (exposed pad) (MS-026)
JS – Thin-profile QFP (exposed pad) (MS-026)
K – Mini-SIP, four leads
KA – Mini-SIP, five leads
KB – Mini-SIP, three leads
KC – Mini-SIP, three leads
KE – Mini-SIP, four leads
KH – Mini-SIP, three leads
KN – Mini-SIP, four leads
KT – Mini-SIP, four leads
L – Narrow-body SOIC (MS-012)
LA – Wide-body SOIC with internal sensed current path (MS-013)
LB – Wide-body SOIC with heat-sink semi-tabs (MS-013)
LC – Current sensor, narrow-body SOIC (MS-012)
LD – TSSOP, 0.50 mm pitch (MO-153)
LE – TSSOP, 0.65 mm pitch (MO-153)
LF – QSOP 0.635 mm pitch
LG – TSSOP with heat-sink semitabs, 0.50 mm pitch
LH – Low-profile, three- or five-terminal surface mount (SOT23W)
LJ – Eight-lead narrow-body SOIC with exposed pad (MS-012)
LK – Narrow-body SOIC with 1 mm pin pitch
LL – SOT, three leads (SOT89/TO-243AA) prior to trimming
LN – Narrow-body SSOP with 1 mm pin pitch
LP – TSSOP (exposed pad), 0.65 mm pitch (MO-153)
LQ – QSOP, 0.80 mm pitch
LR – Current sensor device
LS – Current sensor device
LT – SOT, three leads (SOT89/TO-243AA)
LU – TSSOP, 0.65 mm pitch (MO-153AA), 8 leads
LV – TSSOP (exposed pad), 0.50 mm pitch, 38 leads
LW – Wide-body SOIC (MS-013)
LY – Narrow-body TSSOP (exposed pad), 0.50 mm pitch
MA – Wide-body SOIC with internal sensed current path (MS-013)
OL – SOIC, 1.27 mm pitch, 8 leads
SE – SIP, 4 leads, sensor Hall device combined in overmolded case
SG – SIP, 4 leads, sensor Hall device combined in overmolded case
SH – SIP, 4 leads, sensor Hall device combined in overmolded case
SJ – SIP, 4 leads, sensor Hall device combined in overmolded case
SL – SIP, 3 leads, sensor Hall device combined in overmolded case
SM – SIP, 3 leads, sensor device combined in overmolded case
SN – SIP, 3 leads, sensor device combined in overmolded case
SP – SIP, 3 leads, sensor Hall device combined in overmolded case
UA – Three-lead, thin mini-SIP
UB – Two-lead, thin mini-SIP
UC – Three-lead, thin mini-SIP
UD – Sensor device with 1 passive component
UE – Two-lead, thin mini-SIP, sensor Hall device with recessed tie bar burr area at top of package
UF – Three-lead, thin mini-SIP
UG – Three-lead, thin mini-SIP

Note: Two character package designators shown; some part numbering variations use three character package designations (not shown).

Instructions (Finishing)

Packing/Leadform

Suffix	Media Type	Definition
BU	Bulk Bag	
BU	Bulk Tube	
BU	Bulk Tray	
BU	Bulk Container	
BU	Bulk Dry Box	
BX	Bulk Bag	Full Outer Box Qty. No Partial.
FF	Tube	Variable Order Increment Quantities
FS	Tube	Variable Order Increment Quantities
LC	Bulk Bag	100 mm Lead Form, Full Outer Box Qty. Order Increment
LF	Bulk Bag	Lead Form per Customer Drawing, Full Outer Box Qty. Order Increment
LI	14" Tape and Reel	Special Instructions per CAS
LN	13" Tape and Reel	Special Instructions per CAS
LT	7" Tape and Reel	6k Order Increment
LU	7" Tape and Reel	Samples Only
LU	13" Tape and Reel	Samples Only
LX	13" Tape and Reel	Full Outer Box Qty. Order Increment - No Partial
MB	Bulk Bag	Magnetized Mechanical Samples
PT	Tray	Full Outer Box Qty. Order Increment
PX	Tray	Full Outer Box Qty. No Partial.
SR	13" Tape and Reel	Single Reel Order Increment
SS	Tube	Variable order increment quantities
TA	14" Tape and Reel	Radial - Style A
TC	14" Tape and Reel	Radial - Style C
TD	7" Tape and Reel	Samples Only - Qty by Special Instructions
TF	13" Tape and Reel	Lead Form per Customer Specification, Full Box Qty.

Suffix	Media Type	Definition
TG	13" Tape and Reel	Lead Form per Customer Specification, Full Box Qty.
TH	13" Tape and Reel	Lead Form per Customer Specification, Full Box Qty.
TI	14" Tape and Reel	Straight Leads
TJ	13" Tape and Reel	Lead Form, Full Outer Box Qty. Order Increment
TK	7" Tape and Reel	Single Reel Order Increment
TK	13" Tape and Reel	Single Reel Order Increment
TK	13" Tape and Reel	Full Outer Box Qty. Order Increment
TL	Bulk Bag	Horizontal Mount Leadform, Full Box Qty. Order Increment
TN	13" Tape and Reel	Production Only - No Lead Form, Full Outer Box Qty. Order Increment
TN	13" Tape and Reel	Samples Only - Single Reel Order Increment
TP	Ammo Pack	Lead Form Radial - Style P
TQ	Ammo Pack	Straight Lead Radial - Style Q
TR	7" Tape and Reel	Variable Order Increment Quantities
TR	13" Tape and Reel	Variable Order Increment Quantities
TR	13" Tape and Reel	Full Outer Box Qty. Order Increment
TR	7" Tape and Reel	Full Outer Box Qty. Order Increment
TS	13" Tape and Reel	Horizontal Mount Leadform, Full Box Qty. Order Increment
TV	Tube	Various Lead Forms
TW	13" Tape and Reel	Lead form- Special Label
TX	13" Tape and Reel	Lead Form per Customer Specification, Full Box Qty.
UL	Media per Special Instruction	Tested, Unlocked Samples
XX	Media per Special Instruction	Tested Product (1st Occurrence)
YY	Media per Special Instruction	Tested Product (2nd Occurrence)
ZZ	Media per Special Instruction	Unfinished Product Only (This Suffix may be used for any Package Code and uses an Order Increment and Fixed Lot Multiplier of 1)

Special Configuration

- I1, -I2, -I3 – Two-wire current level
- LN – Low on tooth
- LT – Low on tooth/TPOS
- R – Internal pull-up resistor

Note: Special configurations shown represent a sample of available special configurations.

Leadframe Plating

- B – Tin-Bismuth
- J – Wettable flank
- P – Nickel Palladium-Gold
- R – Sidewall plating
- T – Matte tin

Revision History

Number	Date	Description
1	April 30, 2014	Added UB package
2	August 20, 2014	Added -R and -B designators to Leadframe Plating
3	November 20, 2014	Updated Package Designators list
4	January 21, 2015	Added MA package to Package Designators list
5	February 22, 2016	Updated Complete Part Numbers format
6	August 29, 2016	Added SR package/leadform, -J leadframe plating, and LR package
7	February 8, 2017	Added notes to Package Designators and Special Configuration
8	July 20, 2017	Added LS, SL, SM, SN, and UC packages to Package Designators list
9	September 12, 2018	Added CW, LL, SP, UD, UE, WB; removed ED, EF, M
10	September 19, 2019	Removed EL package designator; other minor editorial updates
11	August 18, 2021	Added industrial-grade option (page 2); added KH designator, removed B and WB designators (page 5); updated packing/leadforms (page 6)
12	January 7, 2022	Corrected SN package from 2 to 3 leads and SL package from 4 to 3 leads; removed Hall-specific reference in SN, SM, and UD packages

Copyright 2022, Allegro MicroSystems.

The information contained in this document does not constitute any representation, warranty, assurance, guaranty, or inducement by Allegro to the customer with respect to the subject matter of this document. The information being provided does not guarantee that a process based on this information will be reliable, or that Allegro has explored all of the possible failure modes. It is the customer's responsibility to do sufficient qualification testing of the final product to ensure that it is reliable and meets all design requirements.

For the latest version of this document, visit our website:

www.allegromicro.com