

DC-to-DC Step-Down Converter

Features and Benefits

- 1.5 A output current supplied in a small power surface mount package
- High efficiency: 81% at $V_{IN}=15\text{ V}$, $I_O=0.5\text{ A}$, $V_O=5\text{ V}$
- Requires only six external components (optional soft start requires an additional capacitor)
- Oscillation circuit built-in (frequency 300 kHz typical)
- Constant current type overcurrent protection circuit and an overheating protection circuit built in
- Soft start function built-in (can be implemented as an ON/OFF function, output OFF state at low level)
- Low consumption current during output OFF state

Package: TO252-5 (SC-63)



Not to scale

Description

The SI-8008TM DC voltage regulator is a DC-to-DC buck convertor that attains an oscillation frequency of 300 kHz, and has an integrated miniaturized choke coil, allowing it to serve as a small, high efficiency power supply in a compact TO252-5 (SC-63) package.

The switching regulator function realizes a high efficiency switching regulator operation without adjustment, requiring only six external support components, and an optional capacitor for soft start operation and an optional transistor for on/off control. The SI-8008TM includes overcurrent and overheating protection circuits.

Applications include:

- DVD recorder
- FPD TV
- Telecommunications equipment
- Office automation equipment, such as printers
- On-board local power supply
- Output voltage regulator for second stage of SMPS (switched mode power supply)

Functional Block Diagram with Typical Application

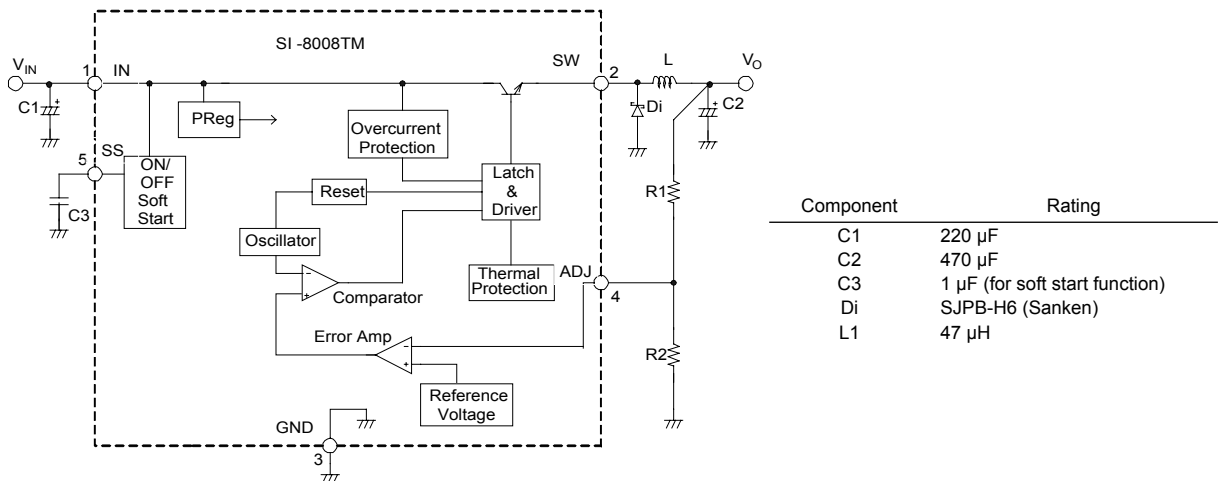

Figure 1. Application implementing soft start, without implementation of on/off control.

Selection Guide

Part Number	Output Voltage (V)	Efficiency (Typical) (%)	Input Voltage (V)	Output Current (A)	Packing
SI-8008TM-TL (Adjustable Type)	0.8 (V_{ADJ})	81 (5 V Set-up)	43	0 to 1.5	3000 pieces per reel

Absolute Maximum Ratings

Characteristic	Symbol	Remarks	Rating	Units
DC Input Voltage	V_{IN}		43	V
Power Dissipation 1	P_{D1}	Glass-epoxy board mounting in 900 mm ² , copper area 4.3%, $T_J \leq 125^\circ\text{C}$	1.06	W
Power Dissipation 2	P_{D2}	Glass-epoxy board mounting in 900 mm ² , copper area 50% $T_J \leq 125^\circ\text{C}$	1.65	W
Junction Temperature	T_J	The thermal protection circuit is built-in and may enable when junction temperature rises to 130°C or higher. Recommended maximum junction temperature during product operation is 125°C.	-30 to 150	°C
Storage Temperature	T_{stg}		-40 to 150	°C
Thermal Resistance (Junction-case)	$R_{\theta j-c}$		6	°C/W
Thermal Resistance (Junction-ambient air)	$R_{\theta j-a}$	Glass-epoxy board mounting in 900 mm ² , copper area 4.3%	95	°C/W

Recommended Operating Conditions

Characteristic	Symbol	Remarks	Min.	Max.	Units
DC Input Voltage Range ¹	V_{IN}	$I_O = 0$ to 1.5 A	$V_O + 3$	40	V
DC Output Voltage Range	V_O		0.8	24	V
DC Output Current Range ²	I_O	$V_{IN} \geq V_O + 3$ V	0	1.5	A
Operating Junction Temperature Range	T_{JOP}		-20	100	°C
Operating Temperature Range ²	T_{OP}		-20	85	°C

¹The minimum value of the input voltage, $V_{IN}(\text{min})$ is the larger of either 4.5 V or $V_O + 3$ V. In the case in which V_{IN} is in the range $V_O + 2$ V to $V_O + 3$ V, $V_{IN}(\text{min})$ is set so that $I_O = 1$ A (maximum).

²To be used within the allowable package power dissipation characteristics (refer to Power Dissipation chart).

All performance characteristics given are typical values for circuit or system baseline design only and are at the nominal operating voltage and an ambient temperature, T_A , of 25°C, unless otherwise stated.

ELECTRICAL CHARACTERISTICS, valid at $T_A = 25^\circ\text{C}$, $V_O = 5\text{ V}$ (adjusted), $R_1 = 4.2\text{ k}\Omega$, $R_2 = 0.8\text{ k}\Omega$

Characteristic	Symbol	Test Conditions	Min.	Typ.	Max.	Units
Reference Voltage	V_{ADJ}	$V_{IN} = 15\text{ V}$, $I_O = 0.1\text{ A}$	0.784	0.8	0.816	V
Reference Voltage Temperature Coefficient	$\Delta V_{REF}/\Delta T$	$V_{IN} = 15\text{ V}$, $I_O = 0.1\text{ A}$, $T_{OP} = 0\text{ to }100^\circ\text{C}$	–	± 0.1	–	mV/ $^\circ\text{C}$
Efficiency*	η	$V_{IN} = 15\text{ V}$, $I_O = 0.5\text{ A}$	–	81	–	%
Operating Frequency	f_O	$V_{IN} = 15\text{ V}$, $I_O = 0.5\text{ A}$	–	300	–	kHz
Line Regulation	V_{Line}	$V_{IN} = 10\text{ to }30\text{ V}$, $I_O = 0.5\text{ A}$	–	60	80	mV
Load Regulation	V_{Load}	$V_{IN} = 15\text{ V}$, $I_O = 0.2\text{ to }1.5\text{ A}$	–	10	40	mV
Overcurrent Protection Threshold Current	I_S	$V_{IN} = 15\text{ V}$	1.6	–	–	A
SS Terminal On/Off Operation Threshold Voltage	V_{SSL}		–	–	0.5	V
SS Terminal On/Off Operation Outflow Current	I_{SSL}	$V_{SSL} = 0\text{ V}$	–	10	40	μA
Quiescent Current 1	I_q	$V_{IN} = 15\text{ V}$, $I_O = 0\text{ A}$	–	6	–	mA
Quiescent Current 2	$I_{q(off)}$	$V_{IN} = 15\text{ V}$, $V_{SS} = 0\text{ V}$	–	200	400	μA

*Efficiency is calculated by the following equation.

$$\eta (\%) = \frac{V_O \times I_O}{V_{IN} \times I_{IN}} \times 100$$

Pin-out Diagram

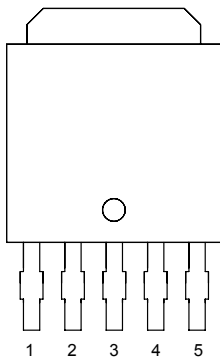

Terminal List Table

Name	Number	Function
IN	1	Supply voltage
SW	2	Regulated supply output
GND	3	Ground terminal
ADJ	4	Terminal for resistor bridge feedback
SS	5	<p>The SS terminal is used to enable soft start and to control on/off operation of the IC output, V_O (see figure 2). To enable soft start, connect a capacitor between SS and ground. To control on/off operation, connect an NPN bipolar transistor, in a TTL open collector output configuration, between the SS terminal and GND. Turn off is done by decreasing V_{SSL} below its rated level.</p> <p>When both soft start and V_O on/off are used, a protection measure such as current limiting is required because, if the capacitance of C3 large, the discharge current of C3 flows across the transistor for on/off operation. Because a pull-up type resistor is provided inside the IC, no external voltage can be applied.</p>

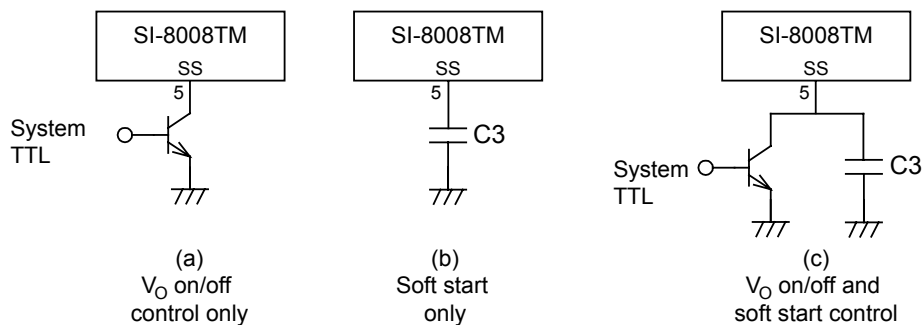
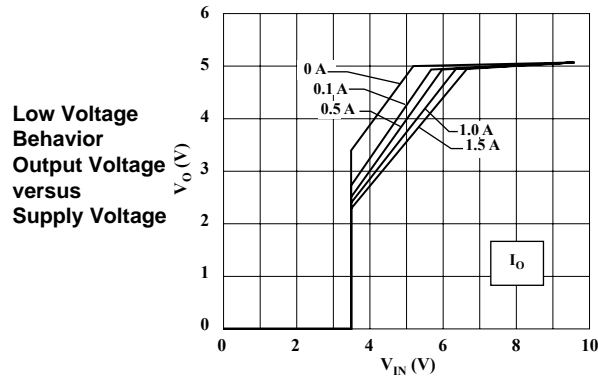
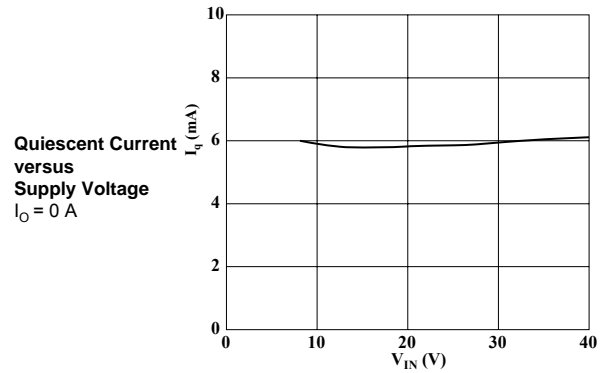
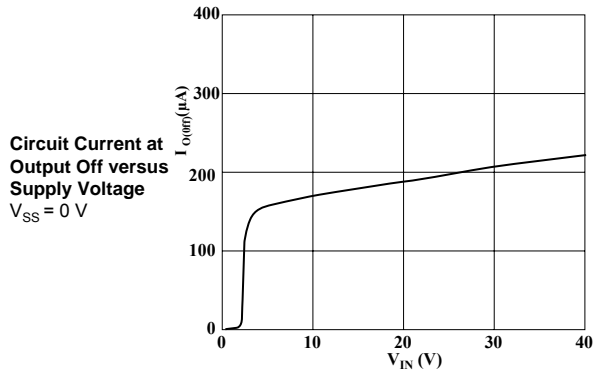
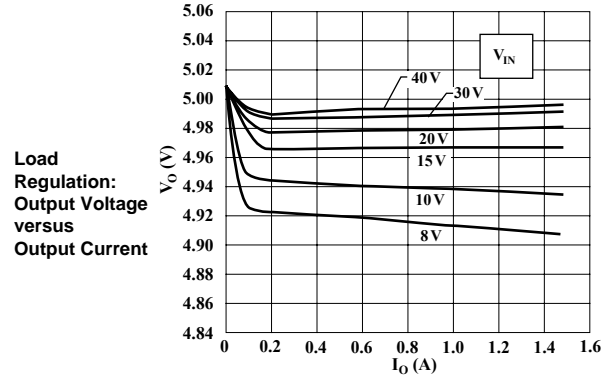
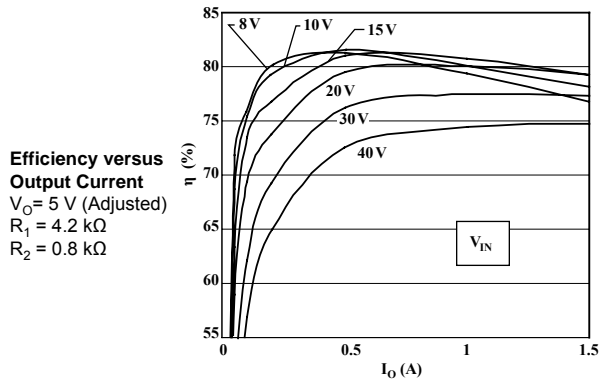

Figure 2. Alternative configurations for SS pin. If neither soft start nor V_O on/off is required, the SS pin is left open.

SI-8008TM Performance Characteristics at $T_A = 25^\circ\text{C}$



SI-8008TM Thermal Performance Characteristics

Thermal Protection: Output Voltage versus Junction Temperature

$V_{IN} = 8\text{ V}$, $I_O = 0.01\text{ A}$

Junction temperature, T_J , can be calculated as:

$$T_J = P_D \times R_{\theta JC} + T_C$$

where $R_{\theta JC} = 6^\circ\text{C/W}$, and T_C is the temperature taken by a thermocouple mounted adjacent to the case on the tab at the location indicated:

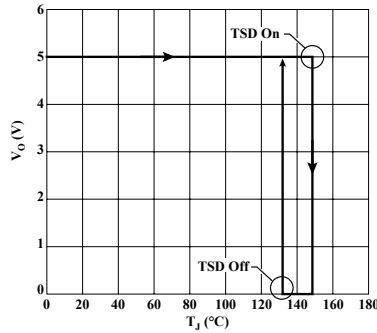
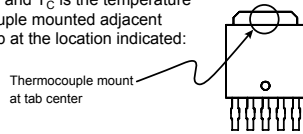

Power Dissipation versus Ambient Temperature

$T_J(\text{max}) = 125^\circ\text{C}$

Mounted on glass-epoxy PCB (30 mm × 30 mm), with varying exposed copper areas

$$P_D = V_O \cdot I_O \left(\frac{100}{\eta_x} - 1 \right) - V_F \cdot I_O \left(1 - \frac{V_O}{V_{IN}} \right)$$

where:

V_O is output voltage in V,
 V_{IN} is input supply voltage in V,
 I_O is output current in A,
 η_x is IC efficiency in percent (varies with V_{IN} and I_O ; refer to efficiency curve for value), and
 V_F is forward voltage for the input diode, D_i . In these tests, the Sanken SJPB-H6 was used, at 0.5 V and $I_O = 1.5\text{ A}$.
 For application design, obtain thermal data from the datasheet for the diode.

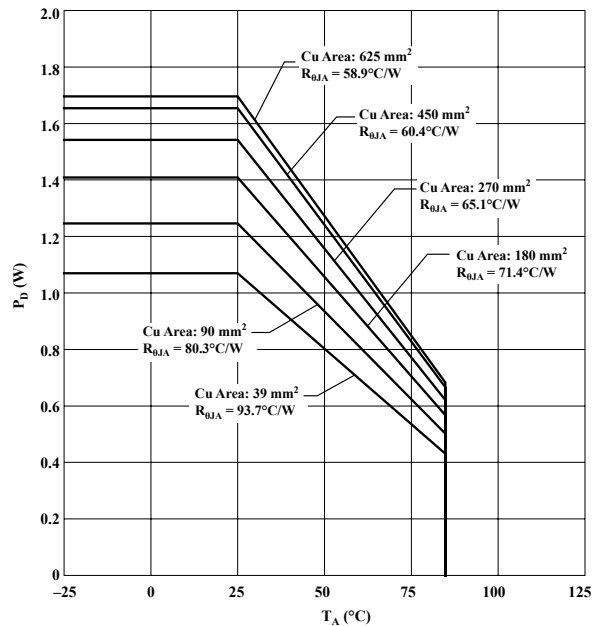

Device Thermal Resistance versus Exposed Copper Area on PCB

Glass-epoxy PCB, 30 mm²

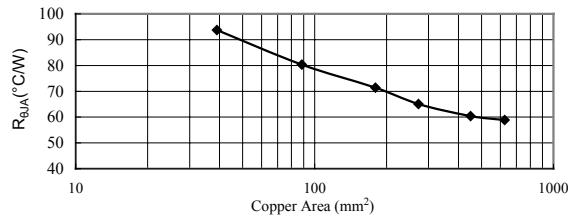

Device Power Dissipation versus Exposed Copper Area on PCB

Glass-epoxy PCB, 30 mm²

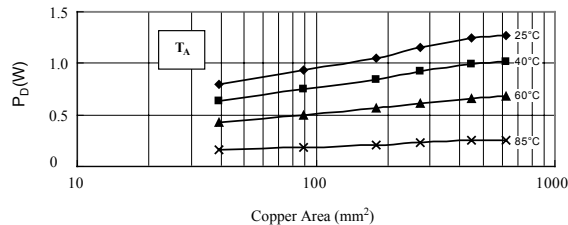

Component Selection

Diode Di

A Schottky-barrier diode must be used for Di. If other diode types are used, such as fast recovery diodes, the IC may be destroyed because of the reverse voltage applied by the recovery voltage or ON voltage.

Choke Coil L1

If the winding resistance of the choke coil is too high, the efficiency may go down to the extent that it is out of the rating. Because the overcurrent protection start current is approximately 2.5 A, attention must be paid to the heating of the choke coil by the magnetic saturation due to overload or short-circuited load.

Capacitor C1, C2, and C3

As large ripple currents flow across C1 and C2, capacitors with high frequency and low impedance for SMPS must be used. Especially when the impedance of C2 is high, the switching waveform may not be normal at low temperature. Please use

neither OS capacitors nor tantalum capacitors which cause an abnormal oscillation for C2.

C3 is a capacitor for soft start. In case soft start function is not used, please keep the SS terminal open. A pull-up resistor is provided inside the IC.

Resistor R1 and R2

R1, R2 is a resistor bridge to the output voltage. I_{ADJ} should be set to 1 mA. To do so, calculate R1, R2 by the following expressions:

$$R1 = \frac{(V_O - V_{ADJ})}{I_{ADJ}} = \frac{(V_O - 0.8)}{1 \times 10^{-3}} (\Omega), R2 = \frac{V_{ADJ}}{I_{ADJ}} = \frac{0.8}{1 \times 10^{-3}} = 0.8k(\Omega)$$

R2 should always be connected for stable operation, even if output voltage, V_O , is set to 0.8 V. It is recommended that V_O be set at $V_{IN} + 8\%$ or greater.

Typical Application Circuit

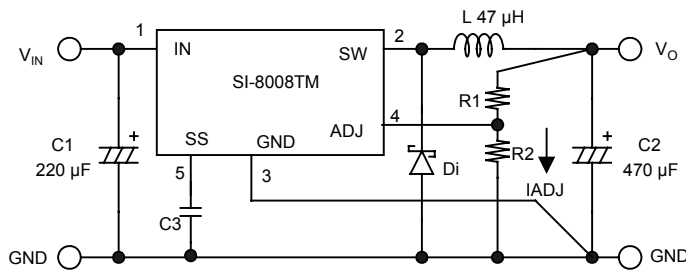

Component	Rating
C1	220 µF
C2	470 µF
C3	1 µF (for soft start function)
Di	SJPB-H6 (Sanken)
L1	47 µH

Recommended PCB Layout

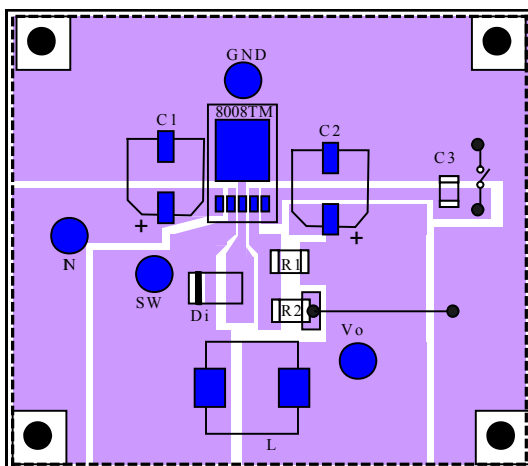

All external components should be mounted as close as possible to the SI-8008TM. The ground of all components should be connected at one point.

Recommended Solder Pad Layout

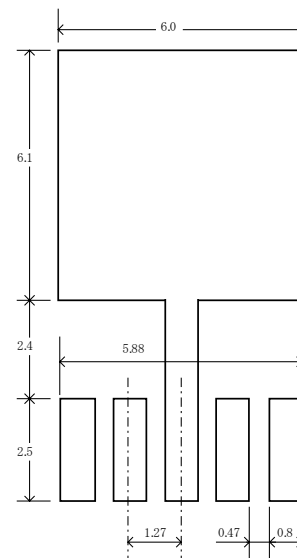

PACKAGE OUTLINE DRAWING, TO252-5

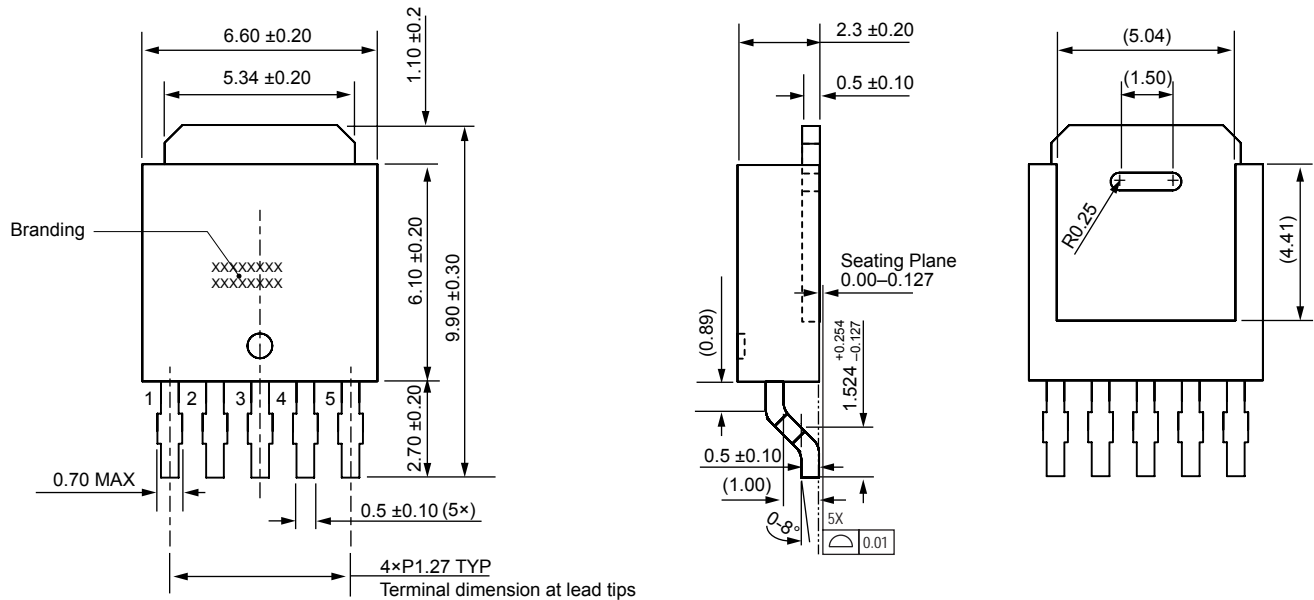

Terminal core material: Cu
 Terminal treatment: Ni plating and solder dip
 Heat sink core material: Cu
 Heat sink treatment: Ni plating
 Approximate weight: 0.33 g

Dimensions in millimeters

Branding codes (exact appearance at manufacturer discretion):
 1st line, type: 8008TM
 2nd line, lot: YM W
 Where: Y is the last digit of the year of manufacture
 M is the month (1 to 9, O, N, D)
 W is the week
 3rd line, Tracking number (four digits)



Device is lead (Pb) free.

PACKING SPECIFICATION

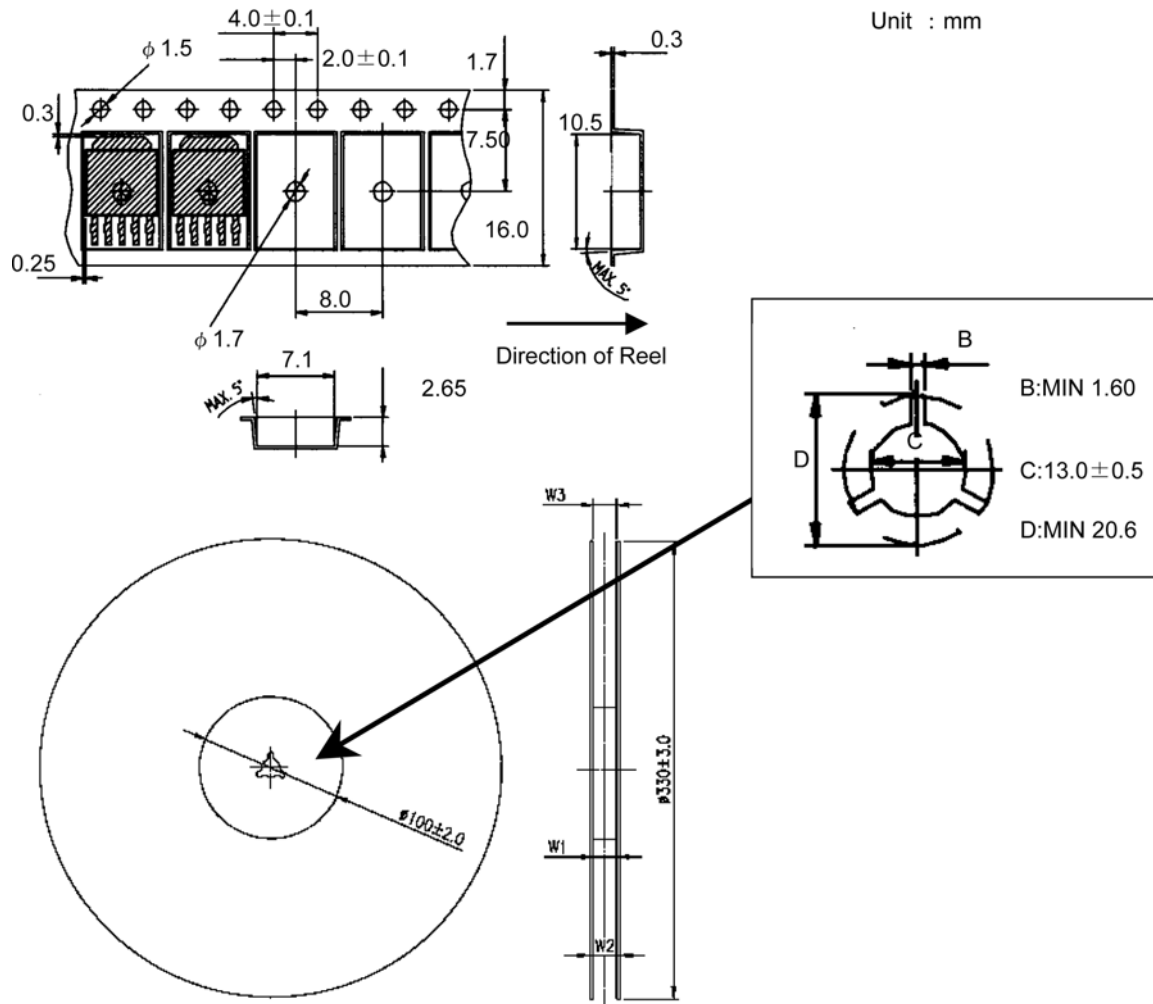

+2		+3
W1	W2 MAX	W3
-0		-0.5
16.4 mm	22.4 mm	16.4 mm

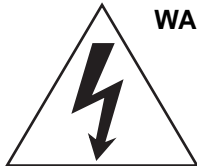

WARNING — These devices are designed to be operated at lethal voltages and energy levels. Circuit designs that embody these components must conform with applicable safety requirements. Precautions must be taken to prevent accidental contact with power-line potentials. Do not connect grounded test equipment.

The use of an isolation transformer is recommended during circuit development and breadboarding.

Because reliability can be affected adversely by improper storage environments and handling methods, please observe the following cautions.

Cautions for Storage

- Ensure that storage conditions comply with the standard temperature (5°C to 35°C) and the standard relative humidity (around 40 to 75%); avoid storage locations that experience extreme changes in temperature or humidity.
- Avoid locations where dust or harmful gases are present and avoid direct sunlight.
- Reinspect for rust on leads and solderability of products that have been stored for a long time.

Cautions for Testing and Handling

When tests are carried out during inspection testing and other standard test periods, protect the products from power surges from the testing device, shorts between adjacent products, and shorts to the heatsink.

Soldering

- When soldering the products, please be sure to minimize the working time, within the following limits:
260±5°C 10 s
350±5°C 3 s
- Soldering iron should be at a distance of at least 1.5 mm from the body of the products

Electrostatic Discharge

- When handling the products, operator must be grounded. Grounded wrist straps worn should have at least 1 MΩ of resistance to ground to prevent shock hazard.
- Workbenches where the products are handled should be grounded and be provided with conductive table and floor mats.
- When using measuring equipment such as a curve tracer, the equipment should be grounded.
- When soldering the products, the head of soldering irons or the solder bath must be grounded in order to prevent leak voltages generated by them from being applied to the products.
- The products should always be stored and transported in our shipping containers or conductive containers, or be wrapped in aluminum foil.

The products described herein are manufactured in Japan by Sanken Electric Co., Ltd. for sale by Allegro MicroSystems, Inc.

Sanken and Allegro reserve the right to make, from time to time, such departures from the detail specifications as may be required to permit improvements in the performance, reliability, or manufacturability of its products. Therefore, the user is cautioned to verify that the information in this publication is current before placing any order.

When using the products described herein, the applicability and suitability of such products for the intended purpose shall be reviewed at the users responsibility.

Although Sanken undertakes to enhance the quality and reliability of its products, the occurrence of failure and defect of semiconductor products at a certain rate is inevitable.

Users of Sanken products are requested to take, at their own risk, preventative measures including safety design of the equipment or systems against any possible injury, death, fires or damages to society due to device failure or malfunction.

Sanken products listed in this publication are designed and intended for use as components in general-purpose electronic equipment or apparatus (home appliances, office equipment, telecommunication equipment, measuring equipment, etc.). Their use in any application requiring radiation hardness assurance (e.g., aerospace equipment) is not supported.

When considering the use of Sanken products in applications where higher reliability is required (transportation equipment and its control systems or equipment, fire- or burglar-alarm systems, various safety devices, etc.), contact a company sales representative to discuss and obtain written confirmation of your specifications.

The use of Sanken products without the written consent of Sanken in applications where extremely high reliability is required (aerospace equipment, nuclear power-control stations, life-support systems, etc.) is strictly prohibited.

The information included herein is believed to be accurate and reliable. Application and operation examples described in this publication are given for reference only and Sanken and Allegro assume no responsibility for any infringement of industrial property rights, intellectual property rights, or any other rights of Sanken or Allegro or any third party that may result from its use.