

Leadscrew Drives

Leadscrews convert rotary motion to linear motion and come in a wide variety of configurations. Screws are available with different lengths, diameters, and thread pitches. Nuts range from the simple plastic variety to precision ground versions with recirculating ball bearings that can achieve very high accuracy.

The combination of microstepping and a quality leadscrew provides exceptional positioning resolution for many applications. A typical 10-pitch (10 threads per inch) screw attached to a 25,000 step/rev. motor provides a linear resolution of 0.000004" (4 millionths, or approximately 0.1 micron) per step.

A flexible coupling should be used between the leadscrew and the motor to provide some damping. The coupling will also prevent excessive motor bearing loading due to any misalignment.

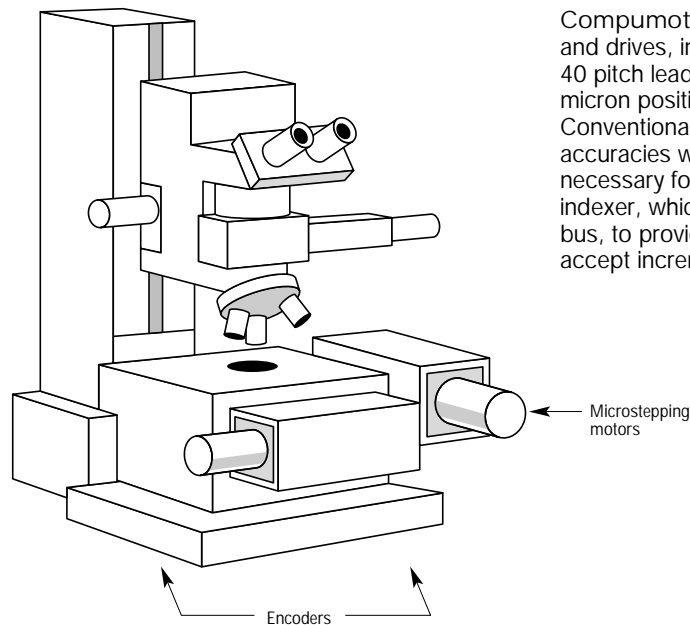

Microscope Positioning

Application Type: X/Y Point to Point

Motion: Linear

Description: A medical research lab needs to automate their visual inspection process. Each specimen has an origin imprinted on the slide with all other positions referenced from that point. The system uses a PC-AT Bus computer to reduce data input from the operator, and determines the next data point based on previous readings. Each data point must be accurate to within 0.1 microns.

Machine Objectives

- Sub-micron positioning
- Specimen to remain still during inspection
- Low-speed smoothness (delicate equipment)
- Use PC-AT Bus computer

Motion Control Requirements

- High resolution, linear encoders
- Stepper (zero speed stability)
- Microstepping
- PC-AT Bus controller

Compumotor Solution: Microstepping motors and drives, in conjunction with a precision ground 40 pitch leadscrew table, provide a means of sub-micron positioning with zero speed stability. Conventional mechanics cannot provide 0.1 micron accuracies without high grade linear encoders. It is necessary for the Compumotor Model AT6400 indexer, which resides directly on the computer bus, to provide full X, Y, Z microscope control and accept incremental encoder feedback.

Precision Grinder

A bearing manufacturer is replacing some equipment that finishes bearing races. The old equipment had a two-stage grinding arrangement where one motor and gearbox provided a rough cut and a second motor with a higher ratio gearbox performed the finishing cut. The designer would like to simplify the mechanics and eliminate one motor. He wants to use a single leadscrew and exploit the wide speed range available with microstepping to perform both cuts. This will be accomplished by moving a cutting tool mounted on the end of the leadscrew into the workpiece at two velocities; an initial velocity for the rough cut and a much reduced final velocity for the finish cut.

The torque required to accelerate the load and overcome the inertia of the load and the rotational inertia of the leadscrew is determined to be 120 oz-in. The torque necessary to overcome friction is measured with a torque wrench and found to be 40 oz-in. A microstepping motor with 290 oz-in of torque is selected and provides adequate torque margin.

This grinder is controlled by a programmable controller (PC) and the environment requires that the electronics withstand a 60°C environment. An indexer will provide the necessary velocities and accelerations. The speed change in the middle of the grinding operation will be signaled to the PC with a limit switch, and the PC will in turn program the new velocity into the indexer. Additionally, the indexer Stall Detect feature will be used in conjunction with an optical encoder mounted on the back of the motor to alert the PC if the mechanics become "stuck."

Other Leadscrew Drive Applications

- XY Plotters
- Facsimile transmission
- Tool bit positioning
- Cut-to-length machinery
- Back gauging
- Microscope drives
- Coil winders
- Slides
- Pick-and-Place machines
- Articulated arms

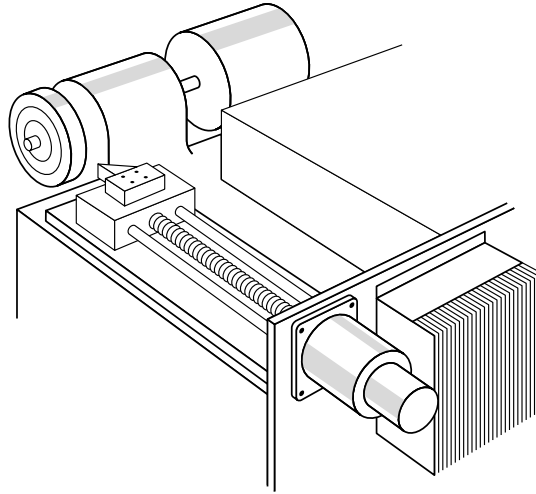

Leadscrew Application Data

Inertia of Leadscrews per Inch

Diameter				Diameter			
In.	Steel	Brass	Alum.	In.	Steel	Brass	Alum.
0.25	0.0017	0.0018	0.0006	2.75	25.1543	26.9510	8.6468
0.50	0.0275	0.0295	0.0094	3.00	35.6259	38.1707	12.2464
0.75	0.1392	0.1491	0.0478	3.25	49.0699	52.5749	16.8678
1.00	0.4398	0.4712	0.1512	3.50	66.0015	70.7159	22.6880
1.25	1.0738	1.1505	0.3691	3.75	86.9774	93.1901	29.8985
1.50	2.2266	2.3857	0.7654	4.00	112.5956	120.6381	38.7047
1.75	4.1251	4.4197	1.4180	4.25	143.4951	153.7448	49.3264
2.00	7.0372	7.5399	2.4190	4.50	180.3564	193.2390	61.9975
2.25	11.2723	12.0774	3.8748	4.75	223.9009	239.8939	76.9659
2.50	17.1807	18.4079	5.9059	5.00	274.8916	294.5267	94.4940

Coefficients of Static Friction Materials (Dry Contact Unless Noted)

	μS
Steel on Steel	0.58
Steel on Steel (lubricated)	0.15
Aluminum on Steel	0.45
Copper on Steel	0.22
Brass on Steel	0.19
Teflon on Steel	0.04

Leadscrew Efficiencies

Type	Efficiency (%)		
	High	Median	Low
Ball-nut	95	90	85
Acme with metal nut*	55	40	35
Acme with plastic nut	85	65	50

* Since metallic nuts usually require a viscous lubricant, the coefficient of friction is both speed and temperature dependent.

System Calculations

Leadscrew Drives

Vertical or Horizontal Application:

ST – Screw type, ball or acme	ST = _____
e – Efficiency of screw	e = _____ %
μ_s – Friction coefficient	μ_s = _____
L – Length of screw	L = _____ inches
D – Diameter of screw	D = _____ inches
p – Pitch	p = _____ threads/inch
W – Weight of load	W = _____ lbs.
F – Breakaway force	F = _____ ounces
Directly coupled to the motor?	yes/no _____
If yes, CT – Coupling type	_____
If no, belt & pulley or gears	_____
Radius of pulley or gear	_____ inches
Gear: Number of teeth – Gear 1	_____
Number of teeth – Gear 2	_____
Weight of pulley or gear	_____ ounces
Weight of belt	_____ ounces

Leadscrew Formulas

The torque required to drive load W using a leadscrew with pitch (p) and efficiency (e) has the following components:

$$T_{\text{Total}} = T_{\text{Friction}} + T_{\text{Acceleration}}$$

$$T_{\text{Friction}} = \frac{F}{2\pi p e}$$

Where:

- F = frictional force in ounces
- p = pitch in revs/in
- e = leadscrew efficiency

$F = \mu_s W$ for horizontal surfaces where μ_s = coefficient of static friction and W is the weight of the load. This friction component is often called "breakaway".

Dynamic Friction: $F = \mu_d W$ is the coefficient to use for friction during a move profile. However, torque calculations for acceleration should use the worst case friction coefficient, μ_s .

$$T_{\text{Accel}} = \frac{1}{g} (J_{\text{Load}} + J_{\text{Leadscrew}} + J_{\text{Motor}}) \frac{\omega}{t}$$

$$\omega = 2\pi p v$$

$$J_{\text{Load}} = \frac{W}{(2\pi p)^2}; J_{\text{Leadscrew}} = \frac{\pi L \rho R^4}{2}$$

Where:

- T = torque, oz-in
- ω = angular velocity, radians/sec
- t = time, seconds
- v = linear velocity, in/sec
- L = length, inches
- R = radius, inches
- ρ = density, ounces/in³
- g = gravity constant, 386 in/sec²

The formula for load inertia converts linear inertia into the rotational equivalent as reflected to the motor shaft by the leadscrew.

Problem

Find the torque required to accelerate a 200-lb steel load sliding on a steel table to 2 inches per second in 100 milliseconds using a 5 thread/inch steel leadscrew 36 inches long and 1.5 inches in

diameter. Assume that the leadscrew has an Acme thread and uses a plastic nut. Motor inertia is given as 6.56 oz-in². In this example, we assume a horizontally oriented leadscrew where the force of gravity is perpendicular to the direction of motion. In non-horizontal orientations, leadscrews will transmit varying degrees of influence from gravity to the motor, depending on the angle of inclination. Compumotor Sizing Software automatically calculates these torques using vector analysis.

1. Calculate the torque required to overcome friction. The coefficient of static friction for steel-to-steel lubricant contact is 0.15. The median value of efficiency for an Acme thread and plastic nut is 0.65. Therefore:

$$F = \mu_s W = 0.15 (200 \text{ lb}) \frac{(16 \text{ oz})}{\text{lb}} = 480 \text{ oz}$$

$$T_{\text{Friction}} = \frac{F}{2\pi p e} = \frac{480 \text{ oz}}{2\pi \times 5 \frac{\text{rev}}{\text{in}} \times 0.65} = 23.51 \text{ oz-in}$$

2. Compute the rotational inertia of the load and the rotational inertia of the leadscrew:

$$J_{\text{Load}} = \frac{W}{(2\pi p)^2} = \frac{200 \text{ lb}}{(2\pi \times 5)^2} \times \frac{16 \text{ oz}}{\text{lb}} = 3.24 \text{ oz-in}^2$$

$$J_{\text{Leadscrew}} = \frac{\pi L \rho R^4}{2} = \frac{\pi (36 \text{ in}) (4.48 \frac{\text{oz}}{\text{in}^3}) (0.75 \text{ in})^4}{2} = 80.16 \text{ oz-in}^2$$

3. The torque required to accelerate the load may now be computed since the motor inertia was given:

$$T_{\text{Accel}} = \frac{1}{g} (J_{\text{Load}} + J_{\text{Leadscrew}} + J_{\text{Motor}}) \frac{\omega}{t}$$

$$\omega = 2\pi \left(\frac{5}{\text{in}}\right) \left(\frac{2 \text{ in}}{\text{sec}}\right) = \frac{20\pi}{\text{sec}}$$

$$= \frac{1}{386 \text{ in/sec}^2} (4.99 + 80.16 + 6.56(\text{oz-in}^2)) \frac{20\pi}{0.1 \text{ sec}}$$

$$= 149 \text{ oz-in}$$

$$T_{\text{Total}} = T_{\text{Friction}} + T_{\text{Accel}}$$

$$T_{\text{Total}} = 23.51 \text{ oz-in} + 149 \text{ oz-in} = 172.51 \text{ oz-in}$$