



MicroSystems, Inc.

Allegro has recently upgraded the following devices: A3250/51, ATS535/6, and ATS635/6, from its older wafer fabrication process to its newer, more efficient wafer process line. Products manufactured on the new equipment have proven to be more robust and, as a result, will require adjustments to the voltage levels on programming boards older than September 01, 2002, in order to program units properly. These adjustments are expected to work for all material regardless of the process. Please refer to preceding application note in order to institute the appropriate adjustments to your programming board.

1. Monitor the +25 V test point with a DVM or oscilloscope and adjust Pot #4 until the test point reads 28 V. This is necessary to create both the new high voltage blow pulse and the program enable pulse. When measuring voltage always reference the GND of the measurement device to the Dut\_GND test point
2. Monitor the DUT Supply test pin with an oscilloscope. Set the scope to trigger on the DUT supply test pin, the trigger level should be set to approximately 2.5 V.
3. With the control software send the program enable sequence and measure the values of  $V_{PH}$ ,  $V_{PL}$ , and  $V_{PP}$ . (See figure 1 below)
  - o The new acceptable values of  $V_{PH}$ ,  $V_{PL}$ , and  $V_{PP}$  are given in table 1 below.

Programming Voltage	Min.	Typ.	Max.	Unit
$V_{PL}$	4.5	5	5.5	V
$V_{PH}$	8.5	12	15	V
$V_{PP}$	25	26	27	V

Table 1: Voltage Level of Program Enable Pulse

4. Pots #1, 3, and 2 adjust  $V_{PP}$ ,  $V_{PH}$ , and  $V_{PL}$  respectively. NOTE: The pots are grey coded so they are not completely independent. An iterative approach on the sequence below will properly adjust the new programming levels.
  - o Turn Pot #1 to adjust the level of  $V_{PP}$ . Pot #1 will be at or near the maximum level to adjust  $V_{PP}$  to the nominal of 26 V.
  - o Turn Pot #3 to adjust  $V_{PH}$  to its nominal voltage of 12 V.
  - o Turn Pot #2 to adjust  $V_{PL}$  to 5 V.
  - o Continually update the program enable sequence with the software to see the effect of adjusting the voltage levels with the pots.

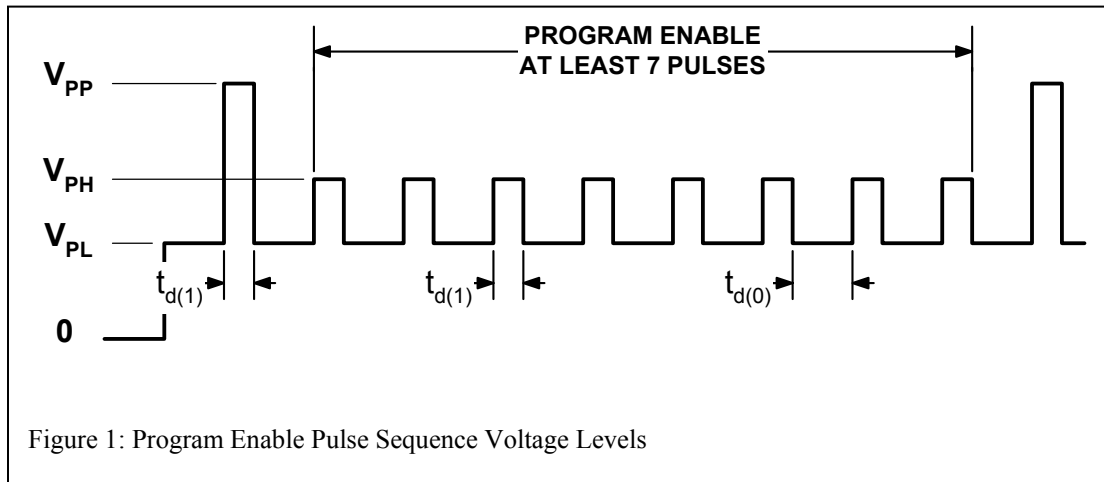

Figure 1: Program Enable Pulse Sequence Voltage Levels



MicroSystems, Inc.

