

## Ionization Smoke Detector with Interconnect

### Features and Benefits

- Low average standby current for long battery life
- Interconnect up to 125 detectors
- Piezoelectric horn driver
- Guard outputs for detector input
- Pulse testing for low battery
- Power-on reset (POR)
- Internal reverse battery protection
- Built-in hysteresis reduces false triggering
- Temporal horn pattern, per UL217, NFPA72, and ISO8201
- UL Recognized for UL217 or UL268 applications

### Package: 16-pin DIP (suffix A):

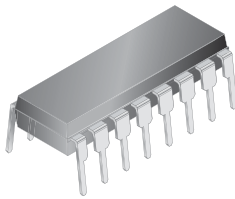

Not to scale

### Description

The A5364 is a low-current, BiCMOS circuit providing all of the required features for an ionization-type smoke detector. A networking capability allows as many as 125 units to be interconnected so that if any unit senses smoke all units will sound their alarm. In addition, special features are incorporated to facilitate alignment and test of the finished smoke detector. The device is Recognized by Underwriters Laboratories for use in smoke alarms that comply with Standard UL217 or UL268, per file #S2113.

The internal oscillator and timing circuitry keep standby power to a minimum by powering down the device for 1.66 seconds and sensing for smoke for only 10 ms. Every 24 on-off cycles, a check is made for a low battery condition. By substituting other types of sensors or a switch for the ionization detector, this very-low-power device can be used in numerous other battery-operated safety/security applications.

The A5364 is supplied in a low-cost 16-pin dual in-line plastic package (DIP). It is rated for continuous operation over the temperature range of  $-10^{\circ}\text{C}$  to  $60^{\circ}\text{C}$ . The Pb (lead) free version (suffix -T) has 100% matte tin leadframe plating.

### Typical Application

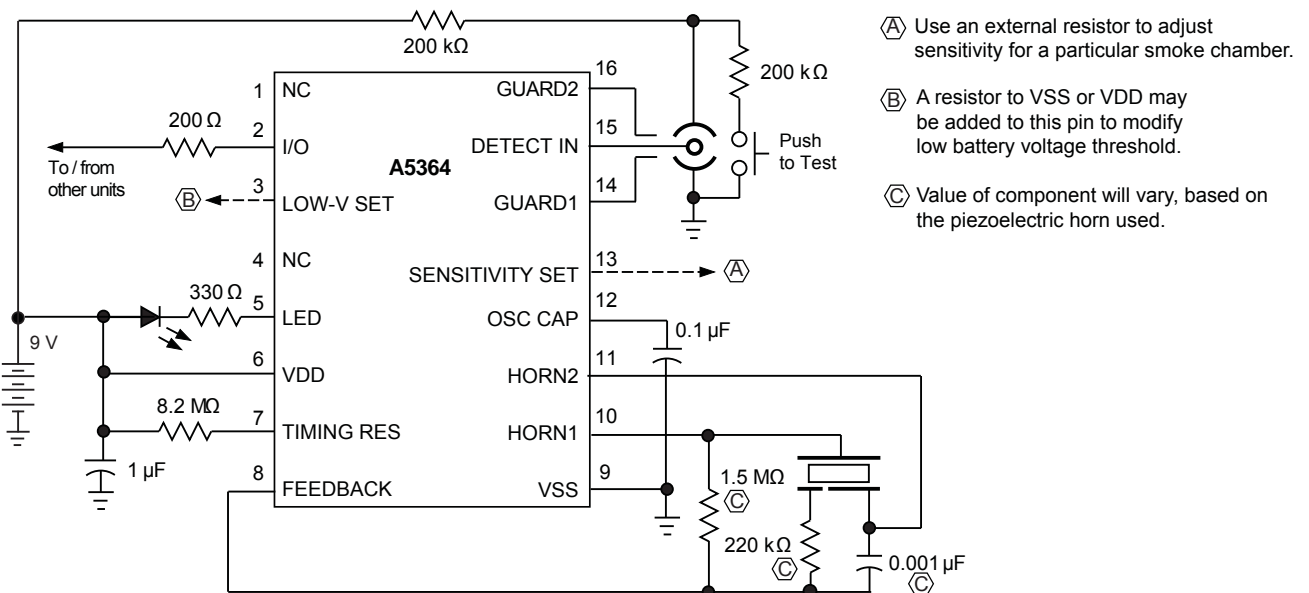

### Selection Guide

Part Number	Pb-Free	Packing
A5364CA	–	25 pieces per tube

### Absolute Maximum Ratings\*

Characteristic	Symbol	Notes	Rating	Units
Supply Voltage Range	$V_{DD}$	Referenced to $V_{SS}$	–0.5 to 15	V
Input Voltage Range	$V_{IN}$	Referenced to $V_{SS}$	–0.3 to $V_{DD} + 0.3$	V
Reverse Battery Condition Duration	$t_{RBAT}$	10.5 V	20	s
Input Current	$I_{IN}$		10	mA
Operating Ambient Temperature	$T_A$		–10 to 60	°C
Junction Temperature	$T_J(\text{max})$		150	°C
Storage Temperature Range	$T_{stg}$		–55 to 125	°C

\* CAUTION: BiCMOS devices have input static protection but are susceptible to damage when exposed to extremely high static electrical charges.

### THERMAL CHARACTERISTICS

Characteristic	Symbol	Test Conditions*	Value	Units
Package Thermal Resistance	$R_{\theta JA}$	4-layer PCB based on JEDEC standard	38	°C/W

\*Additional thermal information available on Allegro website.

### Terminal List Table

Number	Name	Function
1	NC	No connection
2	I/O	Input/output to interconnected detectors
3	LOW-V SET	Optionally used with a resistor to adjust low-battery threshold
4	NC	No connection
5	LED	Output to drive visible LED
6	VDD	Positive supply voltage
7	TIMING RES	Terminal for timing resistor, sets internal bias (affects timing)
8	FEEDBACK	Input for driving piezoelectric horn
9	VSS	Negative supply voltage
10	HORN1	Output for driving piezoelectric horn
11	HORN2	Complementary output for driving piezoelectric horn
12	OSC CAP	Terminal for charging/discharging an external capacitor to run the oscillator
13	SENSITIVITY SET	Optionally used with a resistor to adjust sensitivity for a specific chamber
14	GUARD1	Active guard 1 for detector input
15	DETECT IN	Input from detector chamber
16	GUARD2	Active guard 2 for detector input

### Pin-out Diagram

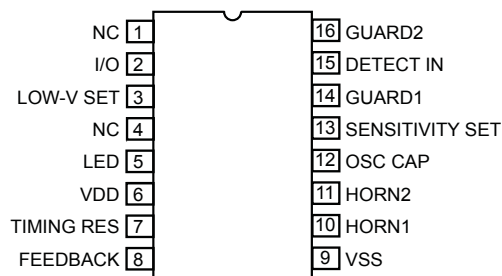

**Functional Block Diagram**

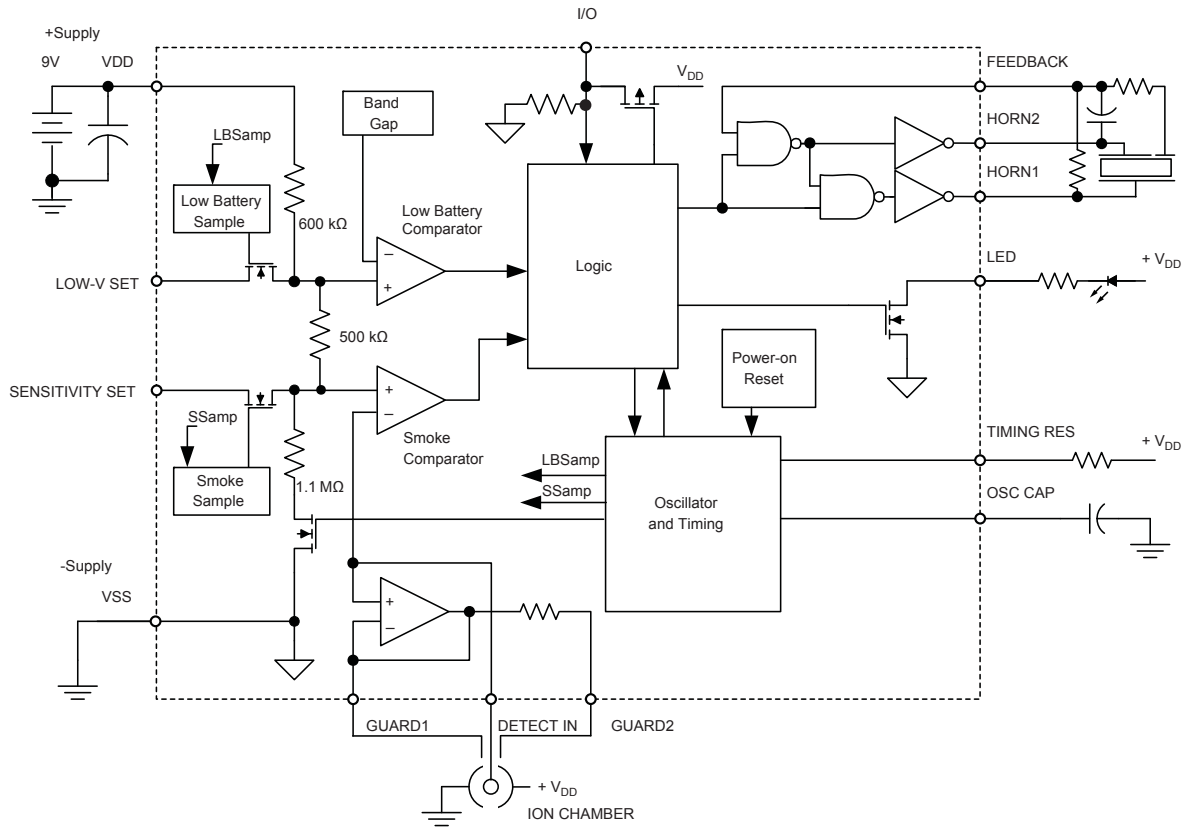

**ELECTRICAL CHARACTERISTICS**<sup>1,2</sup> at  $T_A = 25^\circ\text{C}$ ,  $V_{DD} = 9.0\text{ V}$ ,  $V_{SS} = 0\text{ V}$ ,  $C_{OSSCAP} = 0.1\ \mu\text{F}$ ,  
 $R_{TIMINGRES} = 8.2\ \text{M}\Omega$  (unless otherwise noted)

Characteristic	Symbol	Test Conditions	Test Pin	Min.	Typ.	Max.	Units
Supply Voltage Range	$V_{DD}$	Operating	6	6.0	9.0	12	V
Supply Current	$I_{DD}$	$V_{DD} = 9.0\text{ V}$ , no alarm, no loads	6	—	5.0	9.0	$\mu\text{A}$
		$V_{DD} = 12\text{ V}$ , no alarm, no loads	6	—	—	12	$\mu\text{A}$
Detector Input Current	$I_{DETECTIN}$	0% to 40% RH, $V_{IN} = 0$ to $9.0\text{ V}$	15	—	—	$\pm 1.0$	pA
Input Offset Voltage	$V_{OS(GUARD1)}$	Active GUARD1	14, 15	—	—	$\pm 100$	mV
	$V_{OS(GUARD2)}$	Active GUARD2	16, 15	—	—	$\pm 100$	mV
	$V_{OS}$	Detect comparator	15, 13	—	—	$\pm 50$	mV
Hysteresis	$V_{HYS}$	No alarm to alarm	13	90	130	170	mV
Common Mode Range	$V_{CM(\text{guard})}$	Guard amplifier	14, 15	2.0	—	$V_{DD} - 0.5$	V
	$V_{CM}$	Smoke comparator	13, 15	0.5	—	$V_{DD} - 2.0$	V
Active Guard Impedance	$Z_{AG1}$	GUARD1 to VSS	14	—	10	—	k $\Omega$
	$Z_{AG2}$	GUARD2 to VSS	16	—	500	—	k $\Omega$
Oscillator Period	$t_{osc}$	No alarm	12	1.34	1.67	2.00	s
	$t_{osc(\text{alarm})}$	Local or remote alarm	12	37.50	41.67	45.84	ms
Oscillator Pulse Width	$t_w(\text{osc})$		12	8.0	10	12	ms
Low-Battery Threshold	$V_{DD(\text{th})}$	$T_A = 0^\circ\text{C}$ to $50^\circ\text{C}$ , LOW-V SET open circuit	6	7.2	—	7.8	V
Sensitivity Adjust Voltage	$V_{SET}$	$V_{SENSITIVITYSET} / V_{DD}$ , SENSITIVITY SET open circuit	13	48.5	50	51.5	% $V_{DD}$
Horn Output Voltage	$V_{OL}$	$I_{OUT} = 16\text{ mA}$ , $V_{DD} = 9.0\text{ V}$	10, 11	—	0.1	0.5	V
		$I_{OUT} = 16\text{ mA}$ , $V_{DD} = 7.2\text{ V}$	10, 11	—	—	0.9	V
	$V_{OH}$	$I_{OUT} = -16\text{ mA}$ , $V_{DD} = 9.0\text{ V}$	10, 11	8.5	8.8	—	V
		$I_{OUT} = -16\text{ mA}$ , $V_{DD} = 7.2\text{ V}$	10, 11	6.3	—	—	V
Horn Output On-Time	$t_{on(\text{horn})}$	Local or remote alarm	10, 11	450	500	550	ms
	$t_w(\text{horn})$	Low battery	10, 11	8.0	10	12	ms
Horn Output Off-Time	$t_{off1(\text{horn})}$	Local or remote alarm (see Timing Diagrams section)	10, 11	450	500	550	ms
	$t_{off2(\text{horn})}$	Local or remote alarm (see Timing Diagrams section)	10, 11	1350	1500	1650	ms
	$t_{horn}$	Low battery	10, 11	32	40	48	s
LED Output-On Current	$I_{LED}$	$V_{DD} = 7.2\text{ V}$ , $V_{LED} = 1.0\text{ V}$	5	10	—	—	mA
LED Output On-Time	$t_w(\text{LED})$		5	8.0	10	12	ms
LED Output Off-Time	$t_{LED1}$	No alarm, in standby	5	32	40	48	s
	$t_{LED3}$	Local alarm or test alarm	5	0.76	0.97	1.14	s
	$t_{LED4}$	Remote alarm, no local smoke	5	—	No LED pulses	—	s

Continued on the next page...

**ELECTRICAL CHARACTERISTICS**<sup>1,2</sup> (continued) at  $T_A = 25^\circ\text{C}$ ,  $V_{DD} = 9.0\text{ V}$ ,  $V_{SS} = 0\text{ V}$ ,  $C_{OSCCAP} = 0.1\ \mu\text{F}$ ,  $R_{TIMINGRES} = 8.2\ \text{M}\Omega$  (unless otherwise noted)

Characteristic	Symbol	Test Conditions	Test Pin	Min.	Typ.	Max.	Units
I/O Current	$I_{IOL}$	No alarm, $V_{I/O} = V_{DD} - 2.0\text{ V}$	2	25	—	60	$\mu\text{A}$
	$I_{IOH}$	Local alarm, $V_{I/O} = V_{DD} - 2.0\text{ V}$	2	-7.5	—	—	mA
I/O Alarm Voltage	$V_{IH(I/O)}$	External "alarm" in	2	3.0	—	—	V
I/O Delay	$t_{r(I/O)}$	Local or test alarm to I/O active	2	—	3.0	—	s

<sup>1</sup>Negative current is defined as coming out of the specified device pin (sourcing).

<sup>2</sup>Alarm (smoke) condition is defined as  $V_{DETECTIN} < V_{SENSITIVITYSET}$ ; no alarm (no smoke) condition is defined as  $V_{DETECTIN} > V_{SENSITIVITYSET}$ .

## Circuit Description

The A5364 is a low-current, BiCMOS circuit providing all of the required features for an ionization-type smoke detector.

### Oscillator

An internal oscillator operates with a period of 1.67 seconds during no-smoke conditions. Every 1.67 seconds, internal power is applied to the entire circuit for 10 ms and a check is made for smoke. Every 24 clock cycles (approximately 40 seconds), the LED pin is pulsed and a check is made for low battery by comparing  $V_{DD}$  to an internal reference. Because very-low currents are used in the device, the oscillator capacitor at the OSC CAP pin should be a low-leakage type (PTFE, polystyrene, or polypropylene).

### Detector Circuitry

When the voltage on the DETECT IN pin is less than the voltage on the SENSITIVITY SET pin, the A5364 evaluates this as a *smoke condition*. During a smoke condition, the resistor divider network that sets the sensitivity (also referred to as the *smoke trip point*) is altered to increase  $V_{SENSITIVITYSET}$  by 130 mV typical (with no external connections on the SENSITIVITY SET pin). This provides hysteresis and reduces false triggering.

An active guard is provided on GUARD1 and GUARD2, the two pins adjacent to the detector input, the DETECT IN pin.  $V_{GUARD1}$  and  $V_{GUARD2}$  will be within 100 mV of  $V_{DETECTIN}$ . This will keep surface leakage currents to a minimum and provide a method of measuring the input voltage without loading the ionization chamber. The active guard amplifier is not power strobed and thus provides constant protection from surface leakage currents. The detector input has internal diode protection against electrostatic damage.

### Alarm Circuitry

If smoke is detected, the oscillator period changes to 40 ms and the horn is enabled. The horn output follows a temporal horn pattern of nominally: 0.5 s on, 0.5 s off, 0.5 s on, 0.5 s on, 1.5 s off. During the off-time, smoke is checked and further alarm output will be inhibited if smoke is not sensed. During a smoke condition, the low-battery alarm is inhibited and the LED is pulsed approximately once every second.

### Sensitivity Adjust

The detector sensitivity to smoke is set internally by a voltage divider connected between VDD and VSS. The sensitivity can, however, be externally adjusted to the individual characteristics

of the ionization chamber by connecting a resistor between the SENSITIVITY SET pin and either the VDD or VSS pins.

With no external connections on the SENSITIVITY SET pin, while the A5364 is checking for smoke:

$$V_{\text{SENSITIVITYSET}} = V_{\text{DD}} / 2 .$$

To increase sensitivity, a resistor can be connected between SENSITIVITY SET and VDD, with the value:

$$R_{\text{SENSITIVITYSET}} = 1.1\text{E}6 \times K / (1 - K) ,$$

where

$$K = V_{\text{DD}} / V_{\text{SENSITIVITYSET}} - 1 .$$

To decrease sensitivity, a resistor can be connected between SENSITIVITY SET and VSS, with the value:

$$R_{\text{SENSITIVITYSET}} = 1.1\text{E}6 \times K / (1 - K) ,$$

where

$$K = 1 / (V_{\text{DD}} / V_{\text{SENSITIVITYSET}} - 1) .$$

### Low Battery

The low battery condition threshold is set internally by a voltage divider connected between VDD and VSS. The threshold can be externally adjusted by connecting a resistor between the LOW-V SET pin and either the VDD or VSS pins.

To increase the threshold, a resistor can be connected between LOW-V SET and VSS. Given an initial threshold,  $V_{(\text{th})\text{init}}$  (nominally 7.5 V), and a target threshold,  $V_{(\text{th})\text{set}}$ , the resistor should have the value:

$$R_{\text{LOWVSET}} = 600\text{E}3 \times K / (1 - 0.375 \times K) ,$$

where

$$K = 1 / (V_{(\text{th})\text{set}} / [0.727 \times V_{(\text{th})\text{init}}] - 1) .$$

To decrease the threshold, a resistor can be connected between LOW-V SET and VDD. Given an initial threshold,  $V_{(\text{th})\text{init}}$  (nominally 7.5 V), and a target threshold,  $V_{(\text{th})\text{set}}$ , the resistor should have the value:

$$R_{\text{LOWVSET}} = 960\text{E}3 \times K / (0.6 - 1.6 \times K) ,$$

where

$$K = V_{(\text{th})\text{set}} / (0.727 \times V_{(\text{th})\text{init}}) - 1 .$$

The battery voltage level is checked approximately every 40 seconds during the (approximately) 10 mA, 10 ms LED pulse. If an LED is not used, it should be replaced with an equivalent resistor (typically 500 to 1000  $\Omega$ ) such that the battery loading remains about 10 mA.

### I/O

A connection to the I/O pin allows multiple smoke detectors to be interconnected. If any single unit detects smoke, its I/O pin is driven high (after a nominal 3 s delay), and all connected units will sound their associated horns. When the I/O pin is driven high by another device, the oscillator immediately speeds up to its 41.7 ms period. The remainder of the sped-up clock cycle, and two additional consecutive clock cycles with I/O high are required to cause an alarm. If the I/O pin falls below its threshold at any time during those (approximately) 83.4 ms, an internal latch is reset and there will not be an alarm. Thus, the I/O must remain high for (approximately) 93.9 ms in order to cause an alarm. This filtering provides significant immunity to I/O noise.

The LED is suppressed when an alarm is signaled from an interconnected unit, and any local alarm condition causes the I/O pin to be ignored as an input. This pin has an on-chip pulldown device and must be left unconnected if not used.

### Testing

On power-up, all internal counters are reset. Internal test circuitry allows low battery check by holding the FEEDBACK and OSC CAP pins low during power-up, then reducing  $V_{\text{DD}}$  and monitoring the HORN1 pin. HORN1 will be driven high when  $V_{\text{DD}}$  falls below the low-battery threshold. All functional tests can be accelerated by driving the OSC CAP pin with a 2 kHz square wave. The 10 ms strobe period must be maintained for proper operation of the comparator circuitry.

**Timing Diagrams  
(Not to scale)**

▮ Test event

**Standby Mode**

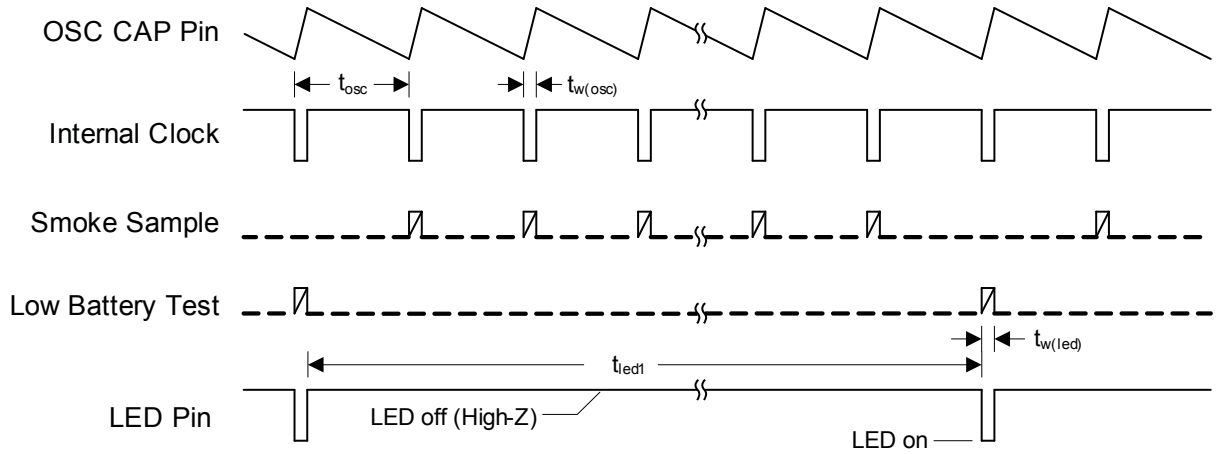

**Low Battery Condition**

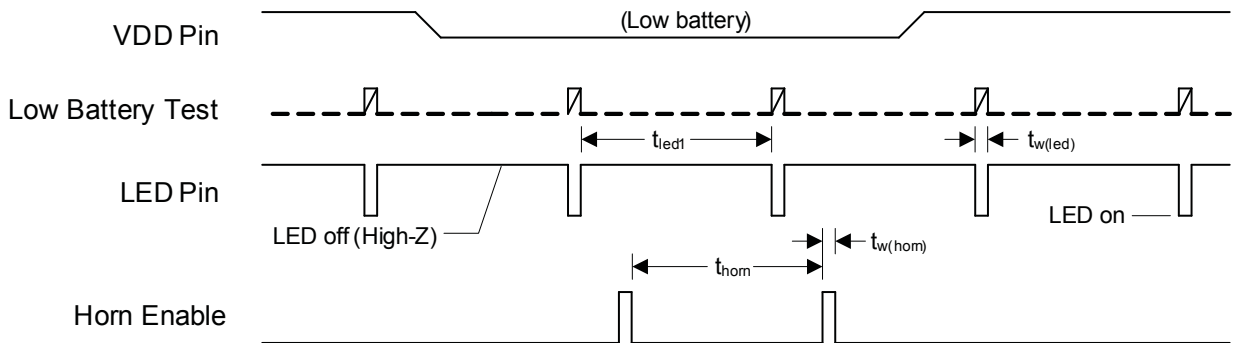

**Local Smoke Detection/Test Alarm Condition**

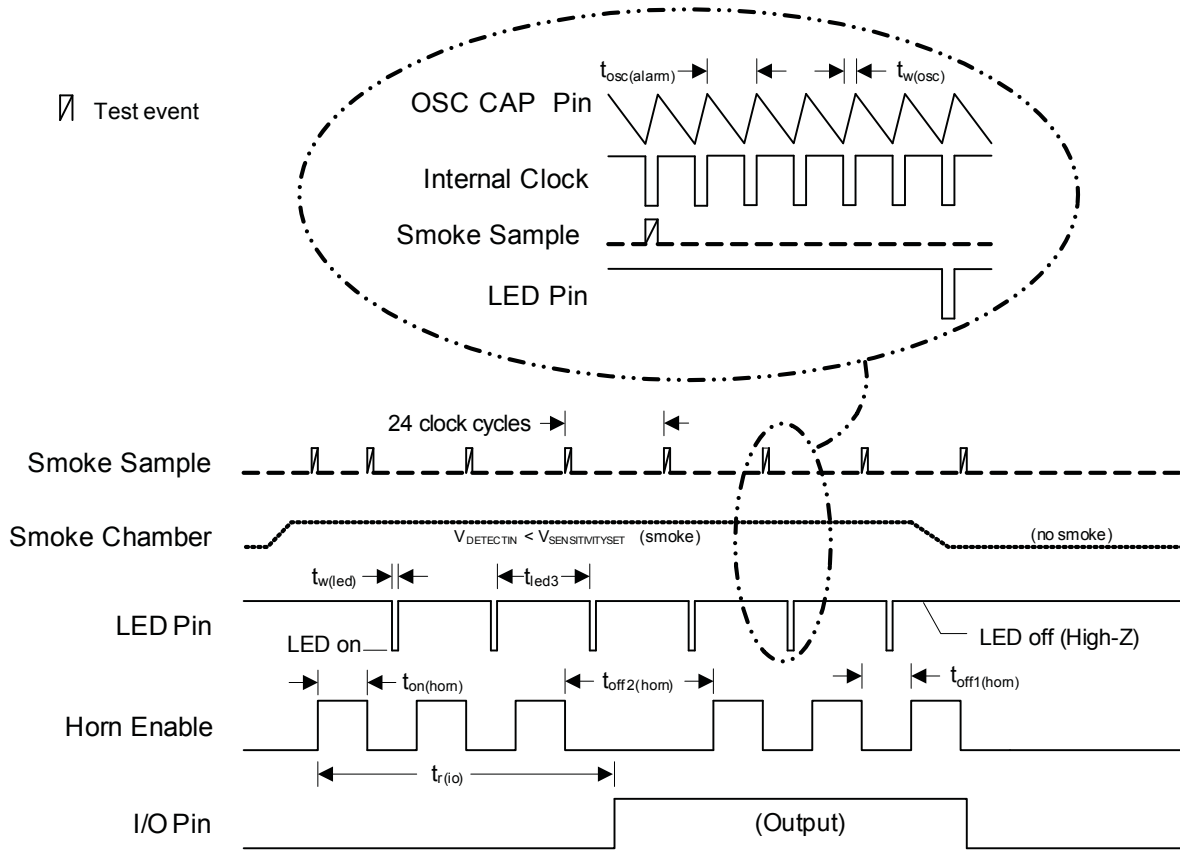

**Remote Alarm Condition**

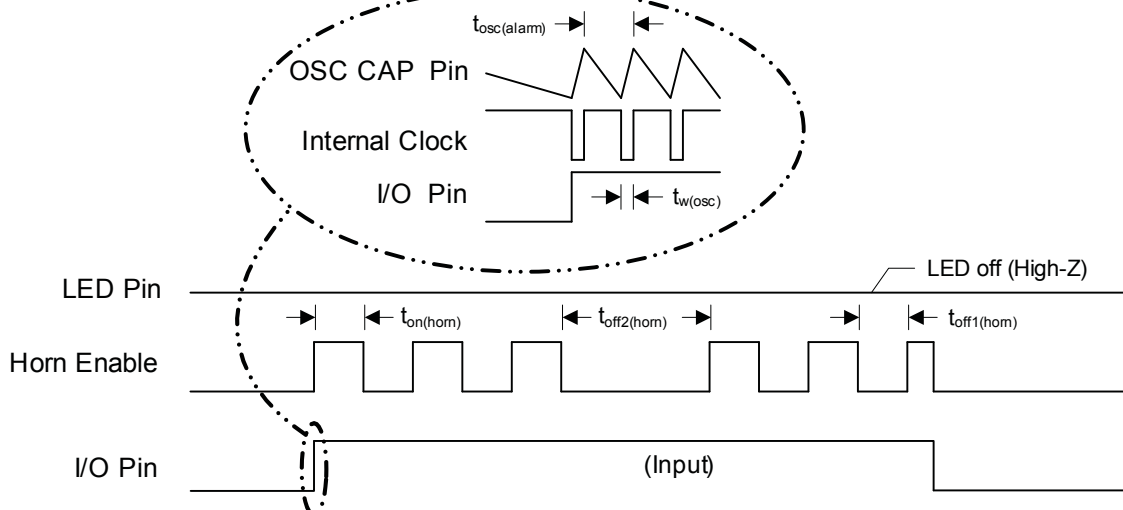

**Package A, 16-Pin DIP**

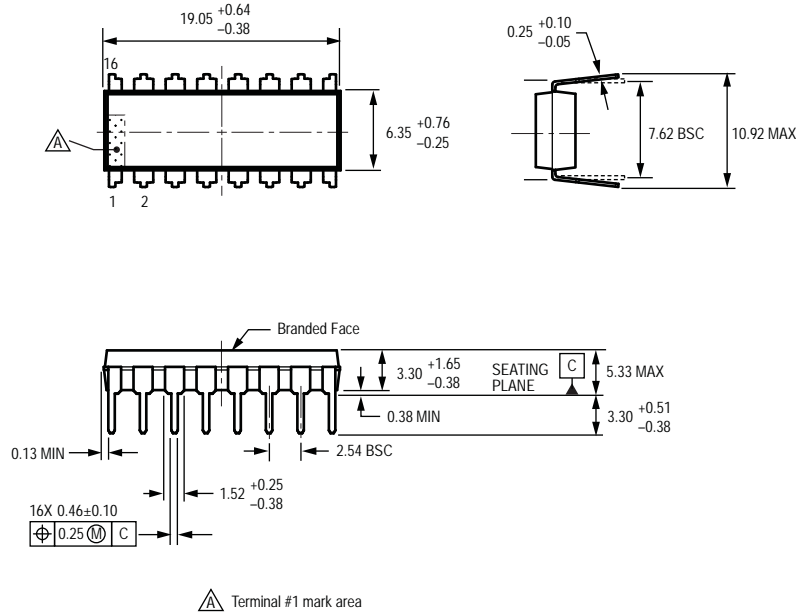

For Reference Only; not for tooling use (reference MS-001BB)  
 Dimensions in millimeters  
 Dimensions exclusive of mold flash, gate burrs, and dambar protrusions  
 Exact case and lead configuration at supplier discretion within limits shown

Allegro MicroSystems offers an industry-leading range of ionization and photoelectric smoke detector ICs. For a current listing, please visit our website at:

[www.allegromicro.com](http://www.allegromicro.com)

Copyright ©2001-2009, Allegro MicroSystems, Inc.

The products described here are manufactured under one or more U.S. patents or U.S. patents pending.

Allegro MicroSystems, Inc. reserves the right to make, from time to time, such departures from the detail specifications as may be required to permit improvements in the performance, reliability, or manufacturability of its products. Before placing an order, the user is cautioned to verify that the information being relied upon is current.

Allegro's products are not to be used in life support devices or systems, if a failure of an Allegro product can reasonably be expected to cause the failure of that life support device or system, or to affect the safety or effectiveness of that device or system.

The information included herein is believed to be accurate and reliable. However, Allegro MicroSystems, Inc. assumes no responsibility for its use; nor for any infringement of patents or other rights of third parties which may result from its use.

For the latest version of this document, visit our website:

[www.allegromicro.com](http://www.allegromicro.com)

