

PARALLEL-TO-SERIAL DATA CONVERTER

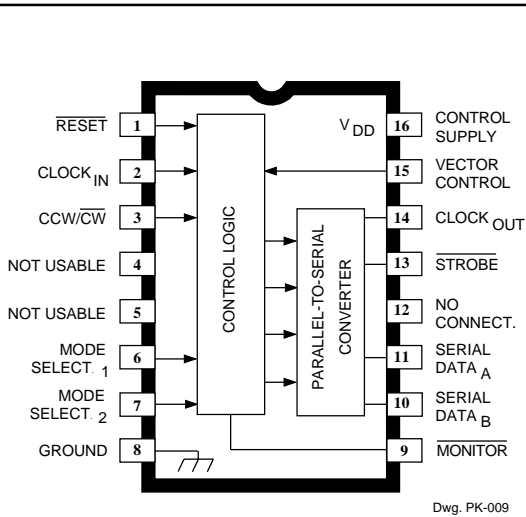

The PG001M CMOS IC converts parallel-data signals from a low-cost, 8-bit microprocessor or microcontroller into a serial-data format compatible with the SLA7042M and SLA7044M power multi-chip modules to drive unipolar PWM, high-current stepper motors. The converter provides for five basic modes of operation:

- 1) normal, two-phase, full step (100% torque vector),
- 2) two-phase 'boosted' torque (141% torque vector),
- 3) half-step, constant torque operation (using a 2-1-2 output switching),
- 4) quarter-stepping utilizing ratioed currents for constant torque, and
- 5) microstepping (1/8th steps) for quiet, smooth, resonance-free motor performance.

The PG001M is supplied in a low-cost 16-pin dual in-line plastic package. It is rated for continuous operation over the temperature range of -20°C to +85°C.

ABSOLUTE MAXIMUM RATINGS

Supply Voltage, V_{DD}	7.0 V
Input Voltage Range, V_I	-0.5 V to $V_{DD} + 0.5$ V
Input Current, I_I	± 10 mA
Output Voltage Range, V_O	-0.5 V to $V_{DD} + 0.5$ V
Output Current, I_O	± 15 mA
Operating Temperature Range, T_A	-20°C to +85°C
Storage Temperature Range, T_S	-40°C to +150°C

CAUTION: CMOS devices have input static protection but are susceptible to damage if exposed to extremely high static electrical charges.

FEATURES

- Intended For Use With SLA7042M or SLA7044M Microstepping, Unipolar PWM, High-Current Motor Drivers
- Supports Five Stepper-Motor Operating Modes
- μ P-Compatible Inputs

Always order by complete part number, **PG001M**.

PG001M PARALLEL-TO-SERIAL DATA CONVERTER

*Integrated
Circuits*

FUNCTIONAL BLOCK DIAGRAM

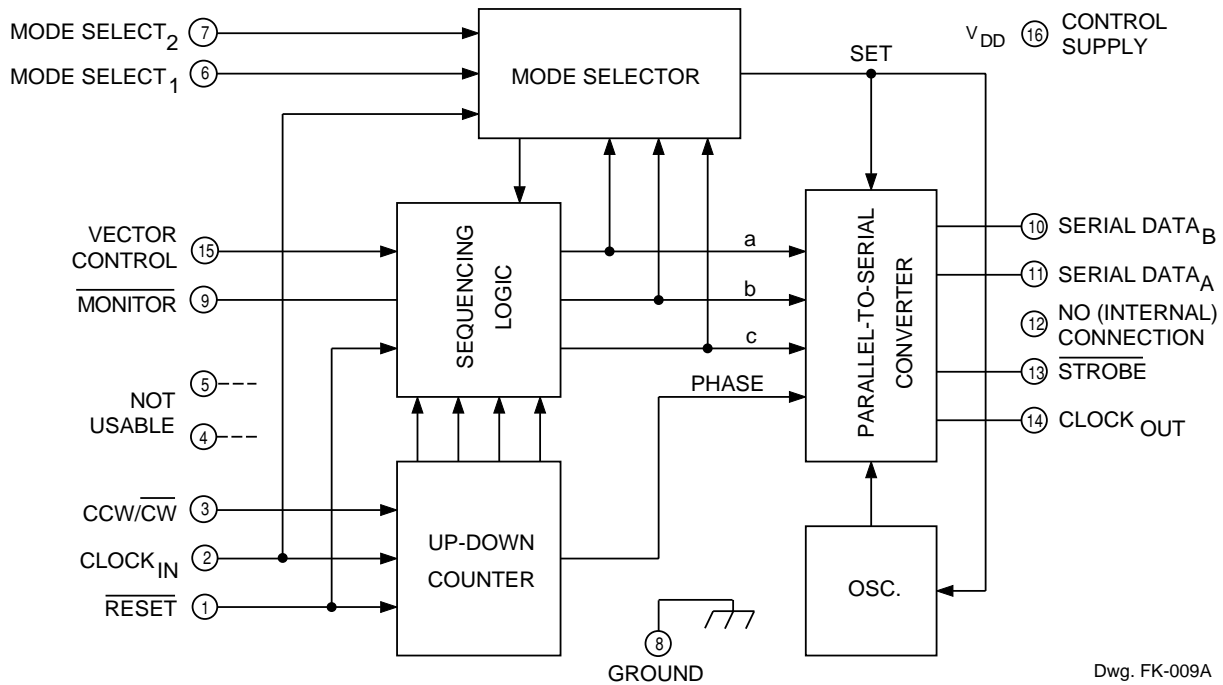

TRUTH TABLE

Motor Excitation	PG001M Inputs			SLA7042/44M Output Sequence & PWM Current							Motor Torque	
				0	1	2	3	4	5	6		7
	VC	MS ₁	MS ₂	0%	20%	40%	55.5%	71.4%	83%	91%		100%
Full Step	H	L	L	–	–	–	–	–	–	–	■	141%
	L	L	L	–	–	–	–	■	–	–	–	100%
Half Step	X	H	L	■	–	–	–	■	–	–	■	100%
1/4 Step	X	L	H	■	–	■	–	■	–	■	■	100%
1/8 Step	X	H	H	■	■	■	■	■	■	■	■	100%

This data sheet is based on Sanken data sheet SSJ-01367.

ELECTRICAL CHARACTERISTICS at $T_A = +25^\circ\text{C}$, $V_{DD} = 5\text{ V}$ (unless otherwise noted).

Characteristic	Symbol	Test Conditions	Limits			Units
			Min.	Typ.	Max.	
Supply Voltage	V_{DD}	Operating	4.5	–	5.5	V
Output Voltage	V_{OH}	$I_O = -3\text{ mA}$	4.5	4.6	–	V
	V_{OL}	$I_O = 3\text{ mA}$	–	0.3	0.4	V
Input Current	I_{IH}	$V_I = 5\text{ V}$	–	–	1.0	μA
	I_{IL}	$V_I = 0\text{ V}$	–	–	-1.0	μA
Input Voltage	V_{IH}		3.5	–	5.0	V
	V_{IL}		0	–	1.5	V
	V_{hys}		–	1.0	–	V
Internal Oscillator Freq.	f_{osc}		–	1.5	–	MHz
Delay Time	$t_{d(CIH-COH)}$	CLK _{IN} to CLK _{OUT} rising edges	–	50	100	ns
	$t_{d(CIL-SL)}$	CLK _{IN} to STROBE falling edges	–	430	550	ns
Output Switching Time	t_r	$C_L = 15\text{ pF}$, 10% to 90%	–	20	–	ns
	t_f	$C_L = 15\text{ pF}$, 90% to 10%	–	20	–	ns
CLOCK _{IN} Pulse Width	t_{ckH}		4.5	–	–	μs
	t_{ckL}		0.5	–	–	μs
Input Capacitance	C_i		–	5.0	10	pF
Supply Current	I_{DD}	$V_{DD} = 5.5\text{ V}$	–	350	450	μA

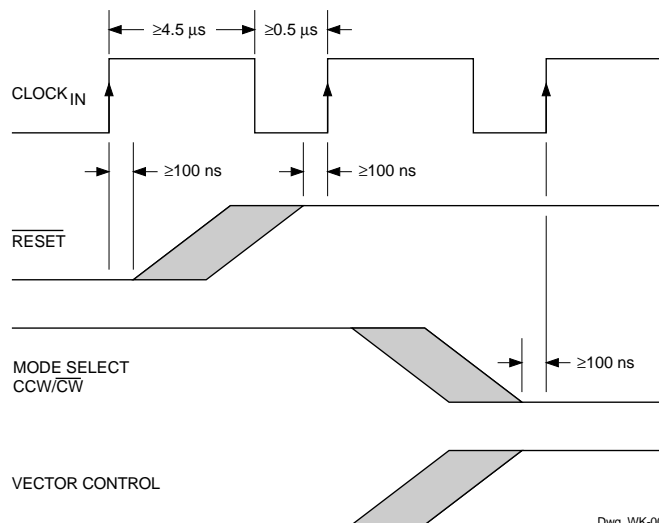

PG001M Input Signals Timing

PG001M
PARALLEL-TO-SERIAL
DATA CONVERTER

*Integrated
Circuits*

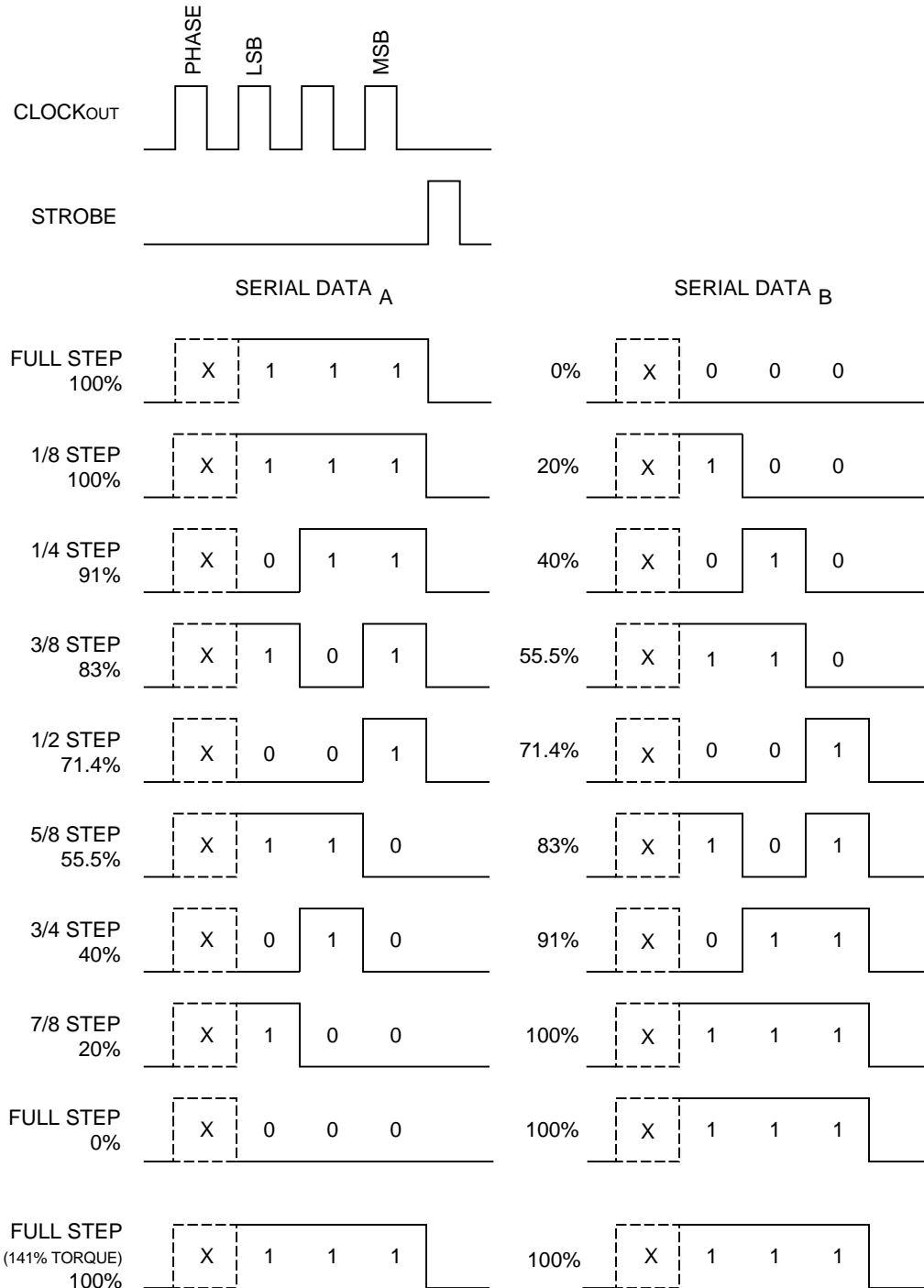

Dwg. WK-007

CLOCK, STROBE, and SERIAL DATA Outputs for Microstepping

PG001M DESCRIPTION AND OPERATION

The PG001M is a CMOS step-motor control IC that converts parallel-input signals from a microprocessor (μP , or microcontroller, μC) to the serial-input data format required for control of an SLA7042M or SLA7044M microstepping, unipolar PWM, high-current motor driver.

This control IC offers five basic modes of motor operation:

- 1) normal 2-phase, full-step (100% torque vector);
- 2) 2-phase, full-step 'boosted' torque (141% vector);
- 3) 1/2-step, constant torque operation (i.e., 2-1-2 switching);
- 4) 1/4-step operation with current-ratioed constant torque; and
- 5) smooth microstepping operation (1/8th step) for resonance-free motor performance (constant torque with eight output current ratios).

Three inputs (VC , MS_1 , and MS_2) control these five operational modes (as shown in figure 1); this enables designers to change the drive method during movement to realize optimal performance.

Initially, at start-up, the high-torque mode can provide 141% torque (the resulting vector of both motor windings at 100% current). This enhances rapid acceleration (and deceleration). Switching to quarter-stepping or microstepping (after initial, startup acceleration) offers smooth, resonance-free operation during the ramp-up interval. The transition to quarter- or microstepping should occur before the increasing step rate approaches the motor resonance frequency (usually 100 to 200 Hz).

The modes of operation and current-control truth table are listed on page 2; and there are two full-step, 2-phase (2-2) operating modes. The VECTOR CONTROL input (VC) can only be changed when MONITOR (MO , a readback pin) is LOW and the PG001M is operating in the full-step mode. Starting (or stopping) the step motor with VC HIGH delivers the highest torque (141%) from the motor, and is the extension of two outputs ON at 71.4%. This 'half-step' rotor position corresponds to the state when MO is LOW, and switching the control inputs to another operating mode is allowed.

The PG001M accepts logic signals from the μP and converts these into the proper serial-data format required to control the serial-data input lines of the SLA7042M or SLA7044M microstepping power modules. The five

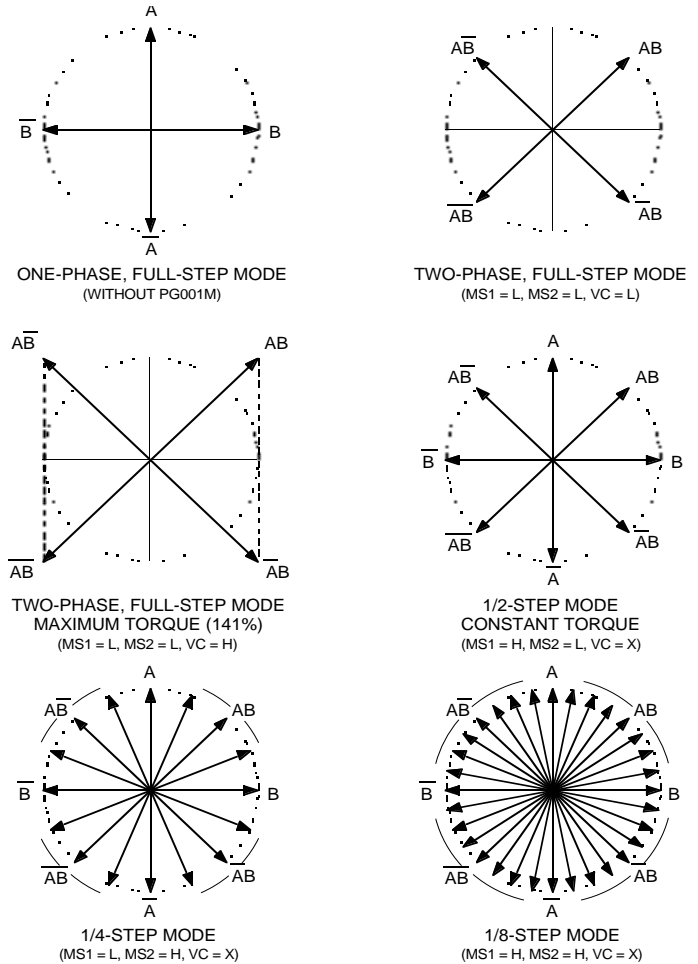

Dwg. OP-005
NOTE – Mode change only allowed at half-step positions (refer to upper right figure).

Figure 1 — Current/Displacement Vectors

control inputs determine the various modes of operation. The $\text{CLOCK}_{\text{OUT}}$, SERIAL DATA_A , SERIAL DATA_B , and STROBE to the SLA7042/44M are synchronized to the CLOCK_{IN} of the PG001M; and the CLOCK_{IN} frequency is eight times the step rate (more to follow on the signal/timing relationships).

The internal logic and oscillator combine to convert the parallel input signals to 'bursts' of serial data from the

PG001M PARALLEL-TO-SERIAL DATA CONVERTER

Integrated
Circuits

CLOCK_{OUT}, SERIAL DATA_A, SERIAL DATA_B, and STROBE. In the full-step modes the clock, data, and strobe pulses are 1/8 the input clock rate; while half-step operation produces 'bursts' at 1/4 the input clock rate. Further, quarter-step mode signals correspond to 1/2 the input clock frequency; while during microstepping the signal 'bursts' equal the input clock rate. Hence, the step rate is always 1/8th the input clock frequency, regardless of the operating mode. Obviously, the clock rate increases while accelerating, becomes constant during slewing, and decreases as the step motor and load are decelerating.

Microstepping Operation

Figures 1 and 2 illustrate the incremental eight step divisions provided while microstepping. The 3-bit sequence from 0 through 8 provides smooth, constant-torque operation that is delivered to the motor/load by the SLA7042M or SLA7044M power multi-chip modules.

The circle in figure 1 and the arc in figure 2 represent the constant-torque vectors. Slight discrepancies are evident when examining the vector 'arrows'. The disparity is insignificant, and will not affect smooth, resonance-free motion. However, it may affect realizing accurate and precise intermediate positioning. Subdividing steps into

eight distinct, exact positions is often very challenging. Clearly, variation in the phase currents affects rotor displacement, and is a very crucial factor in resolving accurate, intermediate step divisions.

Another critical factor to realizing precise, repeatable step subdivisions pertains to the selection and evaluation of the step motor. The better motors exhibit uniformly spaced positioning characteristics. However, torque vs displacement characteristics vary (often greatly). Usually, precise step subdivisions require motors designed for microstepping.

An 'Integrated' Microstepping Design

The combination of CMOS controller IC and microstepping power module is depicted in figure 3. The μ P provides the needed logic signals that reset the counter, control rotor direction, determine the operating mode, and change the current/torque vector (during full-step, 2-phase operation).

The sequencing logic provides a 'readback' signal (the MO output) that switches LOW at the half-step position when the microcontroller can shift control modes and not incur oscillation/vibration problems. The mode change is allowed at the 45° vector, half-step position shown in figure 2. In addition to the 45° AB vector, three other half-step vectors occur during stepping: AB at 135°, AB at 225°, and AB at 315° (figure 1). These current vectors correspond to the half-step positions in four quadrants, and four 2-phase, full steps of rotation.

The Parallel-to-Serial Conversion

Perhaps the greatest system advantage for designers is the simplification of software. Controlling and operating the SLA7042/44M power multi-chip modules directly would require programming the system μ P to provide and update serial data to both the A and B inputs, and signals to the clock and strobe inputs that control the A and B sections of the driver.

Although designs utilizing the CMOS control IC require seven I/O lines, the software program will be simpler and shorter. The system μ P provides logic signals that control RESET, CCW/CW (direction), MODE SELECT₁, MODE SELECT₂, VECTOR CONTROL, and read the MONITOR return. Only the CLOCK input is a 'dynamic', constantly switching signal from the system control I/O.

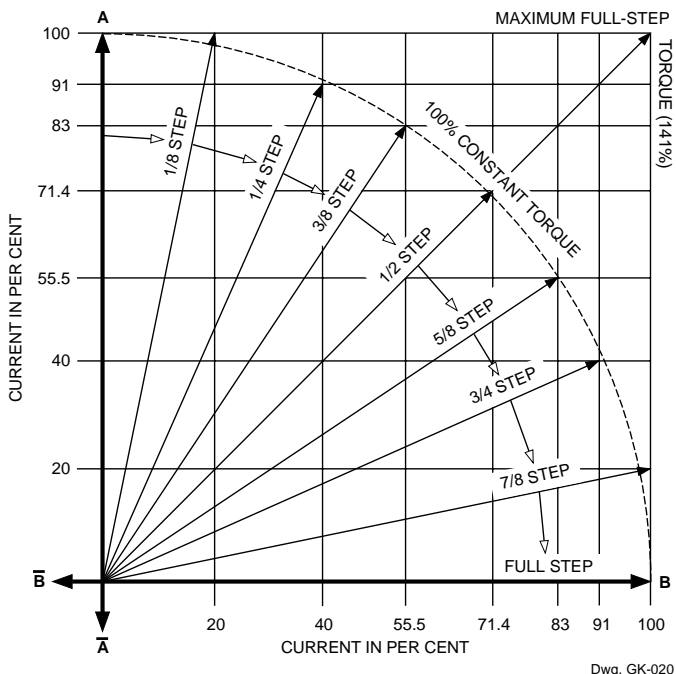
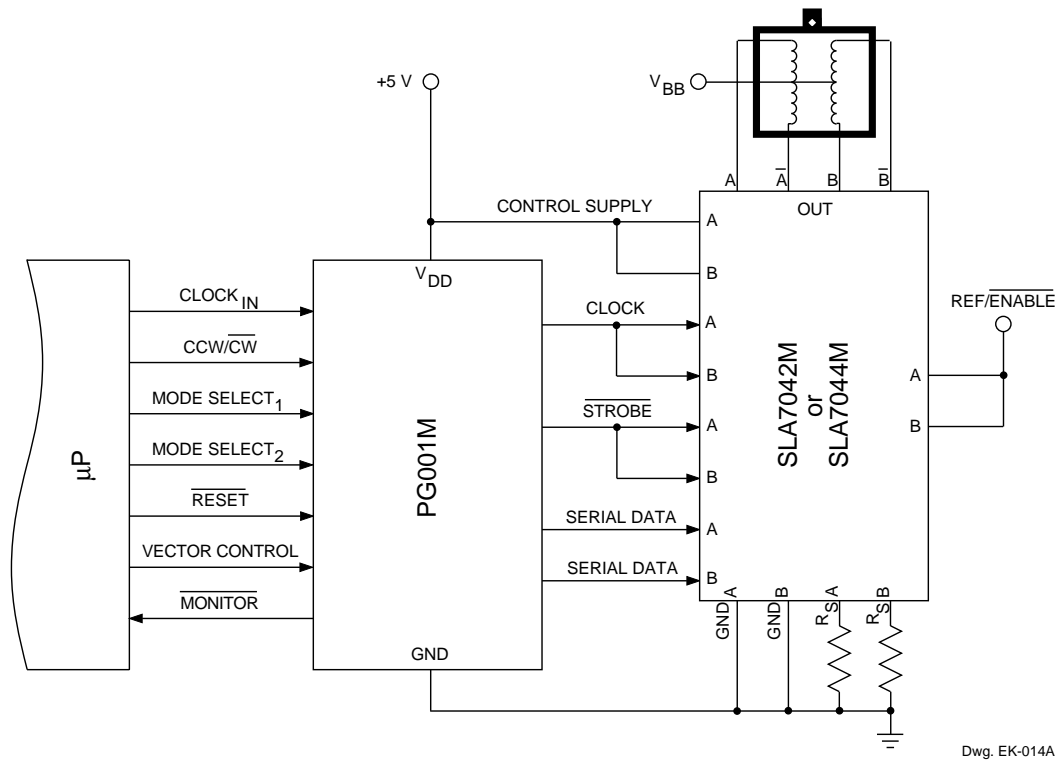

Figure 2 — Current/Displacement Vectors



Dwg. EK-014A

Figure 3 — Typical 'Integrated' Microstepping System

Depicted in figure 4 are the 'front-end' I/O signals (from RESET to VECTOR CONTROL), converted signals from the controller IC to the microstepping power module (CLOCK_{OUT}, SERIAL DATA_A, SERIAL DATA_B, and STROBE), plus the MONITOR (readback) to the microcontroller. Finally, the power multi-chip module current ratios are illustrated (OUT_A and OUT_B).

As shown, initially the counter is reset, and then the motor is operating in quarter-step mode; then MS₂ is switched while MO is LOW. The two steps following are full-step (100% torque vector). The final (fourth quadrant) portion of figure 4 is the maximum (141%) torque mode, after VECTOR CONTROL has been switched from LOW to HIGH. Three of the five operational modes are shown, and none require the μP to continually update the clock, serial-data input, or strobe to the SLA7042/44M module.

The microstepping operation is illustrated in figure 5. Initially the counter is reset, and with both MODE SELECTs HIGH the controller is furnishing clock, serial data, and strobe logic signals for 1/8th step increments.

After the RESET pulse, the first (two) full-steps in the microstepping sequence, MS₁ is switched LOW and the control IC shifts into the 1/4-step mode. It becomes very apparent that any microstepping directly from a μP to the SLA7042/44M module 'burdens' the μP, complicates the software, and might entail a 'dedicated' microcontroller in many motion-control systems.

The PG001M controller IC precludes loading a μP with direct serial-data signals to the power multi-chip module. Because the step motor is updated at eight times the step rate, this CMOS IC both simplifies software and eliminates loading a system microprocessor with 'house-keeping' control of step motors.

As illustrated in figures 4 and 5, the controller IC eliminates the requirement to program the system for the various modes of operation and the continual updating of the serial-data signals to the power multi-chip module. NOTE — In figures 4 and 5, the clock frequency is constant during the few steps of operation that are shown and half-step operation is not included.

PG001M PARALLEL-TO-SERIAL DATA CONVERTER

Integrated
Circuits

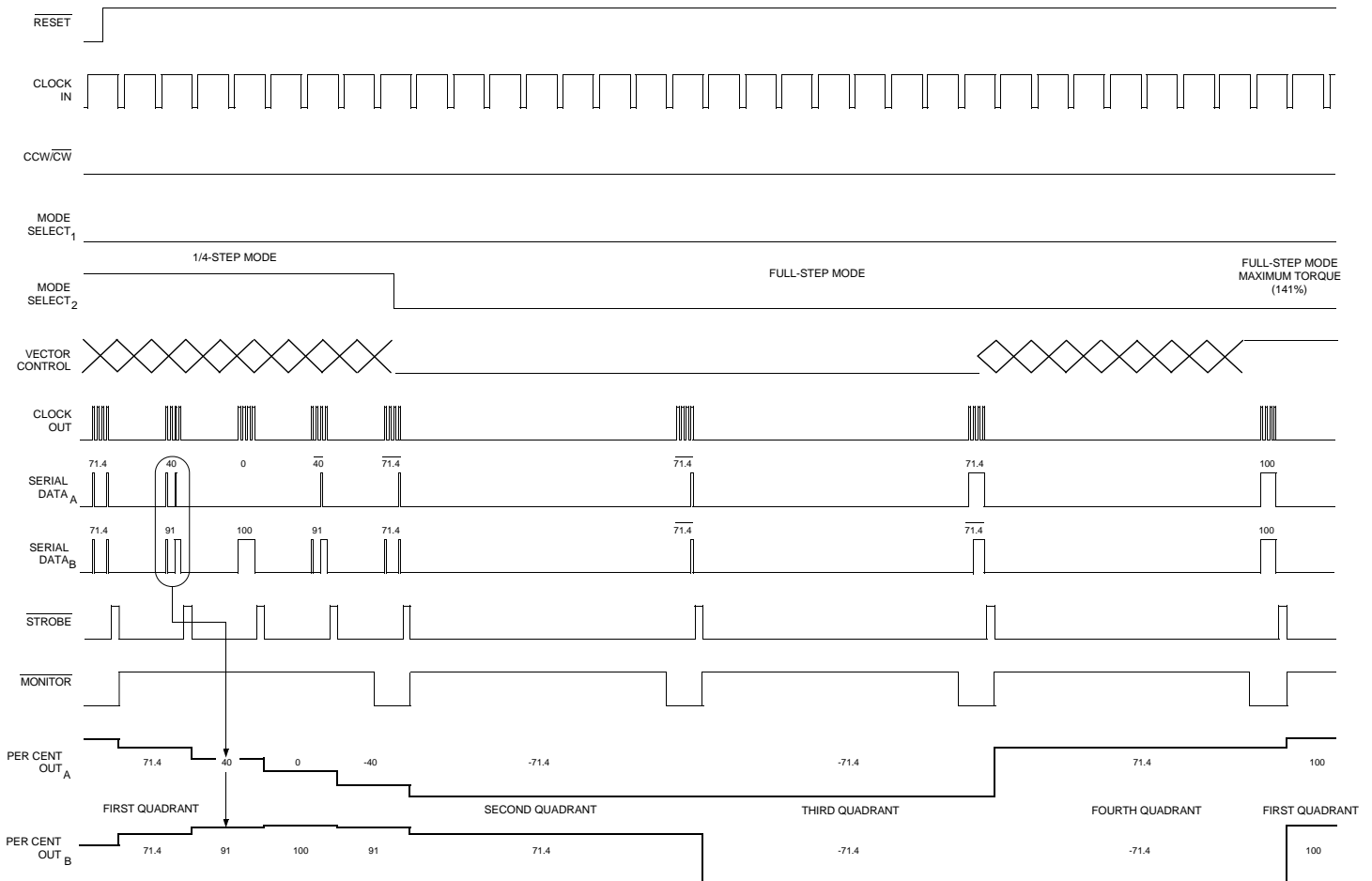

Dwg. WK-006

Figure 4 — Quarter-Step, Full-Step, and High-Torque Full-Step

Because the parallel-to-serial conversion requires six 'static' logic signals plus a 'dynamic' (clock) input, the addition of latches between the μ P and five of the controller IC inputs permits use on a bus. Latching the five signals to CCW/CW, MS₁, MS₂, RESET, and VC frees these five I/O lines for other operations by the microcontroller. Even at extremely high step rates (>5 kHz), updating the PG001M input data requires an infinitesimal percentage of the μ P's I/O and control operations.

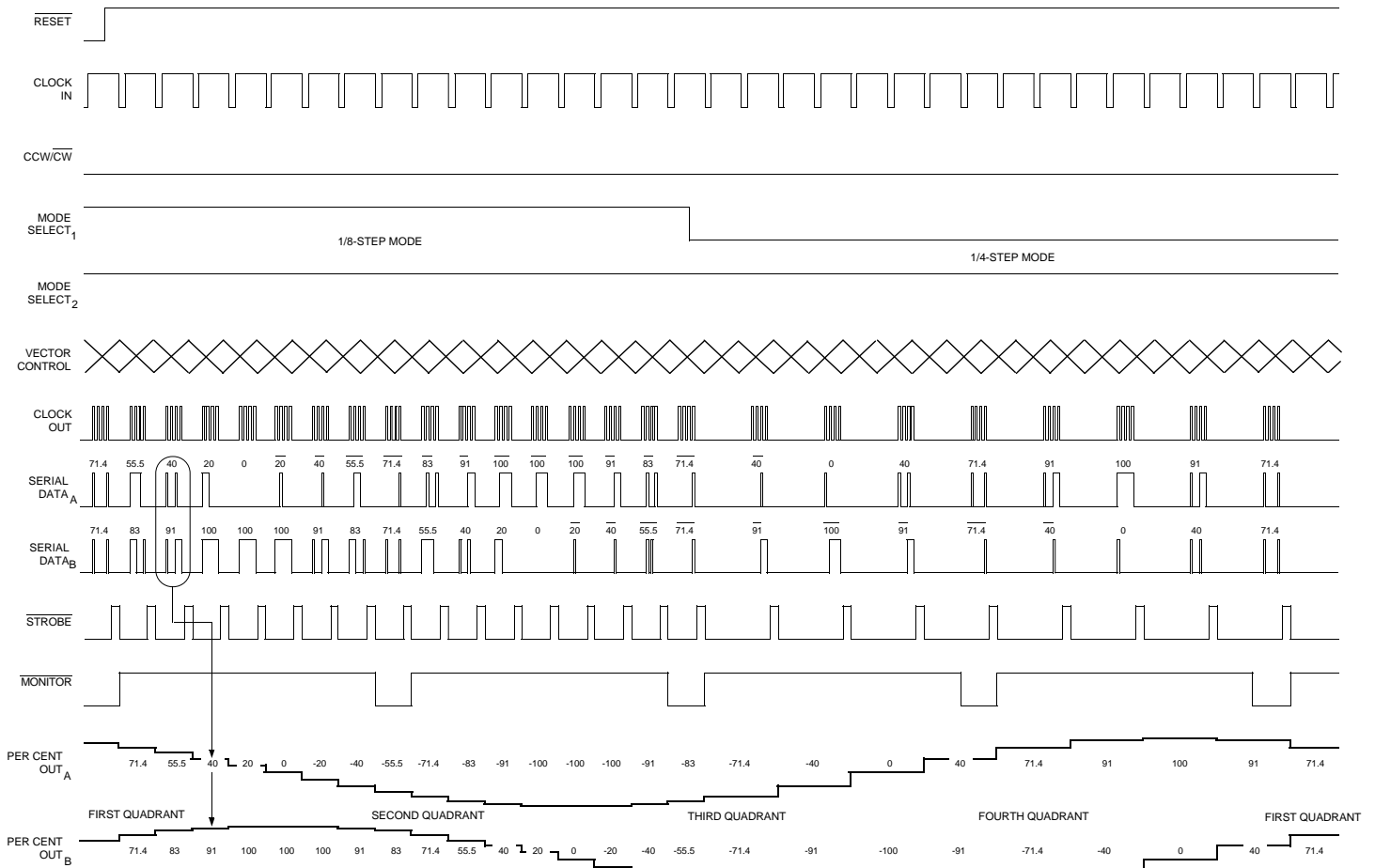

Dwg. WK-006-1

Figure 5 — Microstepping (1/8th-Step) and Quarter-Step Modes

One technique to free μP I/O lines for shared functions is depicted in figure 6. The I/O lines required (without latches) are then transformed into three 'dedicated' logic inputs; a STROBE is added, and CLOCK and MONITOR retained. CLOCK, RESET, MODE SELECT₁, MODE SELECT₂, and VECTOR CONTROL now connect to a bus.

The clock input frequency limit is derived from the figure on page 3. The minimum period for the clock pulse HIGH is 4.5 μs , plus a minimum LOW interval of 0.5 μs ; this limits the upper clock frequency to ≤ 200 kHz. Updating the operating mode of the controller IC requires only one clock period (≥ 5 μs), and the five I/O lines on the bus remain unchanged until a signal is required to change the operating mode, reverse direction, vary torque, etc.

PG001M PARALLEL-TO-SERIAL DATA CONVERTER

Integrated
Circuits

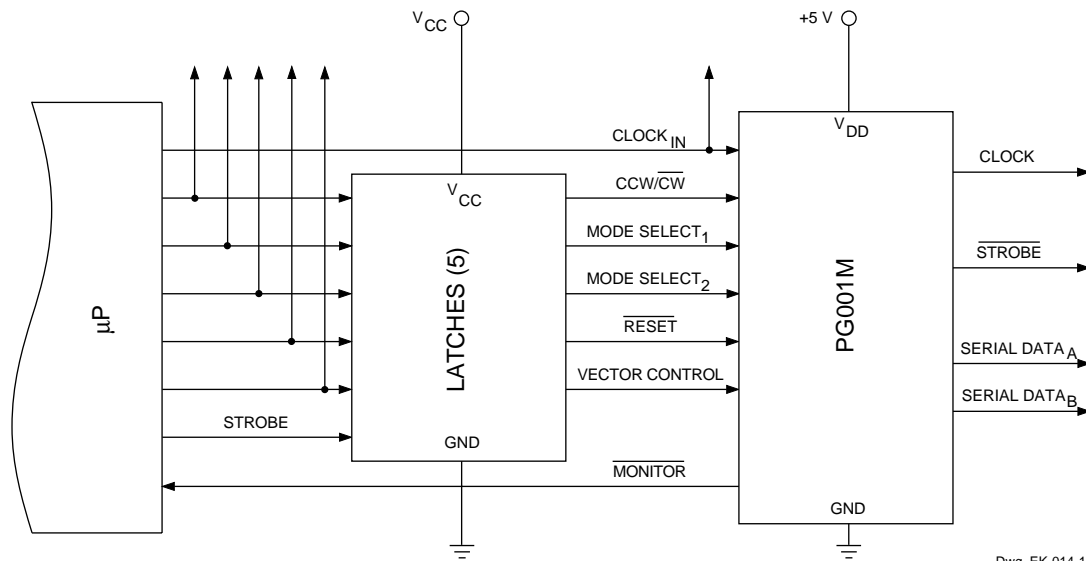
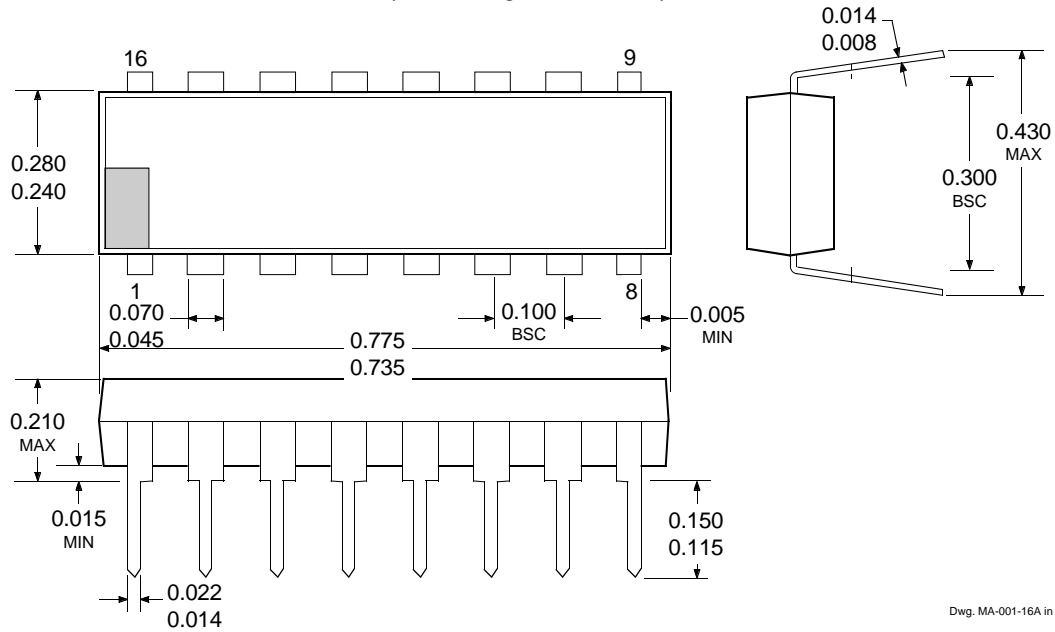

Figure 6 — A Latched Input-Bus Configuration

At start-up, resetting the counter adds only another clock interval (per figures 4 and 5). During high-speed slewing, the μP is only occupied with sending clock signals and monitoring the readback (MO). Hence, of a 200 μs interval, with a slewing rate of 5 kHz, only 5 μs is required to provide the clock input. At slower, more typical step rates, 5 μs becomes an insignificant burden on the μP controlling the stepping motor.

Other techniques to decrease and unburden the essential μP I/O lines and control logic are viable. Utilizing an 8-bit shift register (serial-to-parallel conversion) between the μP and the controller IC further reduces the I/O lines, and HCMOS logic provides serial-data entry at 20 MHz (vs <200 kHz). Such a design could further decrease the interval required to update the step-motor operation and reduce the I/O lines on the bus.

Dimensions in Inches
(controlling dimensions)



Dimensions in Millimeters
(for reference only)

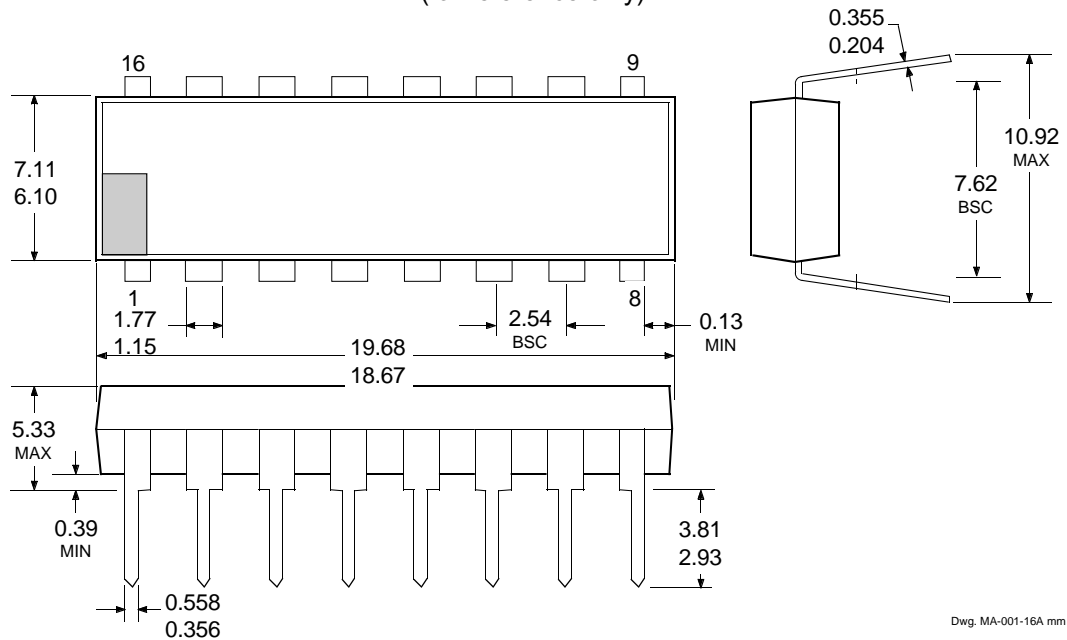

- NOTES: 1. Lead thickness is measured at seating plane or below.
 2. Lead spacing tolerance is non-cumulative.
 3. Exact body and lead configuration at vendor's option within limits shown.

PG001M
PARALLEL-TO-SERIAL
DATA CONVERTER

*Integrated
Circuits*

The products described here are manufactured in Japan by Sanken Electric Co., Ltd. for sale by Allegro MicroSystems, Inc.

Sanken Electric Co., Ltd. and Allegro MicroSystems, Inc. reserve the right to make, from time to time, such departures from the detail specifications as may be required to permit improvements in the design of their products.

The information included herein is believed to be accurate and reliable. However, Sanken Electric Co., Ltd. and Allegro MicroSystems, Inc. assume no responsibility for its use; nor for any infringements of patents or other rights of third parties which may result from its use.