

## High Voltage 3-Phase Motor Drivers

### Features and Benefits

- Built-in pre-drive IC
- MOSFET power element
- Alleviate noise generation by adjusting an internal resistor
- CMOS compatible input (5 V)
- High-side gate driver using bootstrap circuit or floating power supply
- Built-in protection circuit for controlling power supply voltage drop (UVLO on VCC)
- Overcurrent protection (OCP), overcurrent limiting (OCL), and thermal shutdown (TSD)
- Output of fault signal during operation of protection circuit
- Output current 1.5, 2, or 2.5 A
- Small SIP (SLA 24-pin)

### Packages: Power SIP

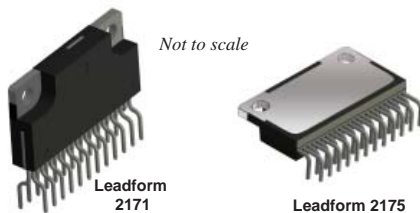

### Description

The SLA6860M inverter power module (IPM) series provides a robust, highly-integrated solution for optimally controlling 3-phase motor power inverter systems and variable speed control systems used in energy-conserving designs to drive motors of residential and commercial appliances. These ICs take 230 VAC input voltage, and up to 2.5 A (continuous) output current. They can withstand voltages of up to 500 V (MOSFET breakdown voltage).

The SLA6860M series power package includes an IC with all of the necessary power elements (six MOSFETs), pre-driver ICs (two), and bootstrap diodes (three), needed to configure the main circuit of an inverter. This enables the main circuit of the inverter to be configured with fewer external components than traditional designs.

Applications include residential white goods (home applications) and commercial appliance motor control:

- Air conditioner fan
- Small ventilation fan
- Dishwasher pump

### Functional Block Diagram

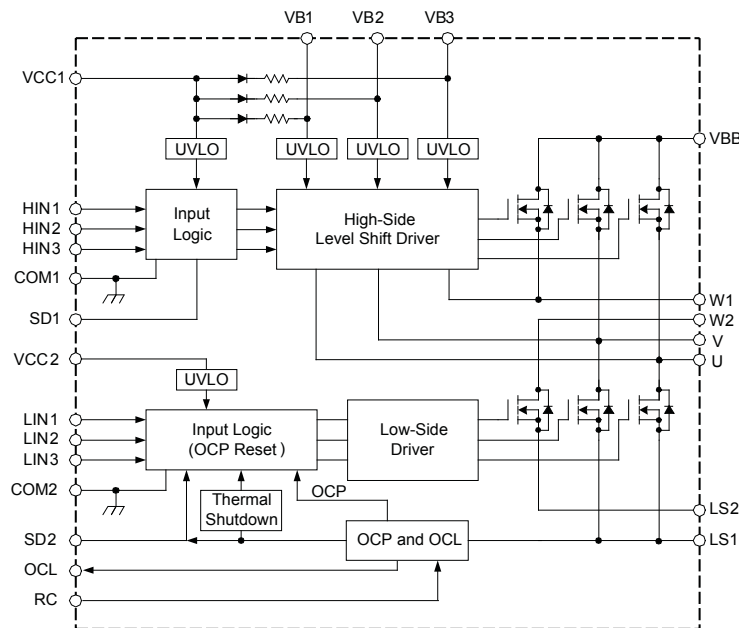

- A. SD1, SD2 terminals are used for both input and output.  
 B. SD1, SD2, and OCL terminals are open-collector output. RC terminal is open-drain output.  
 C. Blanking Time ( $t_{blank}$ ) is used in Overcurrent Limiting (OCL) and Overcurrent Protection (OCP). If the time exceeds the limit, the signal will be output (open-collector output turns on), and protection operation will start up.

Figure 1. Driver block diagram.

# SLA6860M Series

## High Voltage 3-Phase Motor Drivers

### Selection Guide

Part Number	Packing	MOSFET Breakdown Voltage, $V_{DSS(min)}$ (V)	Output Current	
			Continuous, $I_O(max)$ (A)	Pulsed, $I_{OP(max)}$ (A)
SLA6866M	18 pieces per tube	250	2	4
SLA6867M	18 pieces per tube	500	1.5	3
SLA6868M	18 pieces per tube	500	2.5	5

### Absolute Maximum Ratings, valid at $T_A = 25^\circ\text{C}$

Characteristic	Symbol	Remarks	Rating	Unit	
MOSFET Breakdown Voltage	$V_{DSS}$	SLA6866M	$V_{CC} = 15\text{ V}$ , $I_D = 100\ \mu\text{A}$ , $V_{IN} = 0\text{ V}$	250	V
		SLA6867M		500	V
		SLA6868M		500	V
Logic Supply Voltage	$V_{CC}$	Between VCC and COM	20	V	
Bootstrap Voltage	$V_{BS}$	Between VB and HS (U,V, and W phases)	20	V	
Output Current, Continuous	$I_O$	SLA6866M		2	A
		SLA6867M		1.5	A
		SLA6868M		2.5	A
Output Current, Pulsed	$I_{OP}$	SLA6866M	$PW \leq 100\ \mu\text{s}$ , duty cycle = 1%	4	A
		SLA6867M		3	A
		SLA6868M		5	A
Input Voltage	$V_{IN}$	HINx and LINx pins	-0.5 to 7	V	
Pull-up Voltage for Shutdown Pins	$V_{SDX}$	SDx pins	7	V	
Pull-up Voltage for Overcurrent Limiting Pin	$V_{OCL}$		7	V	
Allowable Power Dissipation	$P_D$	$T_C = 25^\circ\text{C}$	32.9	W	
Thermal Resistance (Junction to Case)	$R_{\theta JC}$	All elements operating	3.8	$^\circ\text{C/W}$	
Case Operating Temperature	$T_{COP}$		-20 to 100	$^\circ\text{C}$	
Junction Temperature (MOSFET)	$T_J$		150	$^\circ\text{C}$	
Storage Temperature	$T_{stg}$		-40 to 150	$^\circ\text{C}$	

All performance characteristics given are typical values for circuit or system baseline design only and are at the nominal operating voltage and an ambient temperature,  $T_A$ , of  $25^\circ\text{C}$ , unless otherwise stated.

### Recommended Operating Conditions

Characteristic	Symbol	Remarks	Min.	Typ.	Max.	Units	
Main Supply Voltage	V <sub>BB</sub>	SLA6866M	Between VBB and LS	–	–	200	V
		SLA6867M		–	–	400	V
		SLA6868M		–	–	400	V
V <sub>BB</sub> Snubber Capacitor	C <sub>SB</sub>		0.01	–	0.1	μF	
Logic Supply Voltage	V <sub>CC</sub>	Between VCC and COM	13.5	15	16.5	V	
Zener Voltage for VCCx Pins	V <sub>Z</sub>	Between VCC and COM	18	–	20	V	
Pull-up Voltage	V <sub>SDx</sub> , V <sub>OCL</sub>		4.5	5	5.5	V	
Pull-up Resistor SDx Pins	R <sub>UP2</sub>		3.3	–	10	kΩ	
Pull-up Resistor OCL Pin	R <sub>UP1</sub>		1	–	10	kΩ	
Pull-up Resistor RC Pin	R <sub>R</sub>		33	–	390	kΩ	
Capacitor SDX Pins	C <sub>SDX</sub>		1	–	10	nF	
Capacitor RC Pin	C <sub>C</sub>		1	–	4.7	nF	
Dead Time	t <sub>dead</sub>	T <sub>J</sub> = –20°C to 150°C	1.5	–	–	μs	
Minimum Input Pulse Width	I <sub>INMIN(on)</sub>	T <sub>J</sub> = –20°C to 150°C	0.5	–	–	μs	
	I <sub>INMIN(off)</sub>	T <sub>J</sub> = –20°C to 150°C	0.5	–	–	μs	
Switching Frequency	f <sub>PWM</sub>		–	–	20	kHz	
Junction Temperature	T <sub>J</sub>		–	–	125	°C	

# SLA6860M Series

## High Voltage 3-Phase Motor Drivers

### Typical Application Diagram

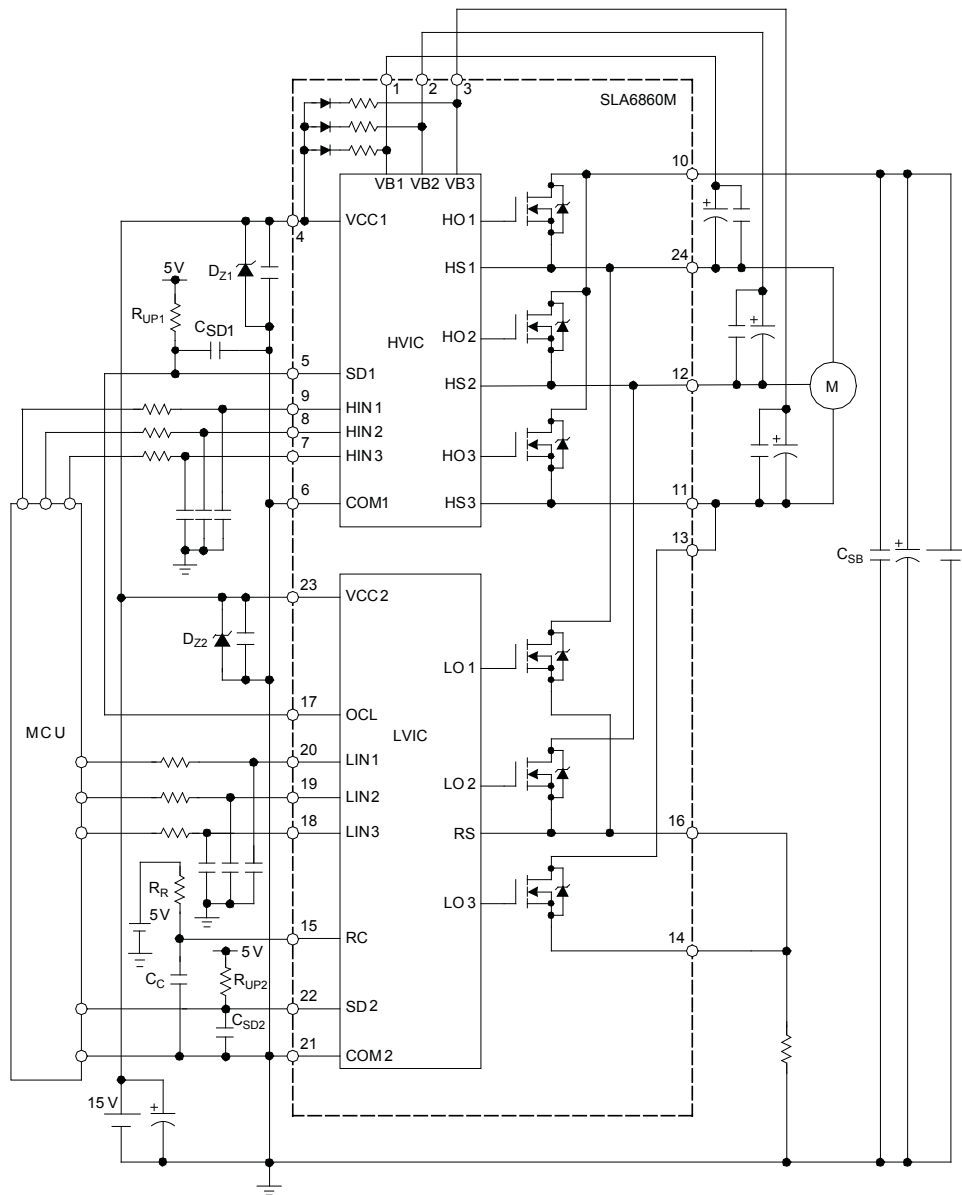

#### NOTE:

- The external electrolytic capacitors should be placed as close to the IC as possible, in order to avoid malfunctions from external noise interference. Put a ceramic capacitor in parallel with the electrolytic capacitor if further reduction of noise susceptibility is necessary.

# SLA6860M Series

## High Voltage 3-Phase Motor Drivers

### ELECTRICAL CHARACTERISTICS, valid at $T_A=25^\circ\text{C}$ , unless otherwise noted

Characteristics	Symbol	Conditions	Min	Typ	Max	Units	
Logic Supply Current	$I_{CC}$	$V_{CC} = 15\text{ V}$ , $T_C = -20^\circ\text{C}$ to $125^\circ\text{C}$	–	4.2	7	mA	
Bootstrap Supply Current	$I_{BX}$	$V_{BX} = 15\text{ V}$ , $V_{HIN} = 5\text{ V}$	–	135	380	$\mu\text{A}$	
Input Voltage	$V_{IH}$	$V_{CC} = 15\text{ V}$	–	2.9	3.4	V	
	$V_{IL}$	$V_{CC} = 15\text{ V}$	1.6	2.1	–	V	
Input Voltage Hysteresis	$V_{Ihys}$	$V_{CC} = 15\text{ V}$	–	0.8	–	V	
Input Current	$I_{IN}$	$V_{IN} = 5\text{ V}$	–	230	500	$\mu\text{A}$	
Undervoltage Lock Out	$V_{UVHL}$	High side, between $V_{BX}$ and U, V, or W	9.0	10.0	11.0	V	
	$V_{UVHH}$		9.5	10.5	11.5	V	
	$V_{UVHhys}$	High side, hysteresis	–	0.5	–	V	
	$V_{UVLL}$	Low side, between $V_{CC2}$ and COM2	10.0	11.0	12.0	V	
	$V_{UVLH}$		10.5	11.5	12.5	V	
	$V_{UVLhys}$	Low side, hysteresis	–	0.5	–	V	
SDx and OCL Output Voltage	$V_{SDX(on)}$ , $V_{OCL}$	$V_{SDX} = V_{OCL} = 5\text{ V}$ , $R_{UPX} = 3.3\text{ k}\Omega$	–	–	0.6	V	
Overtemperature Detection Threshold Temperature (Activation and Deactivation)	$T_{DH}$	$V_{CC} = 15\text{ V}$ , high-side and low side	120	135	150	$^\circ\text{C}$	
	$T_{DL}$		100	115	130	$^\circ\text{C}$	
	$T_{Dhys}$		–	20	–	$^\circ\text{C}$	
Overcurrent Protection Trip Voltage	$V_{TRIP}$	$V_{CC} = 15\text{ V}$	0.9	1.0	1.1	V	
Overcurrent Limit Reference Voltage	$V_{LIM}$	$V_{CC} = 15\text{ V}$	0.5035	0.53	0.5565	V	
Overcurrent Protection Hold Time	$t_p$	$V_{RC} = 5\text{ V}$ , $R_R = 360\text{ k}\Omega$ , $C_C = 0.0047\text{ }\mu\text{F}$	–	2.0	–	ms	
Blanking Time	$t_{blank}$	$V_{CC} = 15\text{ V}$	1.4	2.0	2.6	$\mu\text{s}$	
Bootstrap Diode Leakage Current	$I_{LBD}$	SLA6866M $V_R = 250\text{ V}$	–	–	10	$\mu\text{A}$	
		SLA6867M $V_R = 500\text{ V}$	–	–	10	$\mu\text{A}$	
		SLA6868M $V_R = 500\text{ V}$	–	–	10	$\mu\text{A}$	
Bootstrap Diode Forward Voltage	$V_{FBD}$	SLA6866M $I_F = 0.05\text{ A}$	–	1.1	1.3	V	
		SLA6867M $I_F = 0.05\text{ A}$	–	1.1	1.3	V	
		SLA6868M $I_F = 0.05\text{ A}$	–	1.1	1.3	V	
Bootstrap Diode Recovery Time	$t_{rtb}$	$I_F / I_{RP} = 100\text{ mA} / 100\text{ mA}$	–	70	–	ns	
Bootstrap Diode Series Resistor	$R_{BD}$		168	210	252	$\Omega$	
MOSFET Breakdown Voltage	$V_{DSS}$	SLA6866M	$V_{CC} = 15\text{ V}$ , $I_D = 100\text{ }\mu\text{A}$ , $V_{IN} = 0\text{ V}$	250	–	–	V
		SLA6867M		500	–	–	V
		SLA6868M		500	–	–	V

Continued on the next page...

# SLA6860M Series

## High Voltage 3-Phase Motor Drivers

ELECTRICAL CHARACTERISTICS (continued), valid at  $T_A=25^{\circ}\text{C}$ , unless otherwise noted

Characteristics	Symbol	Conditions		Min	Typ	Max	Units
MOSFET Leakage Current	$I_{DSS}$	SLA6866M	$V_{CC} = 15\text{ V}, V_{DS} = 250\text{ V}, V_{IN} = 0\text{ V}$	–	–	100	$\mu\text{A}$
		SLA6867M	$V_{CC} = 15\text{ V}, V_{DS} = 500\text{ V}, V_{IN} = 0\text{ V}$	–	–	100	$\mu\text{A}$
		SLA6868M	$V_{CC} = 15\text{ V}, V_{DS} = 500\text{ V}, V_{IN} = 0\text{ V}$	–	–	100	$\mu\text{A}$
MOSFET On State Resistance	$R_{DS(on)}$	SLA6866M	$V_{CC} = 15\text{ V}, I_D = 1\text{ A}, V_{IN} = 5\text{ V}$	–	1.4	1.8	$\Omega$
		SLA6867M	$V_{CC} = 15\text{ V}, I_D = 1\text{ A}, V_{IN} = 5\text{ V}$	–	3.2	4.0	$\Omega$
		SLA6868M	$V_{CC} = 15\text{ V}, I_D = 1.5\text{ A}, V_{IN} = 5\text{ V}$	–	2.0	2.4	$\Omega$
MOSFET Diode Forward Voltage	$V_{SDF}$	SLA6866M	$V_{CC} = 15\text{ V}, I_{SD} = 1\text{ A}, V_{IN} = 0\text{ V}$	–	1.1	1.5	V
		SLA6867M	$V_{CC} = 15\text{ V}, I_{SD} = 1\text{ A}, V_{IN} = 0\text{ V}$	–	1.1	1.5	V
		SLA6868M	$V_{CC} = 15\text{ V}, I_{SD} = 1.5\text{ A}, V_{IN} = 0\text{ V}$	–	1.1	1.5	V

# SLA6860M Series

## High Voltage 3-Phase Motor Drivers

SLA6866M SWITCHING CHARACTERISTICS, valid at  $T_A=25^\circ\text{C}$ , unless otherwise noted

Characteristics	Symbol	Conditions	Min	Typ	Max	Units
Switching Time, High Side	$t_{dH(on)}$	$V_{BB} = 150\text{ V}, V_{CC} = 15\text{ V}, I_D = 2\text{ A}, 0\text{ V} \leq V_{IN} \leq 5\text{ V}$	-	660	-	ns
	$t_{rH}$		-	25	-	ns
	$t_{rrH}$		-	690	-	ns
	$t_{dH(off)}$		-	630	-	ns
	$t_{fH}$		-	10	-	ns
Switching Time, Low Side	$t_{dL(on)}$	$V_{BB} = 150\text{ V}, V_{CC} = 15\text{ V}, I_D = 2\text{ A}, 0\text{ V} \leq V_{IN} \leq 5\text{ V}$	-	580	-	ns
	$t_{rL}$		-	50	-	ns
	$t_{rrL}$		-	95	-	ns
	$t_{dL(off)}$		-	540	-	ns
	$t_{fL}$		-	15	-	ns

SLA6867M SWITCHING CHARACTERISTICS, valid at  $T_A=25^\circ\text{C}$ , unless otherwise noted

Characteristics	Symbol	Conditions	Min	Typ	Max	Units
Switching Time, High Side	$t_{dH(on)}$	$V_{BB} = 300\text{ V}, V_{CC} = 15\text{ V}, I_D = 1.5\text{ A}, 0\text{ V} \leq V_{IN} \leq 5\text{ V}$	-	720	-	ns
	$t_{rH}$		-	40	-	ns
	$t_{rrH}$		-	110	-	ns
	$t_{dH(off)}$		-	670	-	ns
	$t_{fH}$		-	20	-	ns
Switching Time, Low Side	$t_{dL(on)}$	$V_{BB} = 300\text{ V}, V_{CC} = 15\text{ V}, I_D = 1.5\text{ A}, 0\text{ V} \leq V_{IN} \leq 5\text{ V}$	-	600	-	ns
	$t_{rL}$		-	40	-	ns
	$t_{rrL}$		-	120	-	ns
	$t_{dL(off)}$		-	555	-	ns
	$t_{fL}$		-	20	-	ns

SLA6868M SWITCHING CHARACTERISTICS, valid at  $T_A=25^\circ\text{C}$ , unless otherwise noted

Characteristics	Symbol	Conditions	Min	Typ	Max	Units
Switching Time, High Side	$t_{dH(on)}$	$V_{BB} = 300\text{ V}, V_{CC} = 15\text{ V}, I_D = 2.5\text{ A}, 0\text{ V} \leq V_{IN} \leq 5\text{ V}$	-	790	-	ns
	$t_{rH}$		-	60	-	ns
	$t_{rrH}$		-	115	-	ns
	$t_{dH(off)}$		-	725	-	ns
	$t_{fH}$		-	20	-	ns
Switching Time, Low Side	$t_{dL(on)}$	$V_{BB} = 300\text{ V}, V_{CC} = 15\text{ V}, I_D = 2.5\text{ A}, 0\text{ V} \leq V_{IN} \leq 5\text{ V}$	-	680	-	ns
	$t_{rL}$		-	70	-	ns
	$t_{rrL}$		-	120	-	ns
	$t_{dL(off)}$		-	605	-	ns
	$t_{fL}$		-	20	-	ns

### OCP Timing Diagram

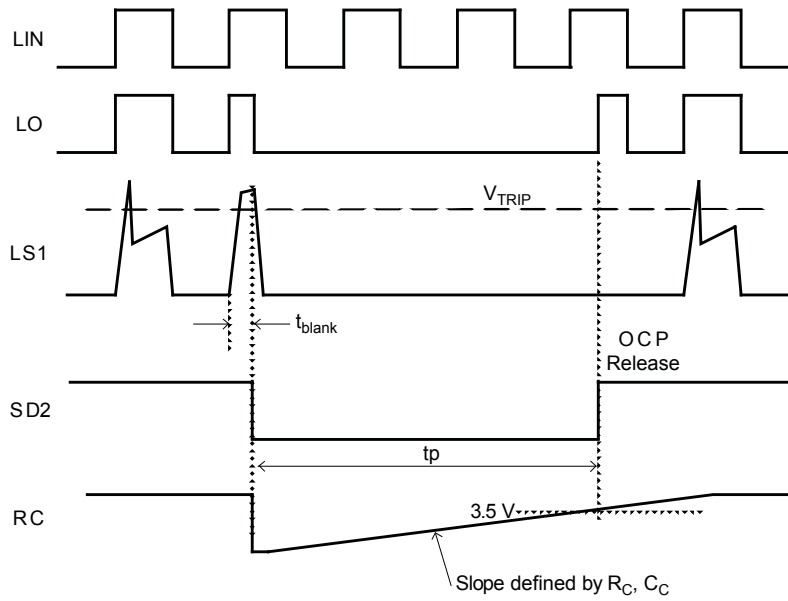

### Low-Side TSD Timing Diagram

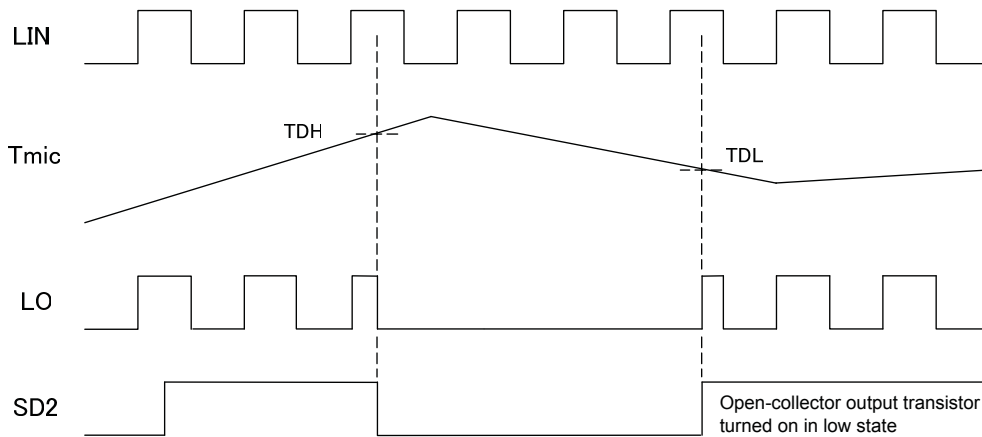

### High-Side UVLO Timing Diagram

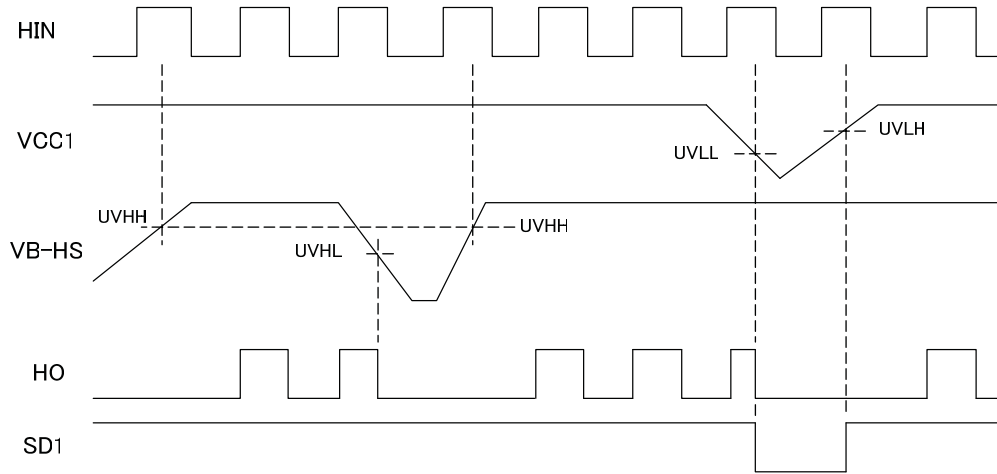

### Low-Side UVLO Timing Diagram

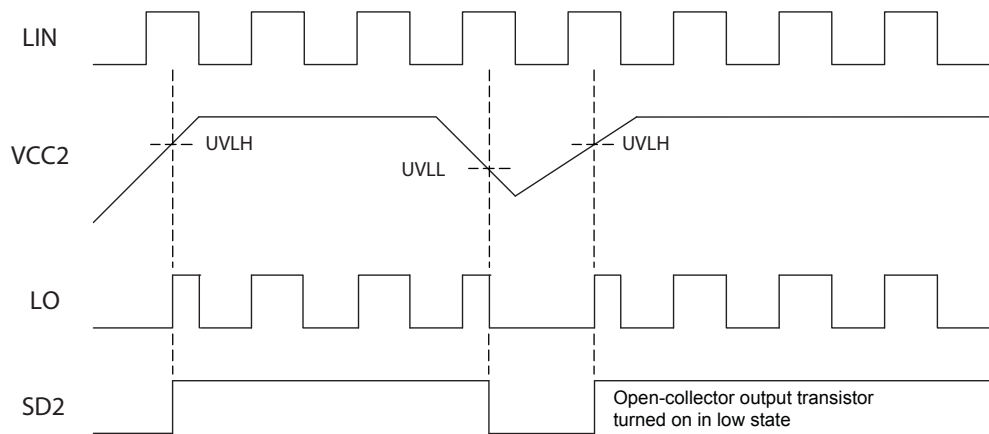

## OCL Timing Diagram

OCL and SD1 pins connected externally

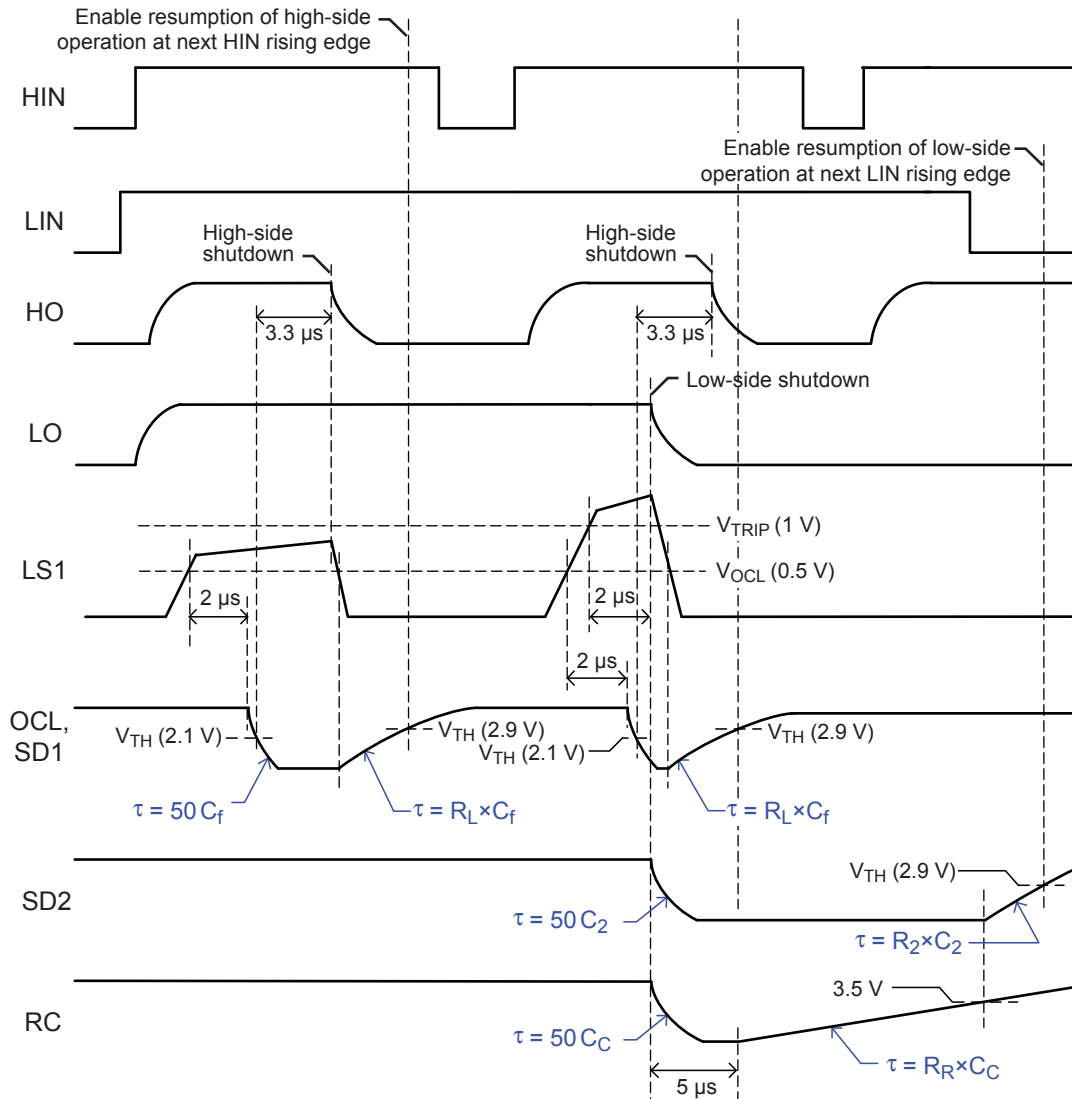

### Pin-out Diagram

Leadform 2171

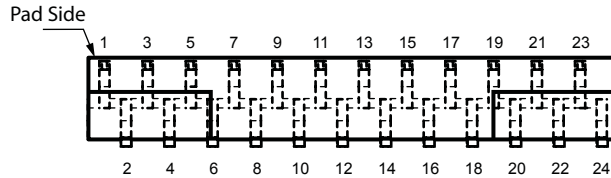

Leadform 2175

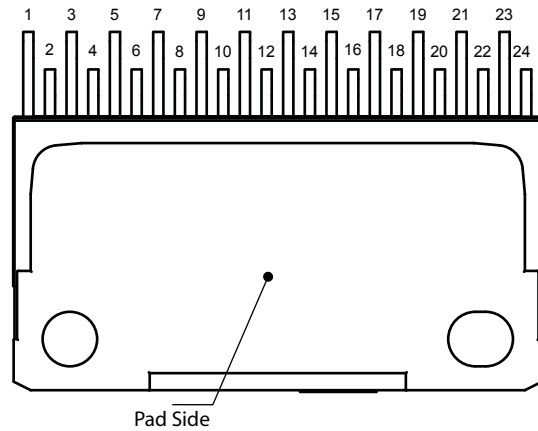

### Terminal List Table

Number	Name	Function
1	VB1	High side bootstrap terminal (U phase)
2	VB2	High side bootstrap terminal (V phase)
3	VB3	High side bootstrap terminal (W phase)
4	VCC1	High side logic supply voltage
5	SD1	High side shutdown input and UVLO fault signal output
6	COM1	High side logic GND terminal
7	HIN3	High side input terminal (W phase)
8	HIN2	High side input terminal (V phase)
9	HIN1	High side input terminal (U phase)
10	VBB	Main supply voltage
11	W1	Output of W phase (connect to W2 externally)
12	V	Output of V phase
13	W2	Output of W phase (connect to W1 externally)
14	LS2	Low side source terminal (connect to LS1 externally)
15	RC	Overcurrent protection hold time adjustment input terminal
16	LS1	Low side source terminal (connect to LS2 externally)
17	OCL	Output for overcurrent limiting
18	LIN3	Low side input terminal (W phase)
19	LIN2	Low side input terminal (V phase)
20	LIN1	Low side input terminal (U phase)
21	COM2	Low side GND terminal
22	SD2	Low side shutdown input and overtemperature, overcurrent, and UVLO fault signals output
23	VCC2	Low side logic supply voltage
24	U	Output of U phase

## Package Outline Drawing Leadform 2171

Dual rows, 24 alternating pins; vertical case mounting; pin #1 on tab side

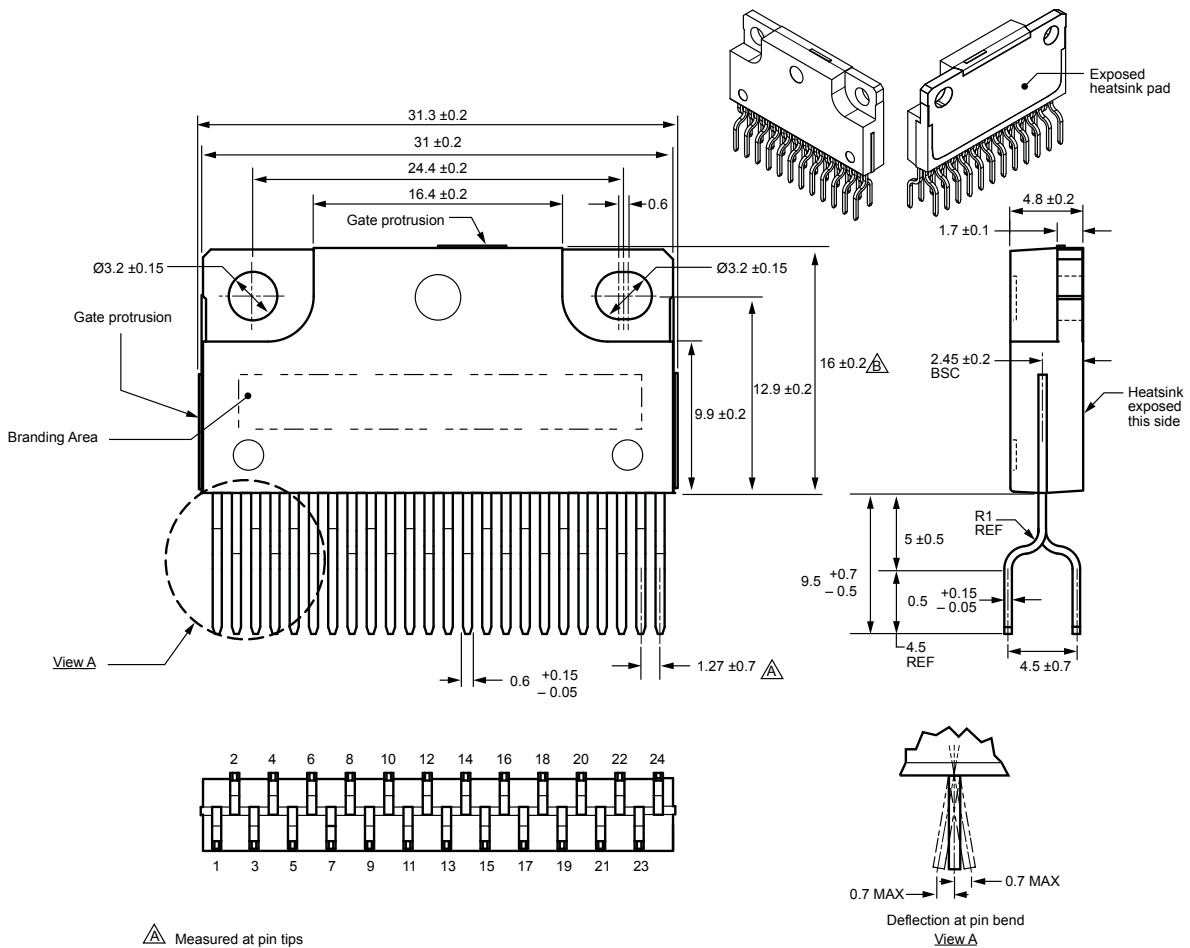

Leadform: 2171  
 Terminal core material: Cu  
 Terminal plating: Ni  
 Recommended attachment: Solder dip (Sn-Ag-Cu)

Dimensions in millimeters

Branding codes (exact appearance at manufacturer discretion):  
 1st line, type: SLA686xM

2nd line, lot: YMDD#  
 Where: Y is the last digit of the year of manufacture  
 M is the month (1 to 9, O, N, D)  
 DD is the date  
 # is the tracking letter



Leadframe plating Pb-free. Device composition complies with the RoHS directive.

## Package Outline Drawing Leadform 2175

Dual rows, 24 alternating pins; pins bent 90° for horizontal case mounting; pin #1 in outer row

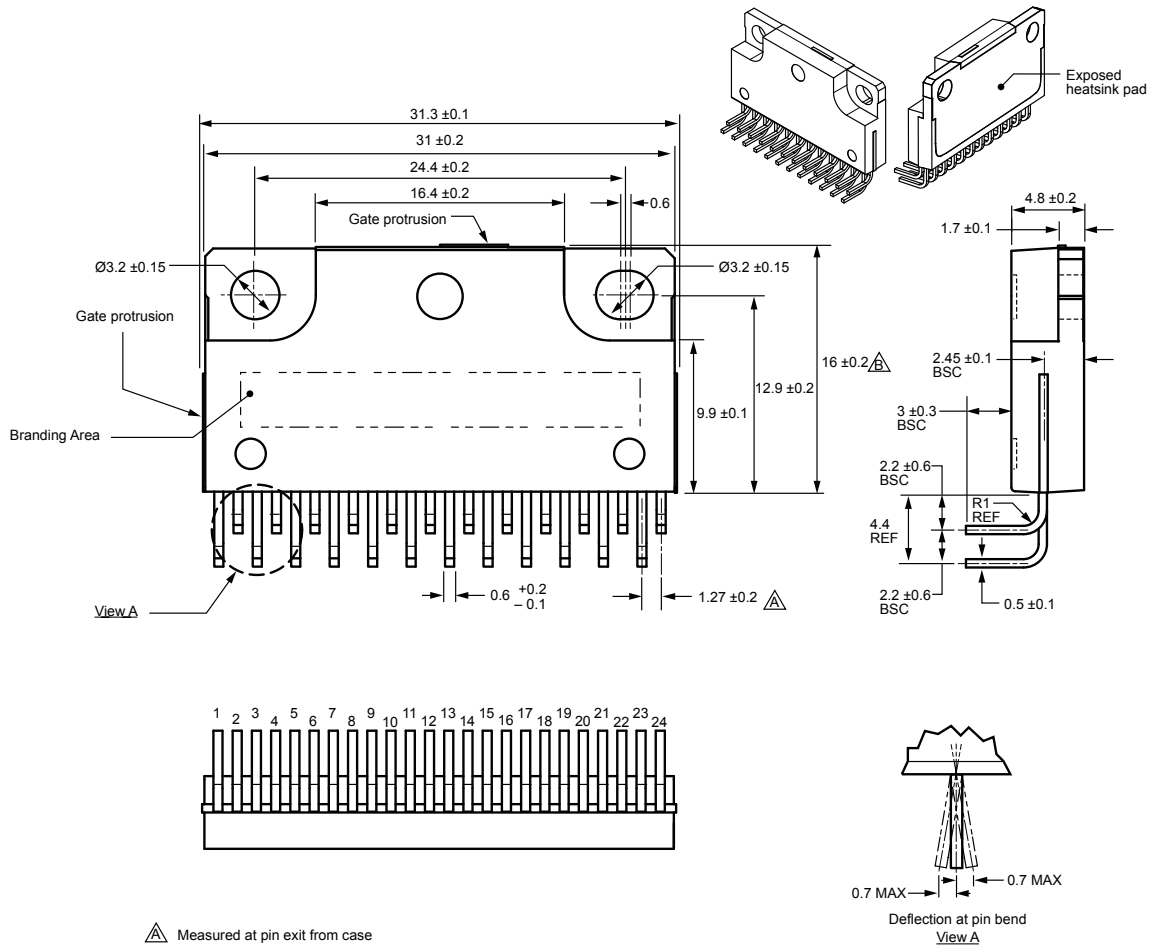

△ Measured at pin exit from case  
△ To case top

Leadform: 2175  
Terminal core material: Cu  
Terminal plating: Ni  
Recommended attachment: Solder dip (Sn-Ag-Cu)

Dimensions in millimeters

Branding codes (exact appearance at manufacturer discretion):  
1st line, type: SLA686xM

2nd line, lot: YMDD#  
Where: Y is the last digit of the year of manufacture  
M is the month (1 to 9, O, N, D)  
DD is the date  
# is the tracking letter



Leadframe plating Pb-free. Device composition complies with the RoHS directive.

**Packing Specification**

**Leadform 2171**

Dimensions in millimeters

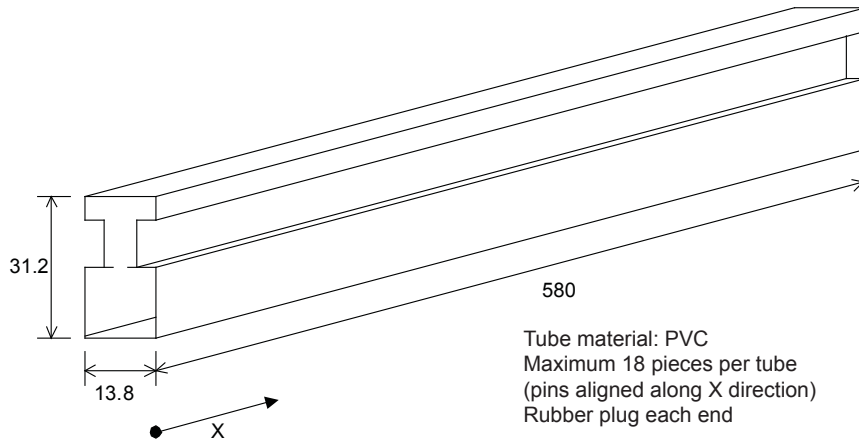

Tube material: PVC  
Maximum 18 pieces per tube  
(pins aligned along X direction)  
Rubber plug each end

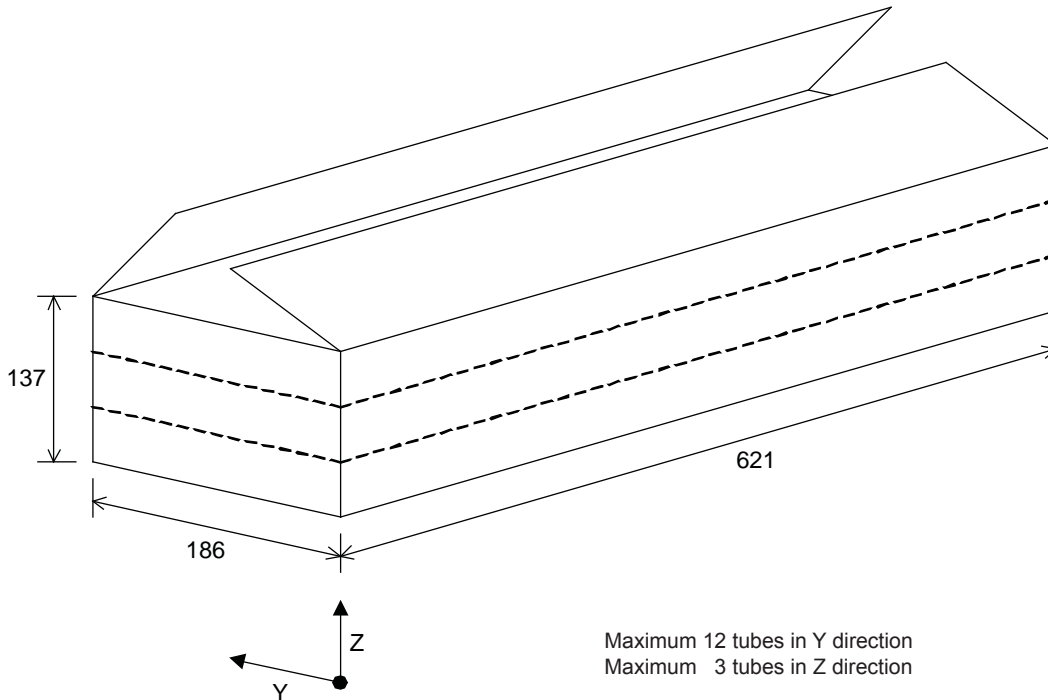

Maximum 12 tubes in Y direction  
Maximum 3 tubes in Z direction

Maximum pieces per carton:

18 pieces per tube  
12 tubes per layer  
x 3 layers of tubes  
648 pieces per carton

**Packing Specification**

**Leadform 2175**

Dimensions in millimeters

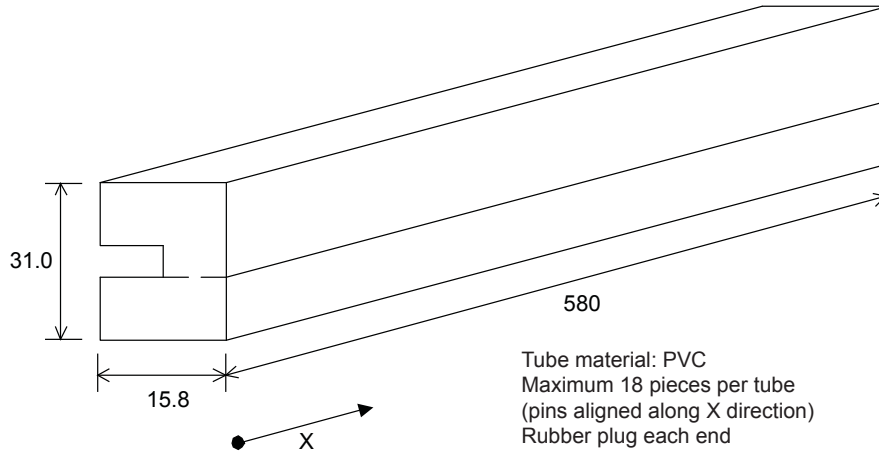

Tube material: PVC  
Maximum 18 pieces per tube  
(pins aligned along X direction)  
Rubber plug each end

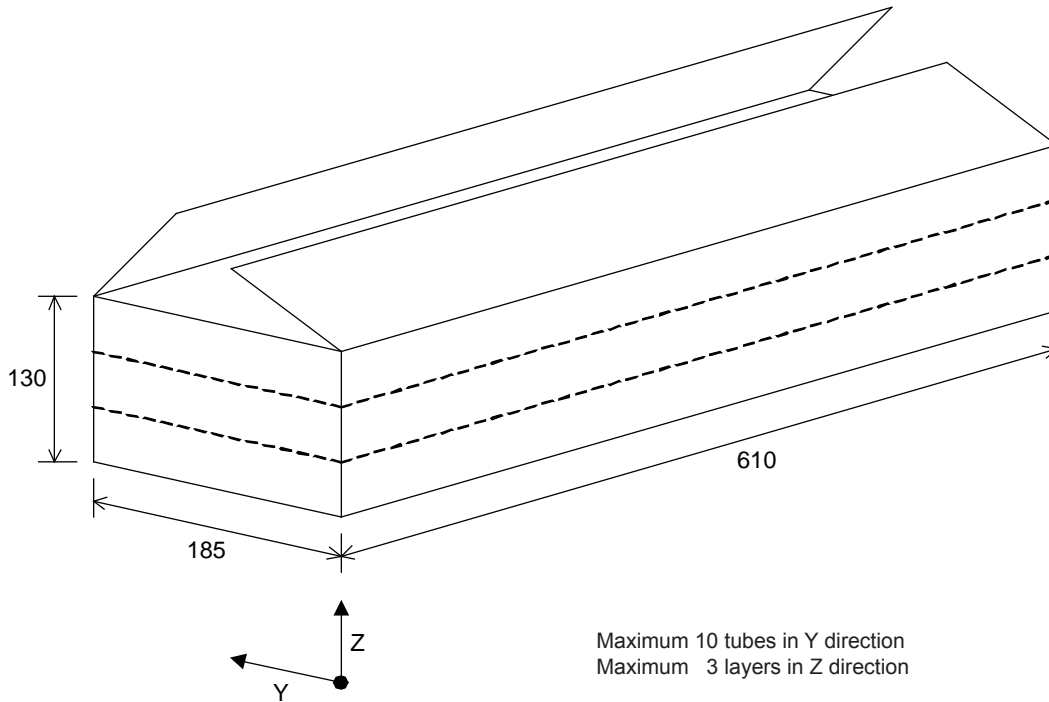

Maximum 10 tubes in Y direction  
Maximum 3 layers in Z direction

Maximum pieces per carton:  
18 pieces per tube  
10 tubes per layer  
x 3 layers of tubes  
540 pieces per carton

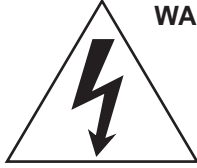

**WARNING** — These devices are designed to be operated at lethal voltages and energy levels. Circuit designs that embody these components must conform with applicable safety requirements. Precautions must be taken to prevent accidental contact with power-line potentials. Do not connect grounded test equipment.

The use of an isolation transformer is recommended during circuit development and breadboarding.

Because reliability can be affected adversely by improper storage environments and handling methods, please observe the following cautions.

#### Cautions for Storage

- Ensure that storage conditions comply with the standard temperature (5°C to 35°C) and the standard relative humidity (around 40 to 75%); avoid storage locations that experience extreme changes in temperature or humidity.
- Avoid locations where dust or harmful gases are present and avoid direct sunlight.
- Reinspect for rust on leads and solderability of products that have been stored for a long time.

#### Cautions for Testing and Handling

When tests are carried out during inspection testing and other standard test periods, protect the products from power surges from the testing device, shorts between adjacent products, and shorts to the heatsink.

#### Remarks About Using Silicone Grease with a Heatsink

- When silicone grease is used in mounting this product on a heatsink, it shall be applied evenly and thinly. If more silicone grease than required is applied, it may produce stress.
- Volatile-type silicone greases may permeate the product and produce cracks after long periods of time, resulting in reduced heat radiation effect, and possibly shortening the lifetime of the product.
- Our recommended silicone greases for heat radiation purposes, which will not cause any adverse effect on the product life, are indicated below:

Type	Suppliers
G746	Shin-Etsu Chemical Co., Ltd.
YG6260	Momentive Performance Materials, Inc.
SC102	Dow Corning Toray Silicone Co., Ltd.

#### Heatsink Mounting Method

**Torque When Tightening Mounting Screws.** The recommended tightening torque for this product package type is: 58.8 to 78.4 N•cm (6.0 to 8.0 kgf•cm).

#### Soldering

- When soldering the products, please be sure to minimize the working time, within the following limits:
  - 260±5°C 10 s
  - 380±5°C 5 s
- Soldering iron should be at a distance of at least 1.5 mm from the body of the products

#### Electrostatic Discharge

- When handling the products, operator must be grounded. Grounded wrist straps worn should have at least 1 MΩ of resistance to ground to prevent shock hazard.
- Workbenches where the products are handled should be grounded and be provided with conductive table and floor mats.
- When using measuring equipment such as a curve tracer, the equipment should be grounded.
- When soldering the products, the head of soldering irons or the solder bath must be grounded in order to prevent leak voltages generated by them from being applied to the products.
- The products should always be stored and transported in our shipping containers or conductive containers, or be wrapped in aluminum foil.

---

*The products described herein are manufactured in Japan by Sanken Electric Co., Ltd. for sale by Allegro MicroSystems, Inc.*

*Sanken and Allegro reserve the right to make, from time to time, such departures from the detail specifications as may be required to permit improvements in the performance, reliability, or manufacturability of its products. Therefore, the user is cautioned to verify that the information in this publication is current before placing any order.*

*When using the products described herein, the applicability and suitability of such products for the intended purpose shall be reviewed at the users responsibility.*

*Although Sanken undertakes to enhance the quality and reliability of its products, the occurrence of failure and defect of semiconductor products at a certain rate is inevitable.*

*Users of Sanken products are requested to take, at their own risk, preventative measures including safety design of the equipment or systems against any possible injury, death, fires or damages to society due to device failure or malfunction.*

*Sanken products listed in this publication are designed and intended for use as components in general-purpose electronic equipment or apparatus (home appliances, office equipment, telecommunication equipment, measuring equipment, etc.). Their use in any application requiring radiation hardness assurance (e.g., aerospace equipment) is not supported.*

*When considering the use of Sanken products in applications where higher reliability is required (transportation equipment and its control systems or equipment, fire- or burglar-alarm systems, various safety devices, etc.), contact a company sales representative to discuss and obtain written confirmation of your specifications.*

*The use of Sanken products without the written consent of Sanken in applications where extremely high reliability is required (aerospace equipment, nuclear power-control stations, life-support systems, etc.) is strictly prohibited.*

*The information included herein is believed to be accurate and reliable. Application and operation examples described in this publication are given for reference only and Sanken and Allegro assume no responsibility for any infringement of industrial property rights, intellectual property rights, or any other rights of Sanken or Allegro or any third party that may result from its use.*

*The contents in this document must not be transcribed or copied without Sanken's written consent.*

### Worldwide Contacts

#### Asia-Pacific

##### China

###### **Sanken Electric Hong Kong Co., Ltd.**

Suite 1026, Ocean Centre  
Canton Road, Tsimshatsui  
Kowloon, Hong Kong  
Tel: 852-2735-5262, Fax: 852-2735-5494

###### **Sanken Electric (Shanghai) Co., Ltd.**

Room 3202, Maxdo Centre  
Xingyi Road 8, Changning District  
Shanghai, China  
Tel: 86-21-5208-1177, Fax: 86-21-5208-1757

###### **Sanken Electric (Shanghai) Co., Ltd.**

**Shenzhen Office**  
Room 1013, Xinhua Insurance Building  
Mintian Road, Futian District  
Shenzhen City, Guangdong, China  
Tel: 86-755-3391-9356/9358, Fax: 86-755-3391-9368

###### **Taiwan Sanken Electric Co., Ltd.**

Room 1801, 18th Floor  
88 Jung Shiau East Road, Sec. 2  
Taipei 100, Taiwan R.O.C.  
Tel: 886-2-2356-8161, Fax: 886-2-2356-8261

##### Japan

###### **Sanken Electric Co., Ltd. Overseas Sales Headquarters**

Metropolitan Plaza Building  
1-11-1 Nishi-Ikebukuro, Toshima-ku  
Tokyo 171-0021, Japan  
Tel: 81-3-3986-6164, Fax: 81-3-3986-8637

##### Korea

###### **Sanken Electric Korea Co., Ltd.**

Samsung Life Yeouido Building 16F  
23-10, Yeouido-Dong, Yeongdeungpo-gu  
Seoul 150-734, Korea  
Tel: 82-2-714-3700, Fax: 82-2-3272-2145

##### Singapore

###### **Sanken Electric Singapore Pte. Ltd.**

152 Beach Road, #10-06 The Gateway East  
Singapore 189721  
Tel: 65-6291-4755, Fax: 65-6297-1744

#### Europe

###### **Sanken Power Systems (UK) Limited**

Pencoed Technology Park  
Pencoed, Bridgend CF35 5HY, United Kingdom  
Tel: 44-1656-869-100, Fax: 44-1656-869-162

#### North America

##### United States

###### **Allegro MicroSystems, Inc.**

115 Northeast Cutoff  
Worcester, Massachusetts 01606, U.S.A.  
Tel: 1-508-853-5000, Fax: 1-508-853-7895

###### **Allegro MicroSystems, Inc.**

14 Hughes Street, Suite B105  
Irvine, California 92618, U.S.A.  
Tel: 1-949-460-2003, Fax: 1-949-460-7837