

Chopper Stabilized, Precision Hall Effect Latches for Consumer and Industrial Applications

Features and Benefits

- Symmetrical switchpoints
- Resistant to physical stress
- Superior temperature stability
- Output short-circuit protection
- Operation from unregulated supply
- Reverse battery protection
- Solid-state reliability
- Small package size

Packages:



3-pin SOT23W (suffix LH)



3-pin SIP (suffix UA)

Not to scale

Description

The A3290 and A3291 Hall effect latches are extremely temperature-stable and stress-resistant sensor ICs, especially suited for operation over extended temperature ranges (up to 125°C). Superior high-temperature performance is made possible through Dynamic Offset Cancellation, which reduces the residual offset voltage normally caused by device package overmolding, temperature dependencies, and thermal stress. The two devices are identical except for their magnetic switchpoints. They are not intended for automotive applications.

Both devices include, on a single silicon chip, a voltage regulator, a Hall-voltage generator, a small-signal amplifier, chopper stabilization, a Schmitt trigger, and a short-circuit protected open-drain output to sink up to 25 mA. A south polarity magnetic field of sufficient strength is required to turn the output on. A north polarity field of sufficient strength is necessary to turn the output off. An onboard regulator permits operation with supply voltages in the range of 4.2 to 24 V.

Two package styles provide a magnetically optimized package for most applications. Type LH is a miniature SOT23W low-profile surface-mount package, and type UA is a three-pin ultramini SIP for through-hole mounting. Both packages are lead (Pb) free with 100% matte tin leadframe plating.

Functional Block Diagram

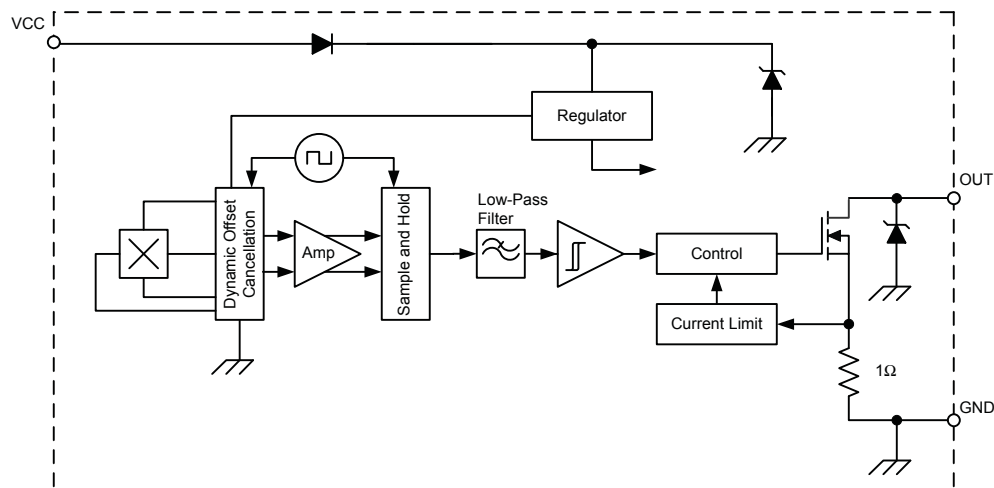

A3290 and A3291

Chopper Stabilized, Precision Hall Effect Latches for Consumer and Industrial Applications

Selection Guide

Part Number	Packing ¹	Package Type	Magnetic Switchpoints*	
			Operate, B _{OP} (G)	Release, B _{RP} (G)
A3290KLHLT-T	3000 pieces per 7-in. reel	Surface mount SOT23W	5 to 50	-50 to -5
A3290KUA-T	500 pieces per bulk bag	Through hole ultramini SIP		
A3291KLHLT-T	3000 pieces per 7-in. reel	Surface mount SOT23W	10 to 100	-100 to -10
A3291KUA-T	500 pieces per bulk bag	Through hole ultramini SIP		

*Algebraic convention used: (+) south polarity, (-) north polarity.



Absolute Maximum Ratings

Characteristic	Symbol	Notes	Rating	Units
Supply Voltage	V _{CC}		26.5	V
Reverse Battery Voltage	V _{RCC}		-30	V
Output Off Voltage	V _{OUT}		26	V
Continuous Output Current	I _{OUT}	Device provides internal current limiting to help protect itself from output short circuits	25	mA
Reverse Output Current	I _{ROUT}		-50	mA
Magnetic Flux Density	B		Unlimited	G
Operating Ambient Temperature	T _A	Range K	-40 to 125	°C
Maximum Junction Temperature	T _{J(max)}		165	°C
Storage Temperature	T _{stg}		-65 to 170	°C

Pin-out Diagrams

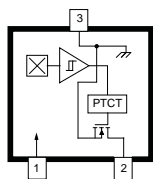

Package LH

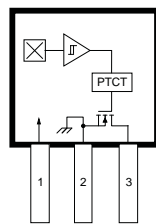

Package UA

Terminal List

Name	Number		Function
	LH	UA	
VCC	1	1	Power supply
OUT	2	3	Output
GND	3	2	Ground

ELECTRICAL CHARACTERISTICS over operating temperature range, unless otherwise noted

Characteristic	Symbol	Test Conditions	Min.	Typ. ¹	Max	Units
Supply Voltage Range ²	V_{CC}	Operating, $T_J < 165^\circ\text{C}$	4.2	–	24	V
Output Leakage Current	I_{OFF}	$V_{OUT} = 24\text{ V}$, $B < B_{RP}$	–	–	10	μA
Output Saturation Voltage	$V_{OUT(SAT)}$	$I_{OUT} = 20\text{ mA}$, $B > B_{OP}$	–	185	500	mV
Output Current Limit	I_{ON}	$B > B_{OP}$	30	–	60	mA
Power-On Time	t_{PO}	$V_{CC} > 4.2\text{ V}$	–	–	50	μs
Chopping Frequency	f_C		–	800	–	kHz
Output Rise Time	t_R	$R_{LOAD} = 820\ \Omega$, $C_{LOAD} = 20\text{ pF}$	–	0.2	2.0	μs
Output Fall Time	t_F	$R_{LOAD} = 820\ \Omega$, $C_{LOAD} = 20\text{ pF}$	–	0.1	2.0	μs
Supply Current	I_{CC}	$B < B_{RP}$, $V_{CC} = 12\text{ V}$	–	3.0	8.0	mA
		$B > B_{OP}$, $V_{CC} = 12\text{ V}$	–	4.0	8.0	mA
Reverse Battery Current	I_{RCC}	$V_{RCC} = -30\text{ V}$	–	–	-5.0	mA
Zener Voltage	$V_Z + V_D$	$I_{CC} = 15\text{ mA}$, $T_A = 25^\circ\text{C}$	28	–	–	V
Zener Impedance	$Z_Z + Z_D$	$I_{CC} = 15\text{ mA}$, $T_A = 25^\circ\text{C}$	–	50	–	Ω

¹Typical data at $T_A = 25^\circ\text{C}$, 12 V.

²Maximum V_{CC} must be derated for power dissipation and junction temperature. See application information.

MAGNETIC CHARACTERISTICS¹ over V_{CC} range, unless otherwise noted

Characteristic	Symbol	Test Conditions	Min.	Max.	Units	
Operate Point ²	B_{OP}	A3290	$T_A = 25^\circ\text{C}$ and $T_{A(max)}$	5	50	G
			$T_A = -40^\circ\text{C}$	5	50	G
		A3291	$T_A = 25^\circ\text{C}$ and $T_{A(max)}$	10	100	G
			$T_A = -40^\circ\text{C}$	10	100	G
Release Point ³	B_{RP}	A3290	$T_A = 25^\circ\text{C}$ and $T_{A(max)}$	-50	-5	G
			$T_A = -40^\circ\text{C}$	-50	-5	G
		A3291	$T_A = 25^\circ\text{C}$ and $T_{A(max)}$	-100	-10	G
			$T_A = -40^\circ\text{C}$	-100	-10	G
Hysteresis ($B_{OP} - B_{RP}$)	B_{HYS}	A3290	$T_A = 25^\circ\text{C}$ and $T_{A(max)}$	10	100	G
			$T_A = -40^\circ\text{C}$	–	100	G
		A3291	$T_A = 25^\circ\text{C}$ and $T_{A(max)}$	20	200	G
			$T_A = -40^\circ\text{C}$	–	200	G

¹The positive polarity symbol (+) indicates south magnetic field, and the negative polarity symbol (-) indicates north magnetic field.

²Required polarity observed and transition of magnetic gradient through B_{OP} . See functional description.

³Required polarity observed and transition of magnetic gradient through B_{RP} after B_{OP} . See functional description.

THERMAL CHARACTERISTICS may require derating at maximum conditions, see application information

Characteristic	Symbol	Test Conditions*	Value	Units
Package Thermal Resistance	$R_{\theta JA}$	Package LH, 1-layer PCB with copper limited to solder pads	228	$^{\circ}\text{C}/\text{W}$
		Package LH, 2-layer PCB with 0.463 in. ² of copper area each side connected by thermal vias	110	$^{\circ}\text{C}/\text{W}$
		Package UA, 1-layer PCB with copper limited to solder pads	165	$^{\circ}\text{C}/\text{W}$

*Additional thermal information available on Allegro website.

Power Derating Curve

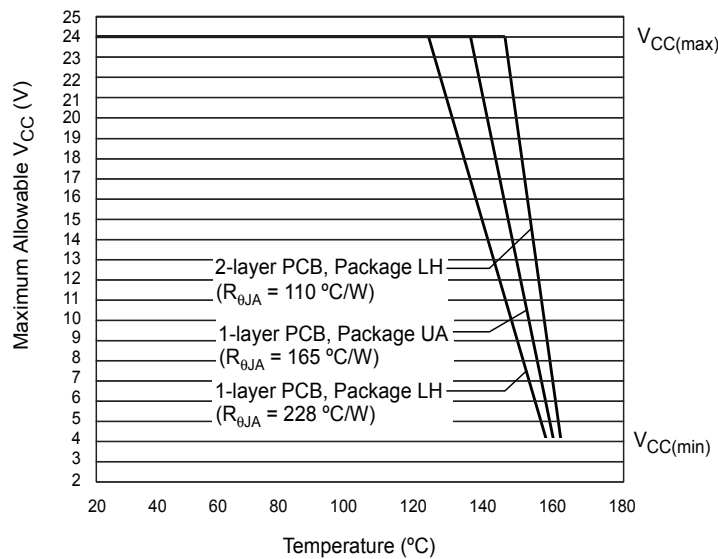

Power Dissipation versus Ambient Temperature

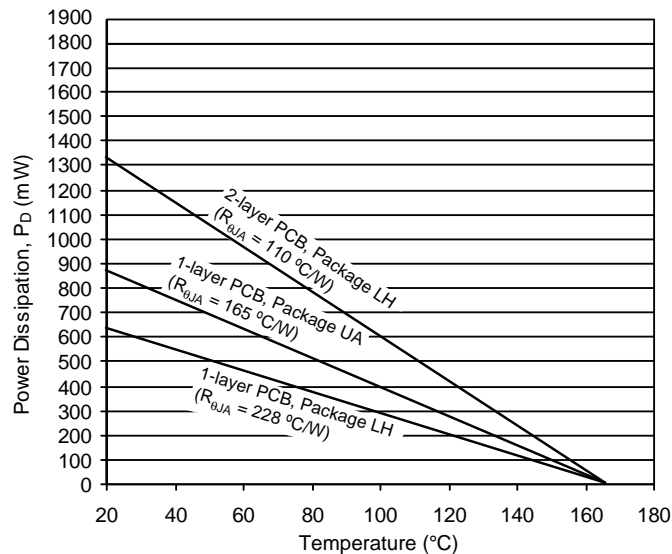

Functional Description

Chopper-Stabilized Technique

The Hall element can be considered as a resistor array similar to a Wheatstone bridge. A basic circuit is shown in figure 1, demonstrating the effect of the magnetic field flux density, B , impinging on the Hall element. When using Hall effect technology, a limiting factor for switchpoint accuracy is the small signal voltage, V_{HALL} , developed across the Hall element. This voltage is disproportionately small relative to the offset that can be produced at the output of the Hall device, caused by device overmolding, temperature dependencies, and thermal stress.

A large portion of the offset is a result of the mismatching of these resistors. The A3290 and A3291 use a proprietary dynamic offset cancellation technique, with an internal high-frequency clock, to reduce the residual offset. The chopper-stabilizing

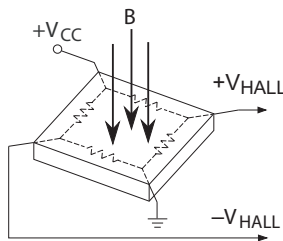

Figure 1. Hall element, basic circuit operation

technique cancels the mismatching of the resistor circuit by changing the direction of the current flowing through the Hall element. To do so, CMOS switches and Hall voltage measurement taps are used, while maintaining V_{HALL} signal that is induced by the external magnetic flux.

The signal is then captured by a sample-and-hold circuit and further processed using low-offset bipolar circuitry. This technique produces devices that have an extremely stable quiescent Hall output voltage, are immune to thermal stress, and have precise recoverability after temperature cycling. This technique will also slightly degrade the device output repeatability. A relatively high sampling frequency is used in order to process faster signals.

More detailed descriptions of the circuit operation can be found on the Allegro Web site, including: Technical Paper STP 97-10, *Monolithic Magnetic Hall Sensing Using Dynamic Quadrature Offset Cancellation*, and Technical Paper STP 99-1, *Chopper-Stabilized Amplifiers with a Track-and-Hold Signal Demodulator*.

Operation

The outputs of the A3290 and A3291 switch low (turn on) when a magnetic field perpendicular to the Hall element transitions through and exceeds the Operate Point threshold, B_{OP} . This is illustrated in figure 3. After turn-on, the output is capable of sinking 25 mA, and the output voltage reaches $V_{OUT(SAT)}$.

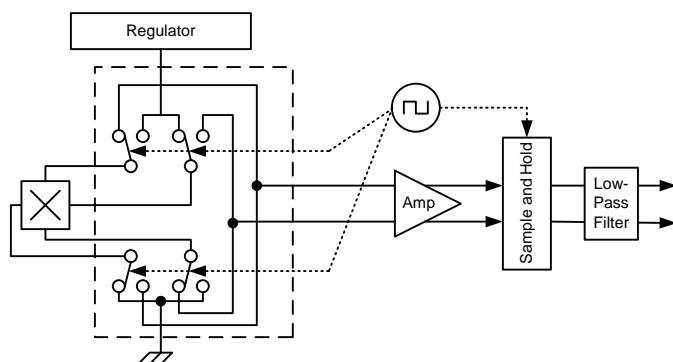

Figure 2. Chopper stabilization circuit (dynamic quadrature offset cancellation)

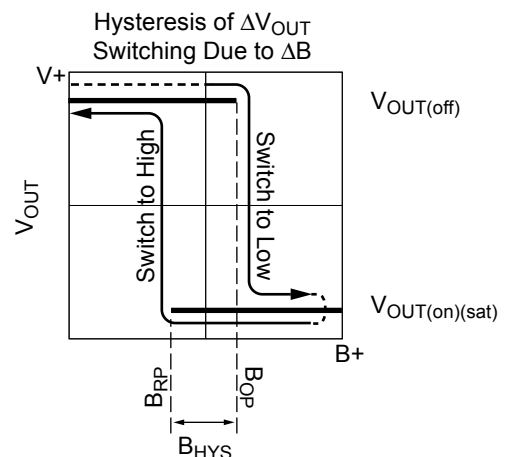

Figure 3. Output voltage responds to sensed magnetic flux density.

Note that these devices latch; that is, after a south (+) polarity magnetic field of sufficient strength impinging on the branded face of the device turns on the device, the device remains on until the magnetic field is reduced below the Release Point threshold, B_{RP} . At that transition, the device output goes high (turns off). The difference in the magnetic operate and release points is the hysteresis, B_{HYS} , of the device. This built-in hysteresis allows

clean switching of the output, even in the presence of external mechanical vibration and electrical noise.

When the devices are powered on, if the ambient magnetic field has an intensity that is between B_{OP} and B_{RP} , the initial output state is indeterminate. The first time that the level of B either rises through B_{OP} , or falls through B_{RP} , however, the correct output state is obtained.

Application Information

It is strongly recommended that an external bypass capacitor be connected (in close proximity to the Hall element) between the supply and ground of the device to reduce both external noise and noise generated by the chopper-stabilization technique. This configuration is shown in figure 4.

The simplest form of magnet that will operate these devices is a ring magnet. Other methods of operation, such as linear magnets, are possible.

The device must be operated below the maximum junction temperature of the device, $T_{J(max)}$. Under certain combinations of peak conditions, reliable operation may require derating supplied power or improving the heat dissipation properties of the application. The Package Thermal Resistance, $R_{\theta JA}$, is a figure of merit summarizing the ability of the application and the device to dissipate

heat from the junction (die), through all paths to the ambient air. Its primary component is the Effective Thermal Conductivity, K , of the printed circuit board, including adjacent devices and traces. Radiation from the die through the device case, $R_{\theta JC}$, is relatively small component of $R_{\theta JA}$. Ambient air temperature, T_A , and air motion are significant external factors, damped by overmolding. Sample power dissipation results are given in the Thermal Characteristics section. Additional thermal data is also available on the Allegro website.

Extensive applications information for Hall-effect devices is available in: *Hall-Effect IC Applications Guide*, Application Note 27701 and *Guidelines for Designing Subassemblies Using Hall-Effect Devices*, Application Note 27703.1

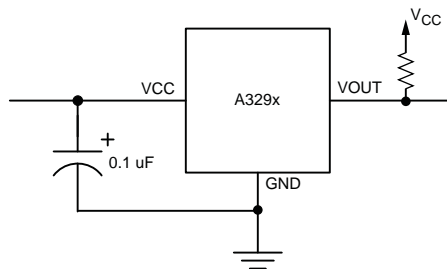
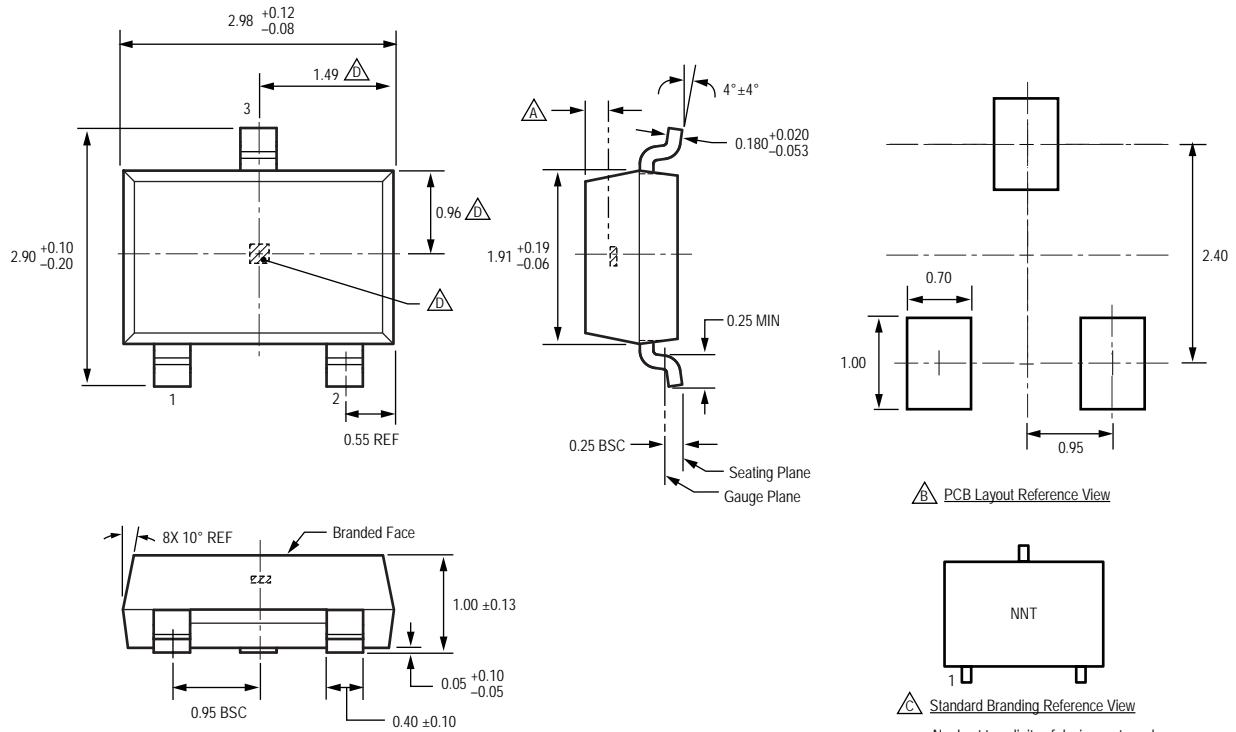

Figure 4. Typical basic application circuit. A bypass capacitor is highly recommended.

Package LH, 3-Pin SOT23W



For Reference Only; not for tooling use (reference dwg. 802840)
Dimensions in millimeters
Dimensions exclusive of mold flash, gate burrs, and dambar protrusions
Exact case and lead configuration at supplier discretion within limits shown

- $\triangle A$ Active Area Depth, 0.28 mm REF
- $\triangle B$ Reference land pattern layout
All pads a minimum of 0.20 mm from all adjacent pads; adjust as necessary to meet application process requirements and PCB layout tolerances
- $\triangle C$ Branding scale and appearance at supplier discretion
- $\triangle D$ Hall element, not to scale

$\triangle A$ PCB Layout Reference View

$\triangle C$ Standard Branding Reference View

N = Last two digits of device part number
T = Temperature code

**Package UA, 3-Pin SIP
Matrix Leadframe**

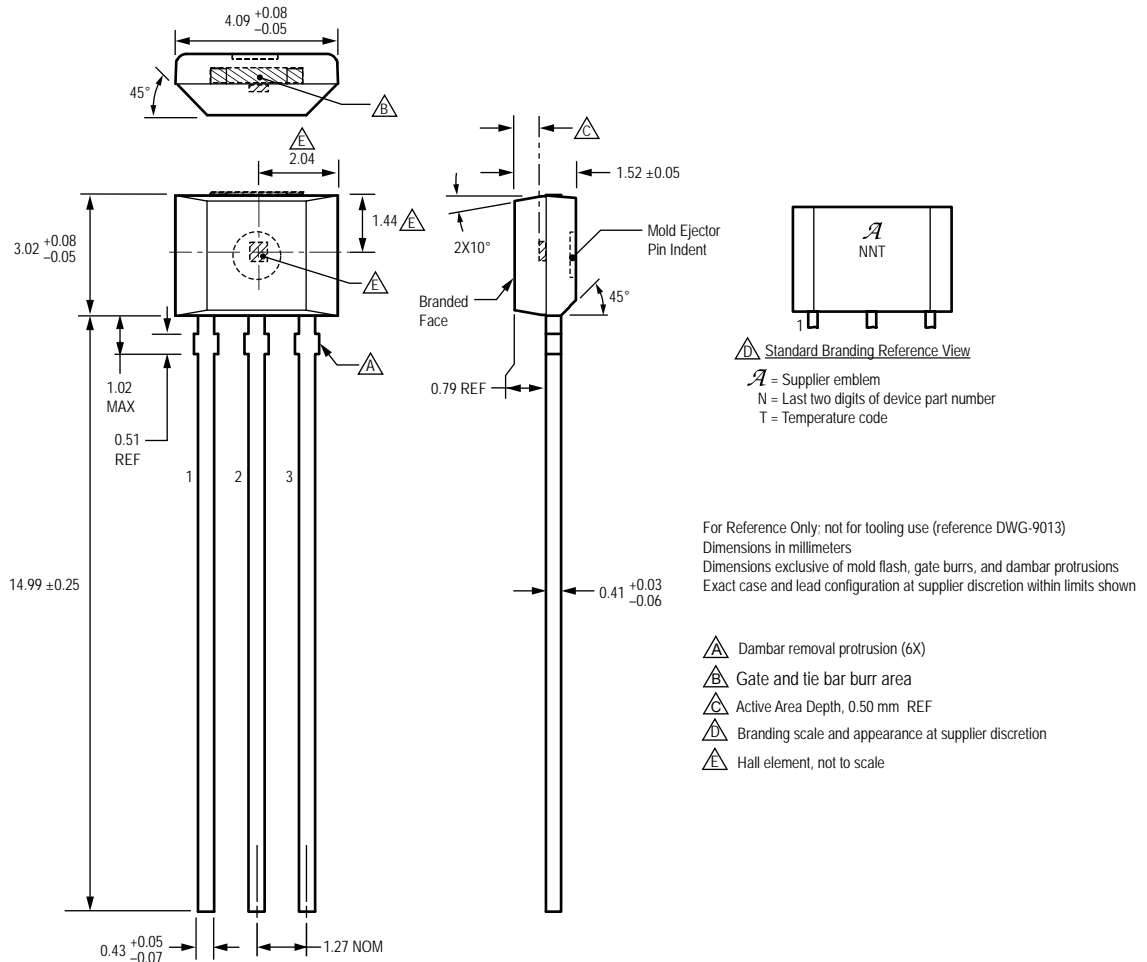

Please note that there are changes to the existing UA package drawing pending.
Please contact the Allegro Marketing department for additional information.

