

## DC-to-DC Step-Down Converter

### Features and Benefits

- 3.5 A output current supplied in a small, surface mount power package
- High efficiency: 83% at  $V_{IN}=15\text{ V}$ ,  $I_O=2.0\text{ A}$ ,  $V_O=5\text{ V}$
- Requires only six external components (optional soft start requires an additional capacitor)
- Oscillation circuit built-in (frequency 300 kHz typical)
- Constant-current mode overcurrent protection circuit and overtemperature protection circuit built-in
- Soft start function built-in (can be implemented as an on/off function; output-off state at low level)
- Low current consumption during output-off state

### Package: TO263-5

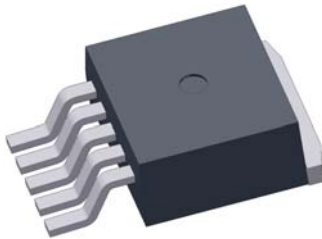

Not to scale

### Description

The SI-8001FDE DC voltage regulator is a DC-to-DC buck convertor that attains an oscillation frequency of 300 kHz, and has an integrated miniaturized choke coil, allowing it to serve as a small, high efficiency power supply in a compact TO263 package.

The internal switching regulator function provides high efficiency switching regulation without any need for adjustment. The device requires only six external support components. The optional soft start function requires an additional capacitor. Optional on/off control can be performed using a transistor. The SI-8001FDE includes overcurrent and overtemperature protection circuits.

Applications include:

- DVD recorder
- FPD TV
- Telecommunications equipment
- Office automation equipment, such as printers
- On-board local power supply
- Output voltage regulator for second stage of SMPS (switched mode power supply)

### Functional Block Diagram

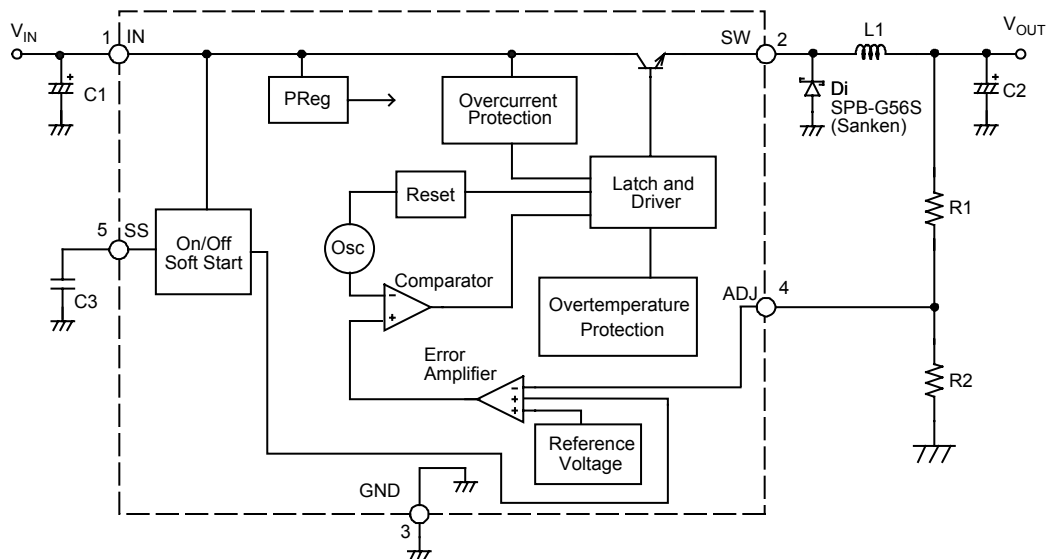

## Selection Guide

Part Number	Output Voltage Adjustable Range (V)	Efficiency, Typ. (%)	Input Voltage, Max. (V)	Output Current, Max. (A)	Packing
SI-8001FDE-TL	0.8 to 24	83	40	3.5	800 pieces per reel

## Absolute Maximum Ratings

Characteristic	Symbol	Remarks	Rating	Units
DC Input Voltage	$V_{IN}$		43	V
Power Dissipation	$P_D$	Mounted on 40 mm × 40 mm exposed copper area on 40 mm × 40 mm glass-epoxy PCB; limited by internal overtemperature protection.	3	W
Junction Temperature	$T_J$	Internal overtemperature protection circuit may enable when $T_J \geq 130^\circ\text{C}$ . During product operation, recommended $T_J \leq 125^\circ\text{C}$ .	-40 to 150	$^\circ\text{C}$
Storage Temperature	$T_{stg}$		-40 to 150	$^\circ\text{C}$
Thermal Resistance (junction-to-case)	$R_{\theta JC}$	Mounted on 40 mm × 40 mm exposed copper area on 40 mm × 40 mm glass-epoxy PCB.	3	$^\circ\text{C/W}$
Thermal Resistance (junction-to-ambient air)	$R_{\theta JA}$	Mounted on 40 mm × 40 mm exposed copper area on 40 mm × 40 mm glass-epoxy PCB.	33.3	$^\circ\text{C/W}$

## Recommended Operating Conditions\*

Characteristic	Symbol	Remarks	Min.	Max.	Units
DC Input Voltage Range	$V_{IN}$	$V_{IN}(\text{min})$ is the greater of 4.5 V or $V_O + 3$ V.	See remarks	40	V
DC Output Voltage Range	$V_O$		0.8	24	V
DC Output Current Range	$I_O$	$V_{IN} \geq V_O + 3$ V; to be used within the allowable package power dissipation characteristics (refer to Power Dissipation chart).	0	3.5	A
Operating Junction Temperature Range	$T_{JOP}$		-30	100	$^\circ\text{C}$
Operating Temperature Range	$T_{OP}$	To be used within the allowable package power dissipation characteristics (refer to Power Dissipation chart).	-30	85	$^\circ\text{C}$

\*Required for normal device functioning according to Electrical Characteristics table.

All performance characteristics given are typical values for circuit or system baseline design only and are at the nominal operating voltage and an ambient temperature,  $T_A$ , of  $25^\circ\text{C}$ , unless otherwise stated.

### ELECTRICAL CHARACTERISTICS<sup>1</sup>, valid at T<sub>A</sub> = 25°C, V<sub>O</sub> = 5 V (adjusted), R<sub>1</sub> = 4.2 kΩ, R<sub>1</sub> = 0.8 kΩ

Characteristic	Symbol	Test Conditions <sup>1</sup>	Min.	Typ.	Max.	Units
Reference Voltage	V <sub>ADJ</sub>	V <sub>IN</sub> = 15 V, I <sub>O</sub> = 0.2 A	0.784	0.800	0.816	V
Reference Voltage Temperature Coefficient	ΔV <sub>ADJ</sub> /ΔT	V <sub>IN</sub> = 15 V, I <sub>O</sub> = 0.2 A, T <sub>C</sub> = 0 to 100 °C	–	±0.1	–	mV/°C
Efficiency <sup>2</sup>	η	V <sub>IN</sub> = 15 V, I <sub>O</sub> = 2 A	–	83	–	%
Operating Frequency	f <sub>O</sub>	V <sub>IN</sub> = 15 V, I <sub>O</sub> = 2 A	270	300	330	kHz
Line Regulation	V <sub>Line</sub>	V <sub>IN</sub> = 10 to 30 V, I <sub>O</sub> = 2 A	–	–	80	mV
Load Regulation	V <sub>Load</sub>	V <sub>IN</sub> = 15 V, I <sub>O</sub> = 0.2 to 3.5 A	–	–	50	mV
Overcurrent Protection Threshold Current	I <sub>S</sub>	V <sub>IN</sub> = 15 V	3.6	–	–	A
SS Terminal On/Off Operation Threshold Voltage	V <sub>SSL</sub>		–	–	0.5	V
SS Terminal On/Off Operation Outflow Current	I <sub>SSL</sub>	V <sub>SSL</sub> = 0 V	–	6	30	μA
Quiescent Current 1	I <sub>q</sub>	V <sub>IN</sub> = 15 V, I <sub>O</sub> = 0 A	–	6	–	mA
Quiescent Current 2	I <sub>q(off)</sub>	V <sub>IN</sub> = 15 V, V <sub>SS</sub> = 0 V	–	200	600	μA

<sup>1</sup>Using circuit shown in Typical Application Circuit diagram.

<sup>2</sup>Efficiency is calculated as:  $\eta(\%) = ([V_O \times I_O] \times [V_{IN} \times I_{IN}]) \times 100$ .

### Pin-out Diagram

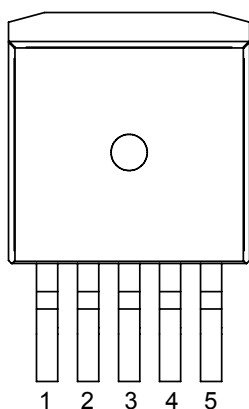

### Terminal List Table

Name	Number	Function
IN	1	Supply voltage
SW	2	Regulated supply output
GND	3	Ground terminal
ADJ	4	Terminal for resistor bridge feedback
SS	5	<p>The SS terminal is used to enable soft start and to control on/off operation of the IC output, V<sub>O</sub> (see figure 2). If neither soft start nor on/off control is used, leave pin open.</p> <p>To enable soft start, connect a capacitor between SS and ground. To control on/off operation, connect an NPN bipolar transistor, in a TTL open collector output configuration, between the SS terminal and GND. Turn off is done by decreasing V<sub>SSL</sub> below its rated level.</p> <p>When both soft start and V<sub>O</sub> on/off are used, a protection measure such as current limiting is required because, if the capacitance of C3 large, the discharge current of C3 flows across the transistor for on/off operation. Because a pull-up type resistor is provided inside the IC, no external voltage can be applied.</p>

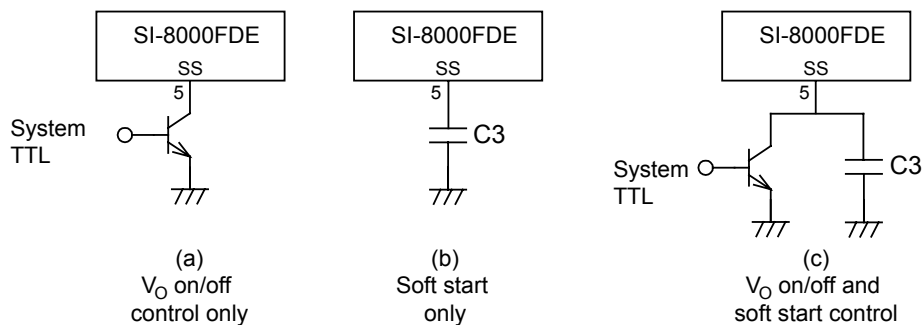
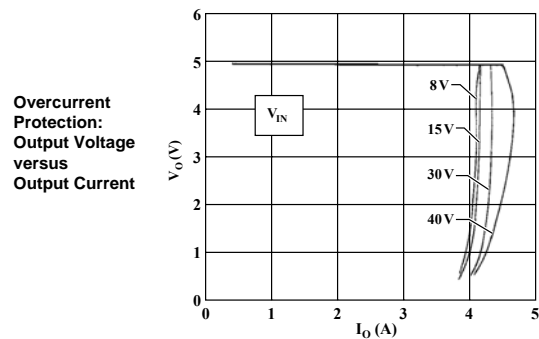
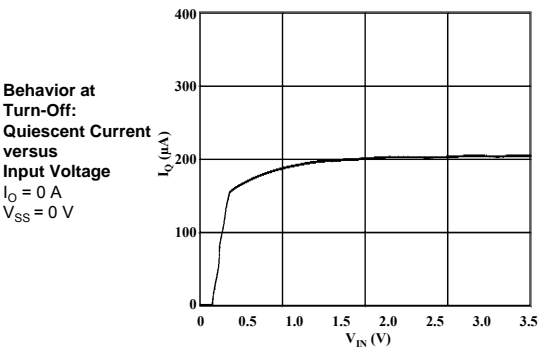
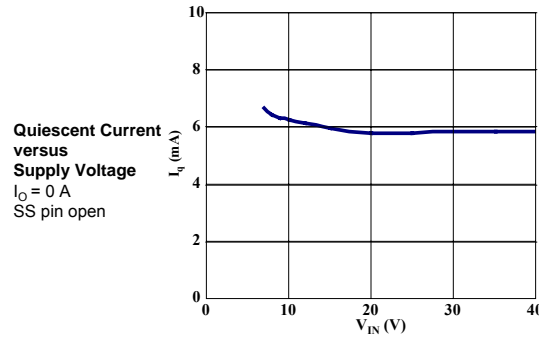
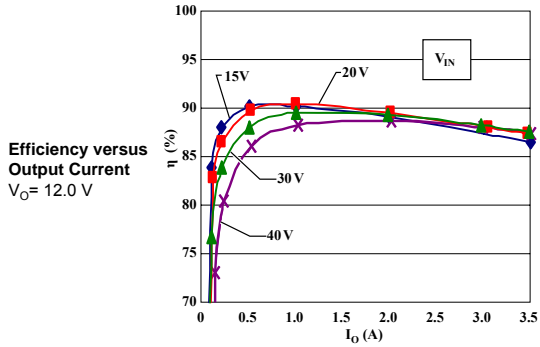
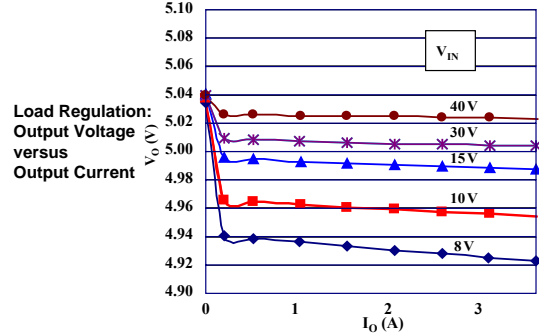
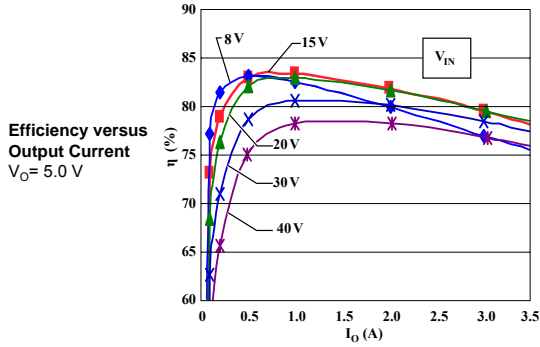
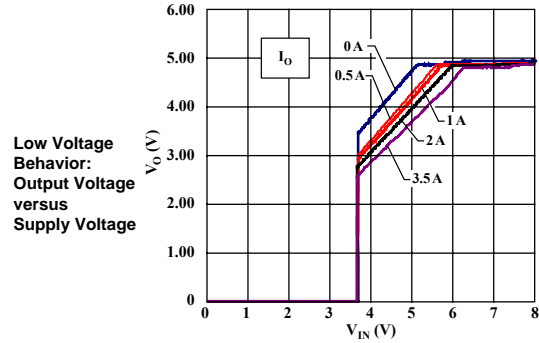
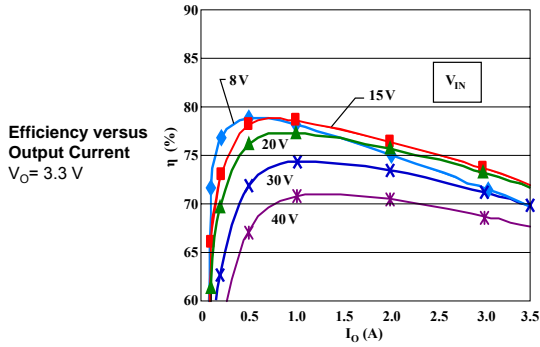

Figure 2. Alternative configurations for SS pin. If neither soft start nor V<sub>O</sub> on/off is required, the SS pin is left open.

Performance Characteristics

At  $T_A = 25^\circ\text{C}$ ,  $V_O = 5\text{ V}$  Adjusted,  $R_1 = 4.2\text{ k}\Omega$ ,  $R_2 = 0.8\text{ k}\Omega$



## Thermal Performance Characteristics

The application must be designed to ensure that the  $T_J(\text{max})$  of the device is not exceeded during operation. To do so, it is necessary to determine values for maximum power dissipation,  $P_D(\text{max})$ , and ambient temperature,  $T_A(\text{max})$ .

The relationships of  $T_J$ ,  $P_D$ ,  $T_A$ , and case temperature,  $T_C$ , are as shown in the following formulas:

$$P_D = \frac{T_J - T_C}{R_{\theta JC}} \quad \text{and} \quad P_D = \frac{T_J - T_A}{R_{\theta JA}}$$

$P_D$  can be calculated from input values:

$$P_D = V_O \cdot I_O \left( \frac{100}{\eta_x} - 1 \right) - V_F \cdot I_O \left( 1 - \frac{V_O}{V_{IN}} \right)$$

where:

$V_O$  is output voltage in V,

$V_{IN}$  is input supply voltage in V,

$I_O$  is output current in A,

$\eta_x$  is IC efficiency in percent (varies with  $V_{IN}$  and  $I_O$ ; refer to efficiency performance curves for value), and

$V_F$  is forward voltage for the input diode, Di. In these tests, the Sanken SPB-G56S was used, at 0.4 V. For application design, obtain thermal data from the datasheet for the diode.

$P_D$  is substantially affected by the heat conductance properties of the application, in particular any exposed copper area on the PCB where the device is mounted. The relationships of  $P_D$ ,  $T_A$ , and copper area is represented in the Power Dissipation chart.

$R_{\theta JA}$  for a given copper area can be determined from the Device Thermal Resistance chart. This can be substituted into the formula above to determine the  $T_J(\text{max})$  allowable in the application. Generally, more than 10% to 20% derating is required.

Because the heat dissipation capacity of the copper area depends substantially on how it is used in the actual application, thermal characteristics of the application must be confirmed by testing.  $T_C$  is determined by connecting a thermocouple to the device as shown here:

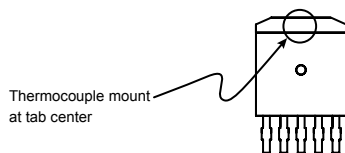

And analyzing the results using the following formula:

$$T_J = P_D \times R_{\theta JC} + T_C$$

for this device,  $R_{\theta JC}$  is 3 °C/W.

### Power Dissipation versus Ambient Temperature

$T_J(\text{max}) = 125^\circ\text{C}$ ; Mounted on glass-epoxy PCB (40 mm × 40 mm), with varying exposed copper areas

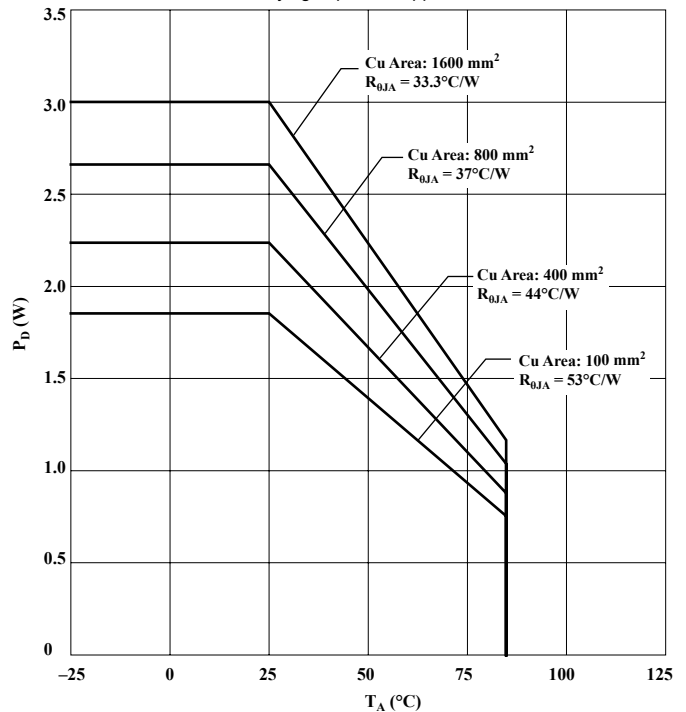

### Device Thermal Resistance versus Exposed Copper Area on PCB

Glass-epoxy PCB, 40 mm × 40 mm

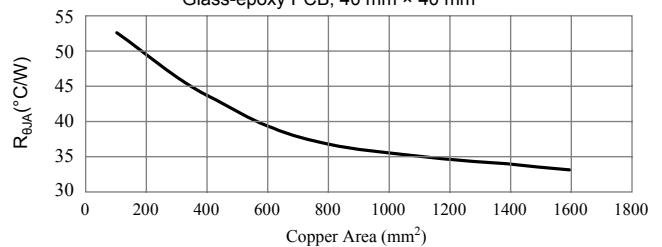

**Overtemperature Protection: Output Voltage versus Junction Temperature**  
 $V_{IN} = 15 \text{ V}$ ,  $I_O = 10 \text{ mA}$

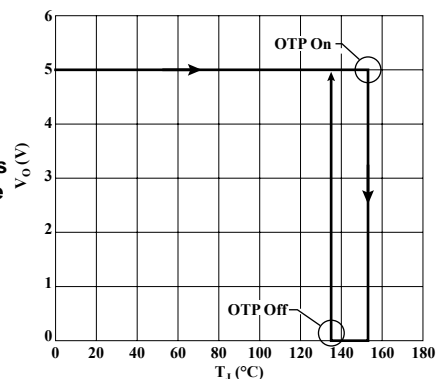

## Component Selection

**Diode Di** A Schottky-barrier diode must be used for Di. If other diode types are used, such as fast recovery diodes, the IC may be destroyed because of the reverse voltage applied by the recovery voltage or ON voltage.

**Choke Coil L1** If the winding resistance of the choke coil is too high, the efficiency may be reduced below rating. Because the overcurrent protection start current is approximately 4.2 A, attention must be paid to the heating of the choke coil by magnetic saturation due to overload or short-circuited load.

**Capacitors C1, C2, and C3** Because for SMPS, large ripple currents flow across C1 and C2, capacitors with high frequency and low impedance must be used. If the impedance of C2 is too high, the switching waveform may not be normal at low temperatures. Do not use either OS or tantalum types of capacitors for

C2 or C3, because the extremely low ESR causes an abnormal oscillation.

The device is stabilized, and for proper operation, C1 must be located close to the device (see layout diagram, below). C3 is required only if the soft start function is used. If not using soft-start, leave the SS terminal open. A pull-up resistor is provided inside the IC.

**Resistor Bridge R1 and R2** R1 and R2 comprise the resistor bridge for the output voltage,  $V_O$ , and are calculated as follows:

$$R1 = \frac{(V_O - V_{ADJ})}{I_{ADJ}} = \frac{(V_O - 0.8)}{1 \times 10^{-3}} (\Omega), \text{ and } R2 = \frac{V_{ADJ}}{I_{ADJ}} = \frac{0.8}{1 \times 10^{-3}} = 0.8 (\text{k}\Omega)$$

$I_{ADJ}$  should always be set to 1 mA. Note that R2 should always be present to ensure stable operation, even if  $V_O$  is set to 0.8 V (that is, even if there is no R1).  $V_O$  should be at least  $V_{IN} + 8\%$ .

Typical Application Diagram

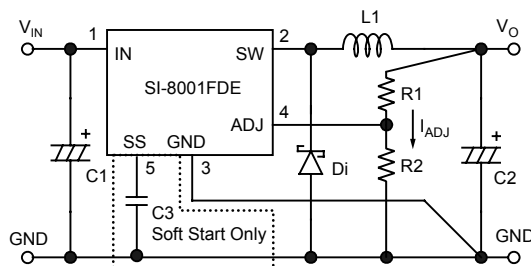

Recommended PCB Layout

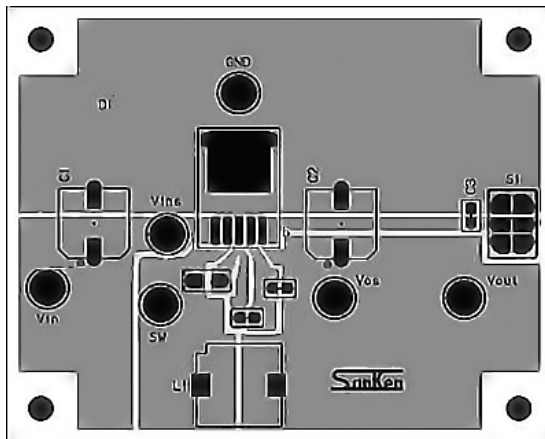

All external components should be mounted as close as possible to the SI-8001FDE. The ground of all components should be connected at one point near GND pin (pin 3).

Component	Rating
C1	470 $\mu$ F
C2	680 $\mu$ F
C3	0.1 $\mu$ F (For soft start function)
Di	SPB-G56S (Sanken)
L1	47 $\mu$ H

Recommended Solder Pad Layout

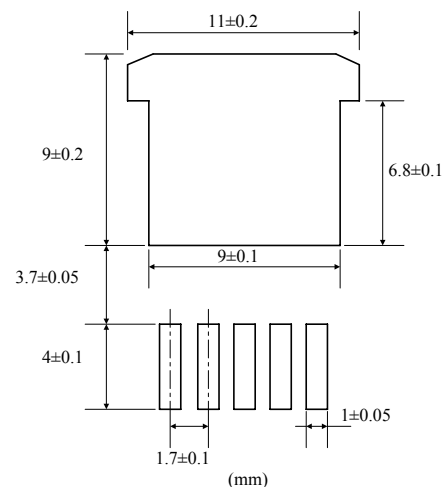



TAPE AND REEL SPECIFICATION

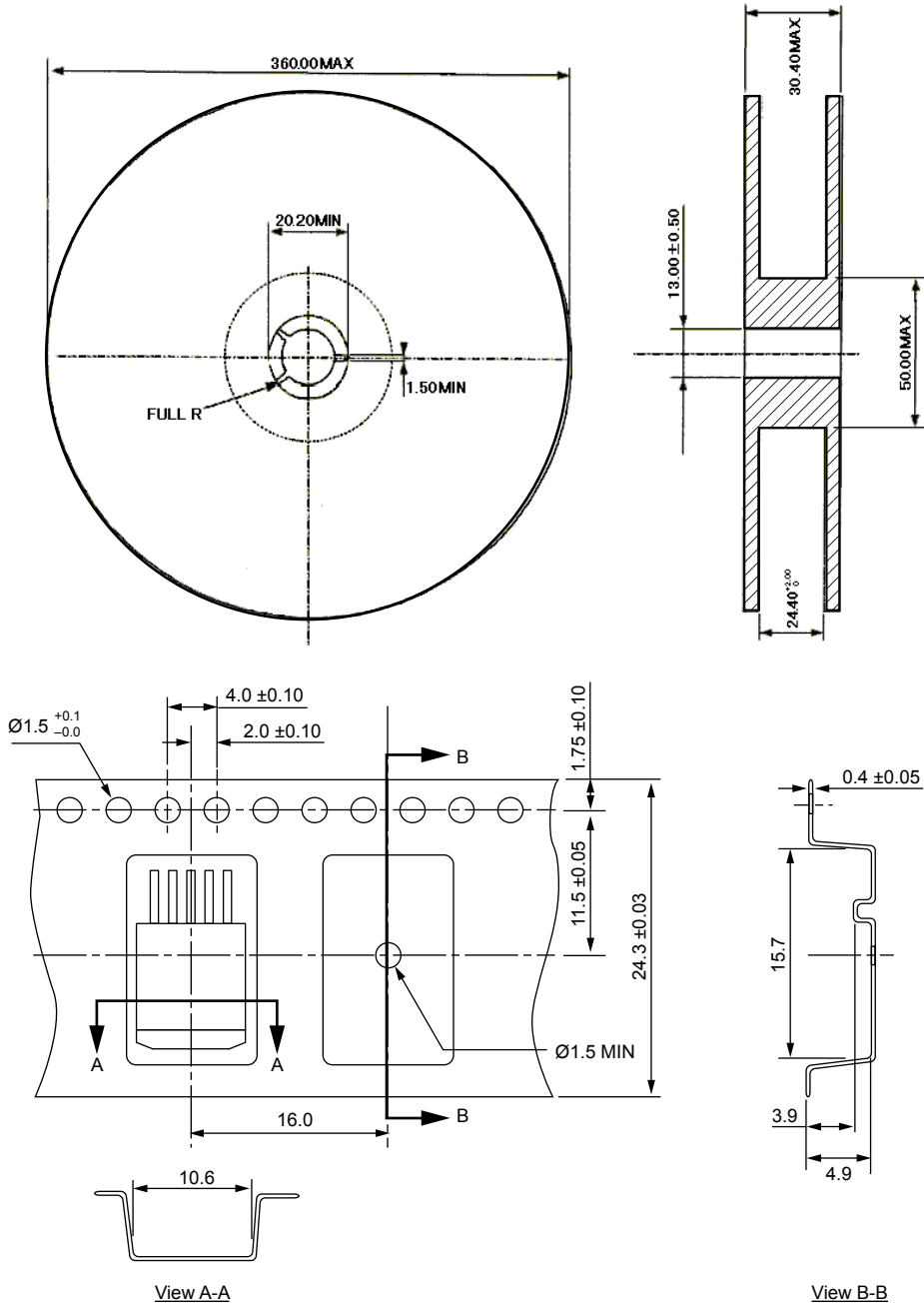

Material: conductive polystyrene  
 Camber < 1 mm over 100 length of tape  
 Pocket inner widths measured 0.3 mm above floor of pocket  
 Pocket position relative to sprocket hole measured to true position of pocket  
 10 sprocket hole pitch cumulative  $\pm 0.2$  mm  
 Pocket center and pocket hole center  $\pm 0.3$  mm  
 Surface resistivity <  $10^7 \Omega / \text{cm}^2$

PACKING SPECIFICATION

Inner Carton  
800 pieces per reel  
2 reels per carton

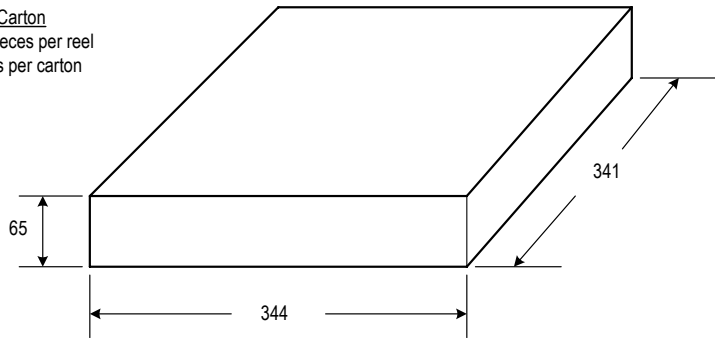

Outer Carton  
3 inner cartons per outer carton

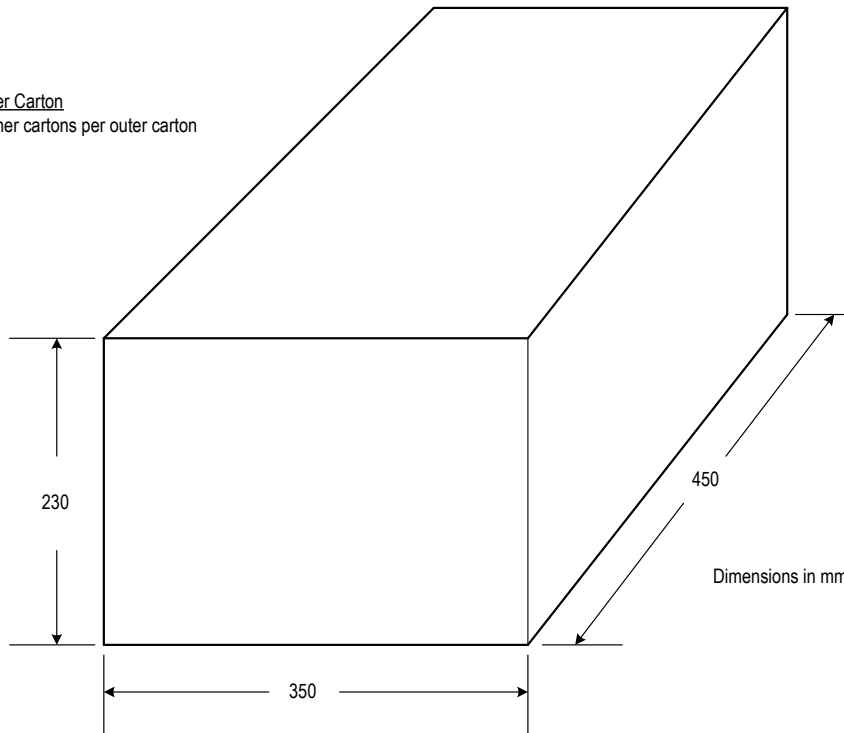

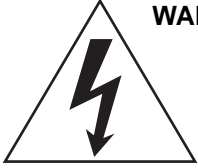

**WARNING** — These devices are designed to be operated at lethal voltages and energy levels. Circuit designs that embody these components must conform with applicable safety requirements. Precautions must be taken to prevent accidental contact with power-line potentials. Do not connect grounded test equipment.

The use of an isolation transformer is recommended during circuit development and breadboarding.

### Cautions for Use

- Operation of the product in parallel to increase current is not permitted.
- Although the product has an internal overtemperature protection circuit, that is intended only to protect the product from temporary excess heating due to overloads. Long-term reliability cannot be guaranteed when the product is operated under continuous overload conditions.

Because reliability can be affected adversely by improper storage environments and handling methods, please observe the following cautions.

### Cautions for Storage

- Ensure that storage conditions comply with the standard temperature (5°C to 35°C) and the standard relative humidity (around 40 to 75%); avoid storage locations that experience extreme changes in temperature or humidity.
- Avoid locations where dust or harmful gases are present and avoid direct sunlight.
- Reinspect for rust on leads and solderability of products that have been stored for a long time.

### Cautions for Testing and Handling

When tests are carried out during inspection testing and other standard test periods, protect the products from power surges from the testing device, shorts between adjacent products, and shorts to the heatsink.

### Electrostatic Discharge

- When handling the products, operator must be grounded. Grounded wrist straps worn should have at least 1 MΩ of resistance to ground to prevent shock hazard.
- Workbenches where the products are handled should be grounded and be provided with conductive table and floor mats.
- When using measuring equipment such as a curve tracer, the equipment should be grounded.
- When soldering the products, the head of soldering irons or the

solder bath must be grounded in order to prevent leak voltages generated by them from being applied to the products.

- The products should always be stored and transported in our shipping containers or conductive containers, or be wrapped in aluminum foil.

### Soldering

- When manually soldering the products, please be sure to minimize the working time, within the following limits:

Soldering Iron Temperature (°C)	Time (s)
380±10	3 (once only)

- Reflow soldering can be performed a maximum of twice, using the following recommended profile:

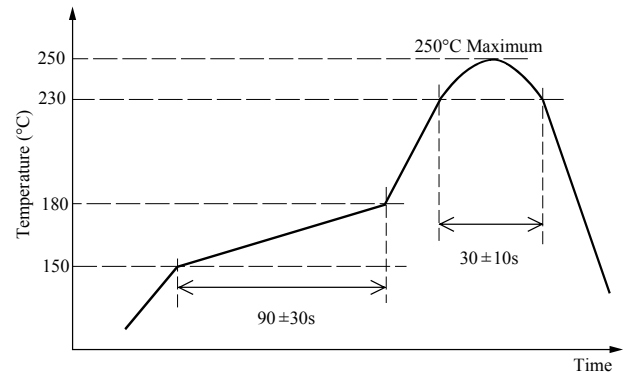

---

*The products described herein are manufactured in Japan by Sanken Electric Co., Ltd. for sale by Allegro MicroSystems, Inc.*

*Sanken and Allegro reserve the right to make, from time to time, such departures from the detail specifications as may be required to permit improvements in the performance, reliability, or manufacturability of its products. Therefore, the user is cautioned to verify that the information in this publication is current before placing any order.*

*The information included herein is believed to be accurate and reliable. Application and operation examples described in this document are given for reference only and Sanken assumes no responsibility for any infringement of industrial property right, intellectual property rights or any other rights of Sanken or any third party which may result from its use.*

*When using the products herein, the applicability and suitability of such products for the intended purpose shall be the users responsibility to determine.*

*Although Sanken undertakes to enhance the quality and reliability of its products, the occurrence of failure and defect of semiconductor products at a certain rate is inevitable.*

*Users of Sanken products are requested to take, at their own risk, preventative measures including safety design of the equipment or systems against any possible injury, death, fires or damages to society due to device failure or malfunction.*

*Sanken products listed in this document are designed and intended for the use as components in general purpose electronic equipment or apparatus (home appliances, office equipment, telecommunication equipment, measuring equipment, etc.). When considering the use of Sanken products in the applications where higher reliability is required (transportation equipment and its control systems, traffic signal control systems or equipment, fire/crime alarm systems, various safety devices, etc.), please contact your nearest Sanken sales representative to discuss and obtain written confirmation of your specifications.*

*The use of Sanken products without the written consent of Sanken in the applications where extremely high reliability is required (aerospace equipment, nuclear power control systems, life support systems, etc.) is strictly prohibited. Anti-radioactive ray design is not considered for the products listed herein.*

Copyright © 2007 Allegro MicroSystems, Inc.  
This datasheet is based on Sanken datasheet SSJ-03222

For the latest version of this document, visit our website:  
[www.allegromicro.com](http://www.allegromicro.com)



Allegro MicroSystems, Inc.  
115 Northeast Cutoff, Box 15036  
Worcester, Massachusetts 01615-0036 (508) 853-5000  
[www.allegromicro.com](http://www.allegromicro.com)

