



HIGH-EFFICIENCY EZ PACKAGE WITH ULTRALOW POWER DISSIPATION IN A COMPACT 16 MM² FOOTPRINT

Current Sensors System Engineering
Allegro MicroSystems

INTRODUCTION

As the world continues to electrify, *efficiency* is the key to success—efficiency as in low power dissipation that allows converting every milliwatt of power into useful work, but also efficiency in the sense of building compact and cost-competitive electrical systems in a short design cycle.

The Allegro ACS37220 in the new EZ package is the most efficient integrated current sensing solution for up to a ± 200 A range for low-voltage electrical systems.

HIGH CURRENTS IN A SMALL FOOTPRINT

The EZ package is a 4 mm \times 4 mm custom quad-flat no-lead (QFN) package for integrated-conductor current sensors. It is an automotive Grade 0 package capable of operating between -40°C and $+150^{\circ}\text{C}$. The package has two pins for the input and output of the measured current and five additional signal pins. The primary current path is galvanically isolated from the five signal pins with a 100 V_{RMS} functional isolation. In the ACS37220, the current through the package is sensed using differential Hall plates and is reported as an analog signal at the VOUT pin. Despite its compact size, the EZ package has been designed to measure PCB currents of up to 200 A.

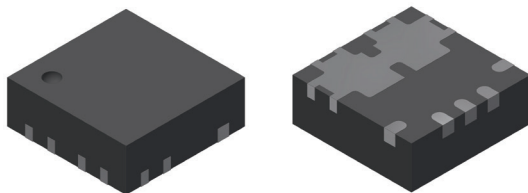

Figure 1: The Allegro EZ integrated current sensor package—A compact 4 mm \times 4 mm QFN package with two pins for the measured current and five additional signal pins.

EXTREME EFFICIENCY

Handling up to 200 A in a 4 mm \times 4 mm footprint requires extreme efficiency for the primary current, and the EZ package delivers exactly that with an impressive 0.1 m Ω internal conductor resistance. As a result, in most applications, the resistance of the ACS37220 is comparable to that of the adjacent PCB traces and does not drive up the power dissipation of the system. Large input and output pads for the primary current, at the bottom of the EZ package, ensure excellent thermal contact with the PCB, thereby increasing thermal dissipation from the sensor. In addition to the improved energy efficiency, the ultralow primary resistance also ensures that the ACS37220 does not drive up the overall thermal management requirements of the system.

On the Allegro evaluation board ACSEVB-EZ7, with six layers of 2 oz. copper, the sensor can continuously measure more than 140 A at room temperature, without any forced cooling (Figure 2).

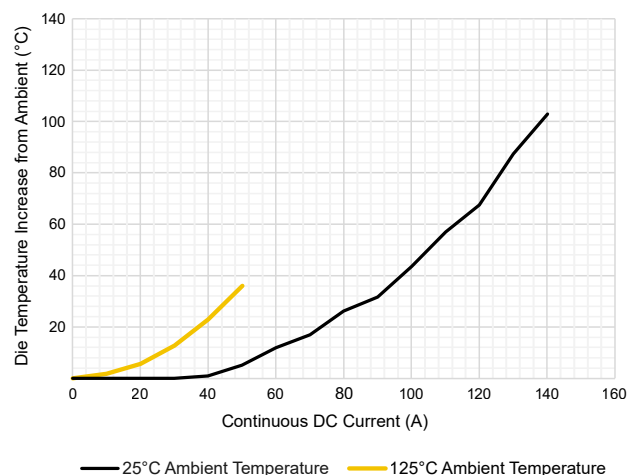

Figure 2: Temperature increase of ACS37220 in EZ package versus applied continuous DC current at two ambient temperatures, $T_A = 25^{\circ}\text{C}$ and $T_A = 125^{\circ}\text{C}$, as measured on the Allegro evaluation board ACSEVB-EZ7.

ADVANCED FUNCTIONALITY

As with any integrated-conductor current sensor by Allegro, the ACS37220 is a system IC that is a complete and easy-to-use sensing solution. All parts are factory-calibrated to achieve high accuracy and feature built-in signal conditioning, including temperature and stress compensation. Additionally, the ACS37220 offers an overcurrent alarm signal, at the separate FAULT pin, that activates low when the measured current exceeds an adjustable threshold. This signal can be used, for example, to enhance safety by rapidly switching off sections of the electrical system. The overcurrent threshold is user-adjustable, at the VOC pin, by a simple resistor to ground (Figure 3). All of this makes the ACS37220 in the EZ package easy to integrate, with only a minimal number of additional passive components.

CONCLUSION

When it comes to sensing high PCB currents in low-voltage applications and the emphasis is on design efficiency, the ACS37220 in the EZ package redefines the industry benchmarks. With its extreme overall efficiency and rich functionality, the EZ package is truly the easy choice.

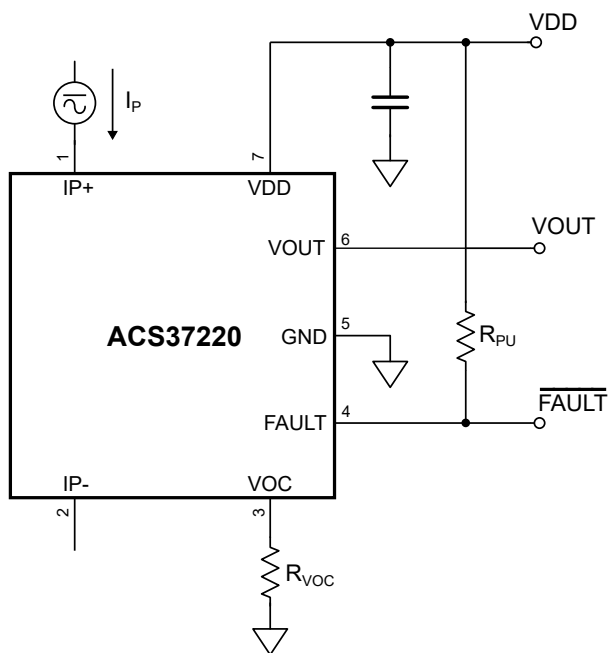

Figure 3: Typical application circuit of the ACS37220. In addition to the output signal at VOUT, the FAULT pin activates low when the measured current exceeds a user-adjustable threshold. The threshold level is set via the value of the R_{VOC} resistor.

Revision History

Number	Date	Description
-	July 9, 2024	Initial release

Copyright 2024, Allegro MicroSystems.

The information contained in this document does not constitute any representation, warranty, assurance, guaranty, or inducement by Allegro to the customer with respect to the subject matter of this document. The information being provided does not guarantee that a process based on this information will be reliable, or that Allegro has explored all of the possible failure modes. It is the customer's responsibility to do sufficient qualification testing of the final product to insure that it is reliable and meets all design requirements.

Copies of this document are considered uncontrolled documents.