

# POWERING THE PEDAL REVOLUTION

## Driving Efficiency and Natural Control in Next-Gen e-Bicycles

The e-bicycle market is diversifying rapidly, evolving from simple city commuters to high-performance electric mountain bikes (e-MTBs) capable of conquering steep, technical terrain. Whether navigating crowded city streets or rugged off-road trails, modern riders demand a seamless extension of their own power. This requires sophisticated drive systems that deliver high torque for climbing and acceleration without sacrificing the natural "cycling feel," all while maximizing battery range to keep the adventure going longer.

Designers face the challenge of integrating complex motor control and sensing into tight spaces like frame tubes without overheating. Success depends on maximizing battery efficiency for longer range and utilizing high-resolution torque sensing to ensure the electric assist feels smooth and instantaneous, rather than jerky. Components must also be rugged enough to withstand constant vibration, moisture, and road debris.

### What You Can Achieve with Allegro Solutions:

- **Extended Range:** High-efficiency gate drivers and ultra-low resistance current sensors reduce inverter power loss. This optimization extends riding range for long commutes or trail rides, maximizing every charge.
- **Natural Control:** Allegro's high-bandwidth sensors and driver ICs enable precise Field Oriented Control (FOC). This delivers immediate, jerk-free power that feels like a natural extension of the rider, ensuring traction on any terrain.
- **Rugged Safety:** Designed for automotive standards, our sensors offer unmatched immunity to vibration and debris. This ensures critical functions operate reliably in the harshest environments, from rain-soaked streets to muddy trails.



Riders are driving a rapid shift toward high-performance e-bikes both for their daily commute and weekend adventure.

Allegro empowers this evolution with compact, energy-efficient power and sensing solutions. Our technology ensures a smooth, natural ride while extending battery life for any bike path.

## Block Diagram

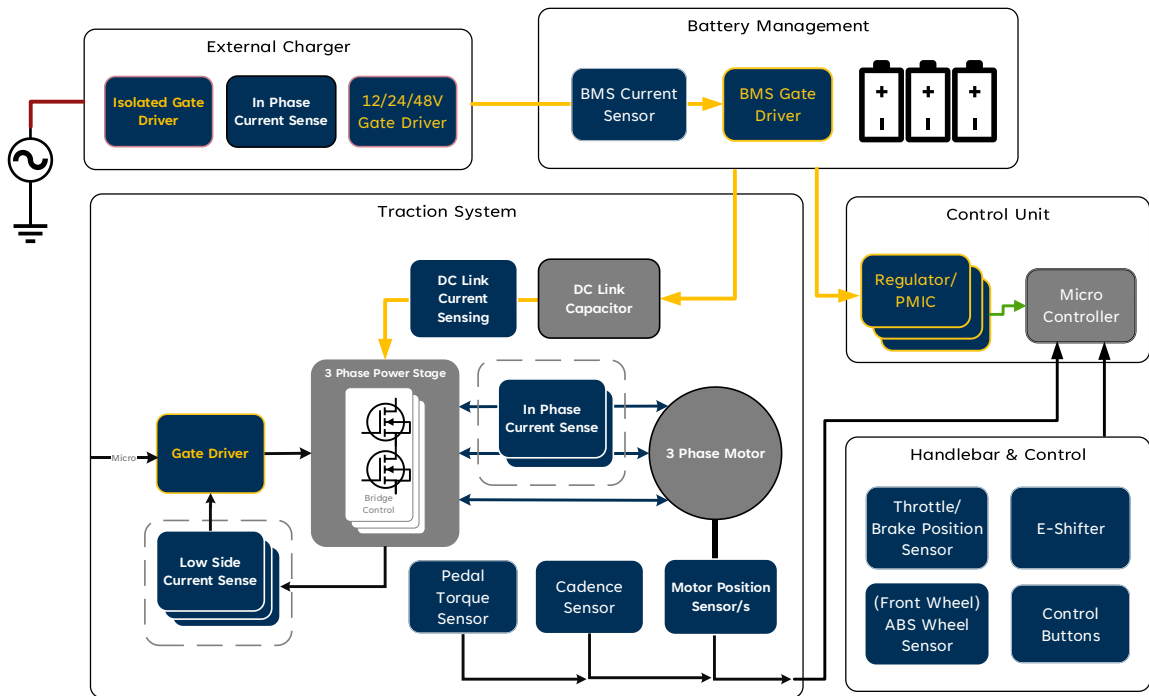

## Key Products and Solutions

Subsystem	Component	Allegro Parts	Key Differentiator
Traction System	Gate driver	A89211/2	Integrated MCU and gate driver for space efficiency
		AMT49100/1	ASIL-D compliant driver with integrated buck
	Current Sensor	ACS37220	Ultra-low resistance to extend battery range
	Position Sensing	A33020/2/3	Precise 360° sensing near high currents without shielding
		A17802/3	Vibration-proof inductive design ideal for bottom brackets
	Torque Sensor	A17810	Contactless, wear-free torque sensing
Cadance Sensor	A19580	Large air-gap tolerance simplifies ferrous gear sensing	
Battery System	Current Sensor	ACS37220	Unparalleled power density
	Gate driver	A89500	48V rate with low sleep current
Control Unit	Regulator/PMIC	A8586	Power your electronics directly from the main battery
Handlebar & Control	Throttle & Brake	A31315	3D sensing enables off-axis magnets
	Speed Sensor	A/TS19200	Compact, integrated package for precise speed
	E-Shifter Stepper	A5984	Silent stepper driving for premium electronic shifting
		A31316	PCB-less package for in tight spaces
	Control Buttons	APS11203	High-voltage operation eliminates 5V regulators



To learn more about the Allegro family of products and to explore available design resources, visit [allegromicro.com](http://allegromicro.com)