

ELECTRIFYING THE OPEN ROAD

Unleashing Performance and Reliability in Electric Motorcycles



Electric motorcycles are rapidly transitioning from niche novelties to high-performance machines that rival their internal combustion counterparts in speed and power. As the market moves toward higher voltages to achieve faster charging times and blistering acceleration, the underlying electronics must evolve to handle these extreme demands. The goal is to deliver an exhilarating riding experience that offers the silent, instant torque of electric propulsion without compromising the safety, range, or durability riders expect from a premium vehicle.

Developing these machines requires high-voltage systems capable of managing extreme heat and power density without bulky cooling. Engineers must ensure robust isolation to protect control circuits while delivering the instant throttle response riders crave. The system must also remain lightweight to maintain handling agility, necessitating highly integrated components that reduce board space and overall weight.

What You Can Achieve with Allegro Solutions:

- **Superior Power Density:** Our "Power-Thru" isolated gate drivers integrate power and isolation into a single package. This removes bulky external components, reducing inverter size and weight to improve bike handling and acceleration.
- **Instant Torque & Precision:** High-bandwidth current and position sensors provide ultra-fast feedback for high-speed motor control. The result is immediate throttle response and smooth delivery, giving riders confidence from launch to highway speeds.
- **Automotive-Grade Safety:** Our ISO 26262 compliant portfolio meets ASIL standards. These sensors and drivers offer built-in diagnostics for critical systems like electronic throttle and BMS, ensuring safety is never compromised.



Riders are increasingly demanding electric motorcycles that offer the thrill of instant torque with zero emissions and low maintenance.

Allegro drives the electric revolution with industry-leading isolated technologies that reduce system weight and complexity. We enable manufacturers to deliver exhilarating performance without compromising safety or reliability.

Block Diagram

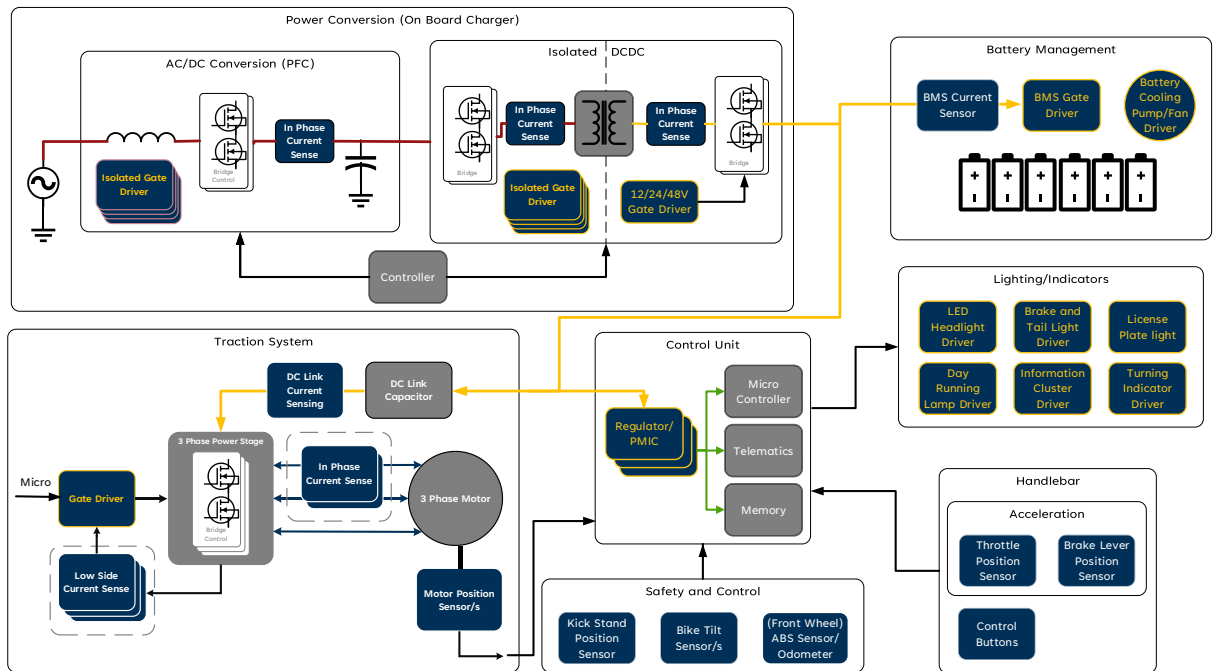

Key Products and Solutions

Subsystem	Component	Allegro Parts	Key Differentiator
Traction System	Inverter (SiC)	AHV85311	Cuts footprint & EMI by eliminating external bias supplies
	Inverter (48V)	AMT49100	Robust ASIL-D driver optimized for 48V traction safety
	Current Sensor	ACS772/3	Ultra-low resistance for cool operation & reinforced isolation
	Motor Position	A33020/2/3	Low latency & immunity for high-RPM efficiency
BMS	Current Sensor	ACS772/3	Precise tracking optimizes range estimation & battery life
Control Unit	PMIC	A4411/2	Stable power for safety MCUs during voltage dips/cranking
On-Board Charger	Isolated Gate Driver	AHV85110	Self-powered driver removes aux supplies in GaN designs
	Current Sensors	ACS71010	Smallest isolated sensor replaces bulky shunts
	Gate Driver	A89500	Fast switching & cross-conduction protection
Handlebar	Throttle & Brake	A31315	3D sensing enables flexible placement & safety compliance
	Control Buttons	APS11203	Rugged protection against heat, reverse battery & transients
Safety	ABS Wheel Speed	A/TS19200	ASIL compliance and integrated EMC protection
	Kick Stand & Tilt	APS11203	Solid-state switches; immune to vibration & dirt
Lighting	Headlight	A6213/7	Flicker-free dimming for premium headlamps
	Backlight	A6263/4	Multi-channel fault detection meets safety regulations
	LCD Bias	A8603	Generates all LCD voltage rails from a single supply
	LCD Backlight	A80601	Noise-free dimming & high sunlight contrast



To learn more about the Allegro family of products and to explore available design resources, visit [allegromicro.com](https://www.allegromicro.com)