

1 MHz, High Accuracy Chopped Current Sensor with Low Output Offset in SOICW-16 Package

FEATURES AND BENEFITS

- High operating bandwidth for fast control loops or where high-speed currents are monitored
 - 1 MHz bandwidth
 - 0.45 μ s typical response time
- High performance for optimized energy applications
 - $\pm 1.5\%$ sensitivity error over temperature (25°C to 125°C)
 - ± 10 mV maximum offset voltage over temperature
 - Ratiometric operation
 - Differential sensing for high immunity to external magnetic fields
 - No magnetic hysteresis
- Adjustable fast overcurrent fault
 - 0.5 μ s typical response time
 - Overcurrent fault available between 50% and 200% full-scale current
- Low internal primary conductor resistance 1 m Ω for better power efficiency
- UL 62368 (edition 3) certification, highly isolated compact SOICW-16 surface mount package
 - 4242 V_{RMS} rated withstand voltage
 - 1000 V_{RMS} / 1414 V_{DC} basic isolation
 - 500 V_{RMS} / 707 V_{DC} reinforced isolation
- High-withstand surge power ratings
- Wide operating temperature, -40°C to 125°C
- AEC-Q100 Grade 1, automotive qualified

PACKAGE: 16-Pin SOICW (suffix LA)

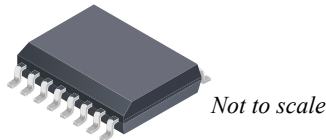

DESCRIPTION

The ACS37035 is a fully integrated Hall-effect current sensor in a SOICW-16 package that is factory-trimmed to provide high accuracy over the entire operating range without the need for customer programming. This sensor provides a compact, fast, and accurate solution for measuring high-frequency currents in a wide array of applications.

The package construction provides high isolation by magnetically coupling the field generated by the current in the conductor to the monolithic Hall sensor IC which has no physical connection to the integrated current conductor. Applied current flowing through the copper conduction path generates a magnetic field that is sensed by the IC and converted to a proportional voltage. Current is sensed differentially in order to reject external common-mode fields. A precise, proportional voltage is provided by the Hall IC.

The ACS37035 offers high bandwidth Hall-effect-based current sensing with a user-configurable overcurrent FAULT detection allowing short-circuit detection for system protection with a fault threshold that is proportional to the current range.

The ACS37035 is suitable for all markets, including automotive, industrial, commercial, and communications systems.

Devices are RoHS compliant and lead (Pb) free with 100% matte-tin-plated leadframes.

APPLICATIONS

- Motor control
- Load detection and management
- Switch-mode power supplies

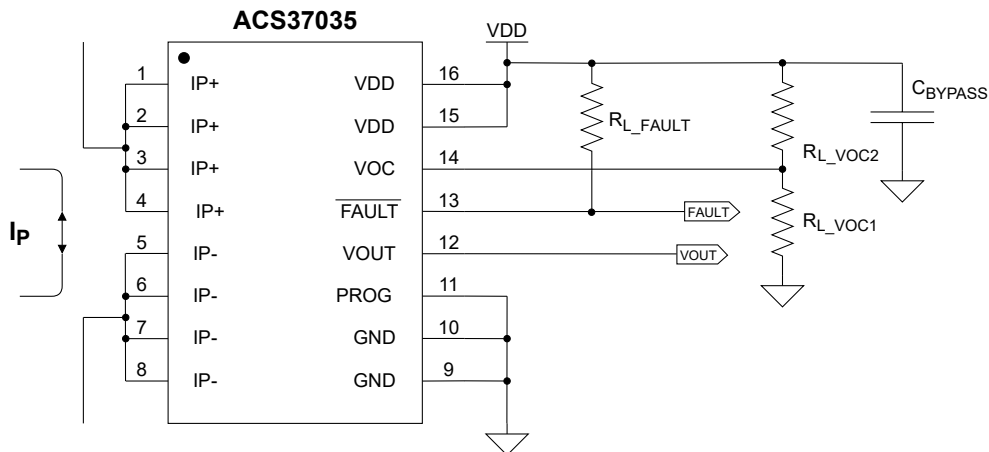

Figure 1: Typical Application Circuit

The device outputs an analog signal at VOUT that varies linearly with the primary current, I_p , within the specified ranges.

SELECTION GUIDE

Part Number	Current Sensing Range (A)	Sensitivity (mV/A)	Supply Voltage V_{DD} (V)	Quiescent Voltage Output V_{QVO} (V)	Optimized Temperature Range T_A (°C)	Packing
ACS37035KLACTR-020B3	±20	66	3.3	$V_{DD}/2$	-40°C to 125°C	1000 pieces per 13-inch reel
ACS37035KLACTR-040B3 ^[1]	±40	33				
ACS37035KLACTR-065B3	±65	20				
ACS37035KLACTR-020B5	±20	100	5			
ACS37035KLACTR-040B5	±40	50				
ACS37035KLACTR-065B5	±65	30				

[1] Pending release.

PART NAMING SPECIFICATION

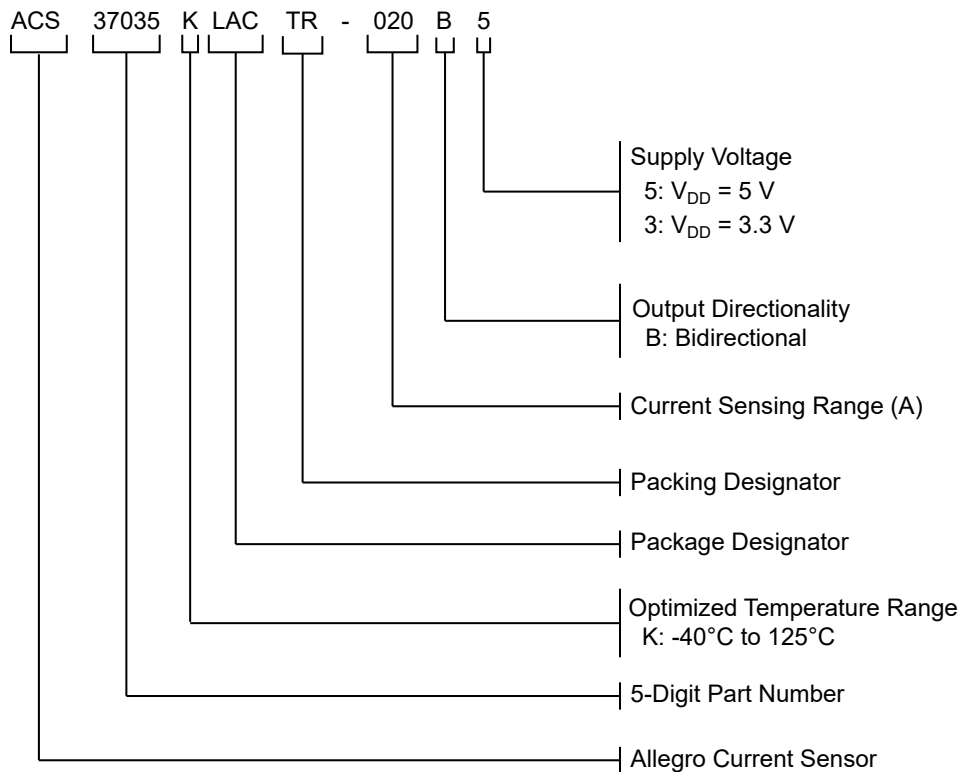

ABSOLUTE MAXIMUM RATINGS [1]

Characteristic	Symbol	Notes	Min.	Max.	Unit
Supply Voltage	V_{DD}		-0.5	6.5	V
Output Voltage	V_O	Applies to VOUT, VOC, and FAULT	-0.5	$(V_{DD} + 0.7) < 6.5$	V
Input Voltage	V_I	Applies to VOC	-0.5	$(V_{DD} + 0.7) < 6.5$	V
Operating Ambient Temperature	T_A		-40	125	°C
Storage Temperature	T_{STG}		-65	165	°C
Maximum Junction Temperature	T_{JMAX}	Sensing range of sensor is limited by $T_{JMAX} = 165^{\circ}\text{C}$	-	165	°C

[1] Stresses above those listed under Absolute Maximum Ratings may cause permanent damage to the device. This is a stress rating only; functional operation of the device at these or any other conditions above those indicated in the operational sections of this specification is not implied. Exposure to absolute maximum ratings for extended periods may affect device reliability.

ISOLATION CHARACTERISTICS

Characteristic	Symbol	Notes	Rating	Unit
Withstand Voltage [1][2]	V_{ISO}	Agency rated for 60 seconds per UL 62368-1 (edition 3)	4242	V_{RMS}
Working Voltage for Basic Isolation [2]	V_{WVBI}	Maximum approved working voltage for basic (single) isolation according to UL 62368-1 (edition 3)	1414	V_{PK} or V_{DC}
			1000	V_{RMS}
Working Voltage for Reinforced Isolation [2]	V_{WVRI}	Maximum approved working voltage for reinforced isolation according to UL 62368-1 (edition 3)	707	V_{PK} or V_{DC}
			500	V_{RMS}
Surge Voltage	V_{SURGE}	1.2/50 μs waveform, tested in dielectric fluid to determine the intrinsic surge immunity of the isolation barrier	10000	V_{PK}
Impulse Voltage	$V_{IMPULSE}$	1.2/50 μs waveform, tested in air	6000	V_{PK}
Clearance	D_{CL}	Minimum distance through air from IP leads to signal leads	8	mm
Creepage	D_{CR}	Minimum distance along package body from IP leads to signal leads	8	mm
Distance Through Insulation	DTI	Minimum internal distance through insulation	59	μm
Comparative Tracking Index	CTI	Material Group II	400 to 599	V

[1] 100% production-tested for 1 second in accordance with UL 62368-1 (edition 3).

[2] Certification pending.

THERMAL CHARACTERISTICS

Characteristic	Symbol	Notes	Value	Unit
Package Thermal Resistance (Junction to Ambient)	$R_{\theta JA}$	Mounted on the standard MA/LA Current Sensor Evaluation Board (ACSEVB-MA16-LA16)	19	°C/W
Package Thermal Metric (Junction to Top)	Ψ_{JT}		0.5	°C/W
Package Thermal Resistance (Junction to Case)	$R_{\theta JC}$	Simulated per the methods in JESD51-1	10	°C/W
Package Thermal Resistance (Junction to Board)	$R_{\theta JB}$	Simulated per the methods in JESD51-8	8	°C/W

PACKAGE CHARACTERISTICS

Characteristic	Symbol	Notes	Min.	Typ.	Max.	Unit
Internal Conductor Resistance	R_{IC}	$T_A = 25^\circ\text{C}$	–	1	–	mΩ
Internal Conductor Inductance	L_{IC}	$T_A = 25^\circ\text{C}$	–	5	–	nH
Moisture Sensitivity Level	MSL	Per IPC/JEDEC J-STD-020	–	3	–	–

PINOUT DIAGRAM AND TERMINAL LIST

Terminal List Table

Number	Name	Description
1, 2, 3, 4	IP+	Positive terminal for current being sensed
5, 6, 7, 8	IP-	Negative terminal for current being sensed
9	GND	Device ground terminal
10	GND	Device ground terminal
11	PROG	Factory calibration terminal, connect to GND for optimal ESD performance
12	VOUT	Analog output signal
13	FAULT	Overcurrent fault output, open-drain, active low
14	VOC	Overcurrent fault operation point analog input
15	VDD	Device power supply terminal
16	VDD	Device power supply terminal

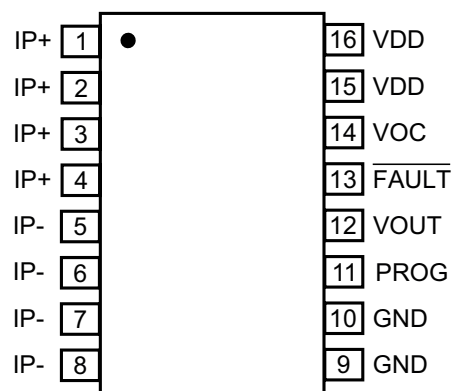

Figure 2: LA Pinout Diagram

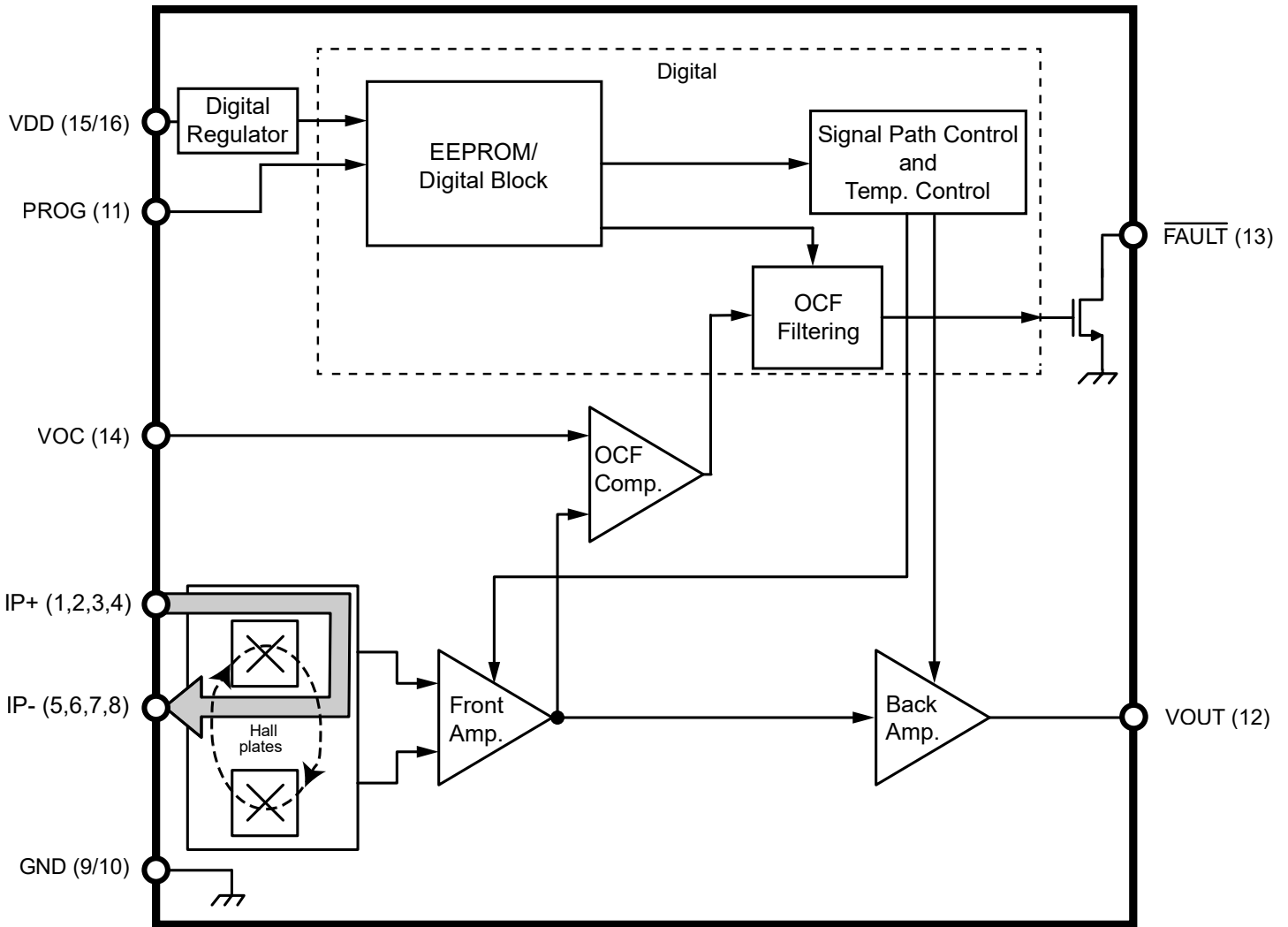

Figure 3: Functional Block Diagram

COMMON ELECTRICAL CHARACTERISTICS: Valid through the full operating temperature range, $T_A = -40^\circ\text{C}$ to 125°C , $C_{\text{BYPASS}} = 0.1\mu\text{F}$, and typical V_{DD} , unless specified otherwise. Minimum and maximum values are tested in production or validated by design and characterization.

Characteristic	Symbol	Test Conditions	Min.	Typ.	Max.	Units
Supply Voltage	V_{DD}	5 V variant	4.5	5	5.5	V
		3.3 V variant	3.0	3.3	3.6	V
Supply Current	I_{CC}	5 V variant, no load on V_{OUT} , $\overline{\text{OCF}}$, and V_{OC}	–	18	30	mA
		3.3 V variant, no load on V_{OUT} , $\overline{\text{OCF}}$, and V_{OC}	–	15	25	mA
Supply Bypass Capacitor	C_{BYPASS}		0.1	–	–	μF
Output Resistive Load [1]	$R_{\text{L_VOUT}}$		10	–	–	k Ω
Output Capacitive Load [1]	$C_{\text{L_VOUT}}$		–	–	1	nF
Power-On Reset Voltage	V_{POR}	$T_A = 25^\circ\text{C}$, V_{DD} rising 1 V/ms	2.6	2.8	2.9	V
Power-On Hysteresis	$V_{\text{POR_HYS}}$		0.2	0.25	–	mV
Power-On Time	t_{PO}		–	–	100	μs
Undervoltage Detection Threshold	V_{UVD}	5 V variant	3.8	4.0	4.2	V
Undervoltage Detection Hysteresis	$V_{\text{UVD_HYS}}$	5 V variant	0.2	0.25	–	V
Undervoltage Delay Time	$t_{\text{UVD_E}}$	5 V variant	60	–	70	μs
	$t_{\text{UVD_D}}$	5 V variant	–	–	10	μs
Overvoltage Detection (OVD) Threshold	$V_{\text{OVD_H}}$	$T_A = 25^\circ\text{C}$, V_{DD} rising 1 V/ms	6	6.2	6.5	V
Overvoltage Detection Hysteresis	$V_{\text{OVD_HYS}}$		0.35	0.45	–	mV
OVD Delay Time	$t_{\text{OVD_E}}$		60	–	70	μs
	$t_{\text{OVD_D}}$		–	–	10	μs
OUTPUT SIGNAL CHARACTERISTICS (VOUT)						
Saturation Voltage [2]	$V_{\text{SAT_H}}$	$R_{\text{L}} = 10\text{ k}\Omega$ to GND	$V_{\text{DD}} - 0.2$	–	–	V
	$V_{\text{SAT_L}}$	$R_{\text{L}} = 10\text{ k}\Omega$ to GND	–	–	0.15	V
Short Circuit Current	$I_{\text{SC_VOUT}}$	VOUT to GND	–	25	50	mA
		VOUT to VDD	–	–25	–50	mA
Bandwidth	BW	Small signal –3 dB, $C_{\text{L_VOUT}} = 1\text{ nF}$	–	1	–	MHz
Rise Time	t_{R}	$T_A = 25^\circ\text{C}$, $C_{\text{L_VOUT}} = 1\text{ nF}$	–	0.45	1	μs
Response Time	t_{RESP}	$T_A = 25^\circ\text{C}$, $C_{\text{L_VOUT}} = 1\text{ nF}$	–	0.45	1	μs
Propagation Delay	t_{PD}	$T_A = 25^\circ\text{C}$, $C_{\text{L_VOUT}} = 1\text{ nF}$	–	0.4	1	μs
Noise Density	N_{D}	5 V variant, $T_A = 25^\circ\text{C}$, $C_{\text{L_VOUT}} = 1\text{ nF}$, 100 mV/A	–	50	–	$\mu\text{A}/\sqrt{\text{Hz}}$
		3.3 V variant, $T_A = 25^\circ\text{C}$, $C_{\text{L_VOUT}} = 1\text{ nF}$, 20 mV/A	–	88	–	$\mu\text{A}/\sqrt{\text{Hz}}$
Noise	N	5 V variant, $T_A = 25^\circ\text{C}$, $C_{\text{L_VOUT}} = 1\text{ nF}$, 100 mV/A	–	63	–	mA_{RMS}
		3.3 V variant, $T_A = 25^\circ\text{C}$, $C_{\text{L_VOUT}} = 1\text{ nF}$, 20 mV/A	–	110	–	mA_{RMS}
Common-Mode Field Rejection	CMFR	Input-referred error due to common-mode field	–	4	–	mA/G
VOUT Output Resistance	R_{O}		–	7.3	–	Ω

[1] Validated by design and characterization.

[2] The sensor may continue to respond to current beyond the specified Current Sensing Range, I_{PR} , until the output saturates at the high or low saturation voltage; however, the linearity and sensitivity error beyond the specified Current Sensing Range are not validated.

OVERCURRENT CHARACTERISTICS: Valid through the full operating temperature range, $T_A = -40^\circ\text{C}$ to 125°C , $C_{\text{BYPASS}} = 0.1 \mu\text{F}$, and typical V_{DD} , unless specified otherwise. Minimum and maximum values are tested in production or validated by design and characterization.

Characteristic	Symbol	Test Conditions	Min.	Typ.	Max.	Unit
Overcurrent FAULT Threshold Range	I_{OCR}		50	–	200	$\%I_{\text{PR}}$
Overcurrent FAULT Pull-Up Resistor	$R_{\text{L_FAULT}}$		10	–	500	$\text{k}\Omega$
Overcurrent Error	E_{OC}		–10	–	10	$\%I_{\text{OC}}$ [2]
FAULT Output Low Voltage	$V_{\text{FAULT_L}}$	$R_{\text{L_FAULT}} = 10 \text{ k}\Omega$, fault condition present	–	–	0.4	V
FAULT Leakage Current	$I_{\text{FAULT_OFF}}$	$R_{\text{L_FAULT}} = 10 \text{ k}\Omega$, no fault condition present	–	–	1	μA
Overcurrent Response Time [1]	$t_{\text{OC_RESP}}$	$T_A = 25^\circ\text{C}$, $R_{\text{L_FAULT}} = 10 \text{ k}\Omega$	–	0.5	0.75	μs
VOC Input Linear Operating Range	$V_{\text{OR_VOC}}$		$0.1 \times V_{\text{DD}}$	–	$0.4 \times V_{\text{DD}}$	V
VOC Input Current	I_{VOC}		–	–	1	μA

[1] Validated by design and characterization.

[2] Where I_{OC} is the specific point at which the OCF trigger will occur and is set by V_{VOC} voltage within $V_{\text{OR_VOC}}$.

ACS37035KLACTR-020B3 PERFORMANCE CHARACTERISTICS: Valid through the full operating temperature range, $T_A = -40^\circ\text{C}$ to 125°C , $C_{\text{BYPASS}} = 0.1 \mu\text{F}$, and typical V_{DD} , unless specified otherwise. Minimum and maximum values are tested in production or validated by design and characterization.

Characteristic	Symbol	Test Conditions	Min. [1]	Typ.	Max. [1]	Unit
NOMINAL PERFORMANCE						
Current Sensing Range [2]	I_{PR}	Limited by $T_{\text{J(MAX)}} = 165^\circ\text{C}$	-20	-	20	A
Sensitivity	Sens	$I_{\text{PR(min)}} < I_{\text{P}} < I_{\text{PR(max)}}$	-	66	-	mV/A
Quiescent Voltage Output	V_{QVO}	$I_{\text{P}} = 0 \text{ A}$	-	$0.5 \times V_{\text{DD}}$	-	V
Overcurrent FAULT Hysteresis	$I_{\text{OC_HYS}}$		-	2.4	-	A
FAULT ERROR						
Overcurrent Fault Error	$I_{\text{OC_E}}$		-2	-	2	A
ERROR COMPONENTS						
Sensitivity Error	E_{SENS}	$I_{\text{P}} = I_{\text{PR(max)}}$, $T_A = 25^\circ\text{C}$ to 125°C	-1.5	-	1.5	%
		$I_{\text{P}} = I_{\text{PR(max)}}$, $T_A = -40^\circ\text{C}$ to 25°C	-3	-	3	%
Quiescent Voltage Output Error	$V_{\text{QVO_E}}$	$I_{\text{P}} = 0 \text{ A}$, $T_A = 25^\circ\text{C}$ to 125°C	-10	-	10	mV
		$I_{\text{P}} = 0 \text{ A}$, $T_A = -40^\circ\text{C}$ to 25°C	-15	-	15	mV
Noise	N	$T_A = 25^\circ\text{C}$, $C_{\text{L_VOUT}} = 1 \text{ nF}$, $\text{BW} = 1 \text{ MHz}$	-	6.1	-	mV_{RMS}
		$T_A = 125^\circ\text{C}$, $C_{\text{L_VOUT}} = 1 \text{ nF}$, $\text{BW} = 1 \text{ MHz}$	-	12.5	-	mV_{RMS}
Sensitivity Ratiometry Error	$E_{\text{SENS_RAT}}$	$V_{\text{DD(typ)}} \pm 5\%$	-2	-	2	%
Quiescent Voltage Output Ratiometry Error	$V_{\text{QVO_RAT}}$	$V_{\text{DD(typ)}} \pm 5\%$	-12	-	12	mV
Output Voltage Ripple [3]	V_{RIPPLE}	$T_A = 25^\circ\text{C}$, $f = 2.5 \text{ MHz}$	-	15	-	mV_{PP}
LIFETIME DRIFT [2]						
Sensitivity Drift Over Lifetime	$E_{\text{SENS_LT}}$	Based on the mean drift of worst-case distribution observed after AEC-Q100 qualification stresses	-	0.5	-	%
Quiescent Voltage Drift Over Lifetime	$V_{\text{QVO_LT}}$	Based on the mean drift of worst-case distribution observed after AEC-Q100 qualification stresses	-	2.2	-	mV

[1] Absolute minimum ("Min." or "min") and absolute maximum ("Max." or "max") are the production limits that the device must not exceed.

[2] Validated by design and characterization.

[3] The output may display residual chopping frequency as a ripple at 2.5 MHz.

ACS37035KLACTR-040B3 PERFORMANCE CHARACTERISTICS: Valid through the full operating temperature range, $T_A = -40^\circ\text{C}$ to 125°C , $C_{\text{BYPASS}} = 0.1 \mu\text{F}$, and typical V_{DD} , unless specified otherwise. Minimum and maximum values are tested in production or validated by design and characterization.

Characteristic	Symbol	Test Conditions	Min. [1]	Typ.	Max. [1]	Unit
NOMINAL PERFORMANCE						
Current Sensing Range [2]	I_{PR}	Limited by $T_{\text{J(MAX)}} = 165^\circ\text{C}$	-40	-	40	A
Sensitivity	Sens	$I_{\text{PR(min)}} < I_{\text{P}} < I_{\text{PR(max)}}$	-	33	-	mV/A
Quiescent Voltage Output	V_{QVO}	$I_{\text{P}} = 0 \text{ A}$	-	$0.5 \times V_{\text{DD}}$	-	V
Overcurrent FAULT Hysteresis	$I_{\text{OC_HYS}}$		-	5.2	-	A
FAULT ERROR						
Overcurrent Fault Error	$I_{\text{OC_E}}$		-4	-	4	A
ERROR COMPONENTS						
Sensitivity Error	E_{SENS}	$I_{\text{P}} = I_{\text{PR(max)}}$, $T_A = 25^\circ\text{C}$ to 125°C	-1.5	-	1.5	%
		$I_{\text{P}} = I_{\text{PR(max)}}$, $T_A = -40^\circ\text{C}$ to 25°C	-3	-	3	%
Quiescent Voltage Output Error	$V_{\text{QVO_E}}$	$I_{\text{P}} = 0 \text{ A}$, $T_A = 25^\circ\text{C}$ to 125°C	-10	-	10	mV
		$I_{\text{P}} = 0 \text{ A}$, $T_A = -40^\circ\text{C}$ to 25°C	-15	-	15	mV
Noise	N	$T_A = 25^\circ\text{C}$, $C_{\text{L_VOUT}} = 1 \text{ nF}$, $\text{BW} = 1 \text{ MHz}$	-	3.2	-	mV_{RMS}
		$T_A = 125^\circ\text{C}$, $C_{\text{L_VOUT}} = 1 \text{ nF}$, $\text{BW} = 1 \text{ MHz}$	-	6.1	-	mV_{RMS}
Sensitivity Ratiometry Error	$E_{\text{SENS_RAT}}$	$V_{\text{DD(typ)}} \pm 5\%$	-2	-	2	%
Quiescent Voltage Output Ratiometry Error	$V_{\text{QVO_RAT}}$	$V_{\text{DD(typ)}} \pm 5\%$	-12	-	12	mV
Output Voltage Ripple [3]	V_{RIPPLE}	$T_A = 25^\circ\text{C}$, $f = 2.5 \text{ MHz}$	-	8	-	mV_{PP}
LIFETIME DRIFT [2]						
Sensitivity Drift Over Lifetime	$E_{\text{SENS_LT}}$	Based on the mean drift of worst-case distribution observed after AEC-Q100 qualification stresses	-	0.5	-	%
Quiescent Voltage Drift Over Lifetime	$V_{\text{QVO_LT}}$	Based on the mean drift of worst-case distribution observed after AEC-Q100 qualification stresses	-	2.2	-	mV

[1] Absolute minimum ("Min." or "min") and absolute maximum ("Max." or "max") are the production limits that the device must not exceed.

[2] Validated by design and characterization.

[3] The output may display residual chopping frequency as a ripple at 2.5 MHz.

ACS37035KLACTR-065B3 PERFORMANCE CHARACTERISTICS: Valid through the full operating temperature range, $T_A = -40^\circ\text{C}$ to 125°C , $C_{\text{BYPASS}} = 0.1 \mu\text{F}$, and typical V_{DD} , unless specified otherwise. Minimum and maximum values are tested in production or validated by design and characterization.

Characteristic	Symbol	Test Conditions	Min. [1]	Typ.	Max. [1]	Unit
NOMINAL PERFORMANCE						
Current Sensing Range [2]	I_{PR}	Limited by $T_{\text{J(MAX)}} = 165^\circ\text{C}$	-65	-	65	A
Sensitivity	Sens	$I_{\text{PR(min)}} < I_{\text{P}} < I_{\text{PR(max)}}$	-	20	-	mV/A
Quiescent Voltage Output	V_{QVO}	$I_{\text{P}} = 0 \text{ A}$	-	$0.5 \times V_{\text{DD}}$	-	V
Overcurrent FAULT Hysteresis	$I_{\text{OC_HYS}}$		-	4.8	-	A
FAULT ERROR						
Overcurrent Fault Error	$I_{\text{OC_E}}$		-6.5	-	6.5	A
ERROR COMPONENTS						
Sensitivity Error	E_{SENS}	$I_{\text{P}} = I_{\text{PR(max)}}$, $T_A = 25^\circ\text{C}$ to 125°C	-1.5	-	1.5	%
		$I_{\text{P}} = I_{\text{PR(max)}}$, $T_A = -40^\circ\text{C}$ to 25°C	-3	-	3	%
Quiescent Voltage Output Error	$V_{\text{QVO_E}}$	$I_{\text{P}} = 0 \text{ A}$, $T_A = 25^\circ\text{C}$ to 125°C	-10	-	10	mV
		$I_{\text{P}} = 0 \text{ A}$, $T_A = -40^\circ\text{C}$ to 25°C	-15	-	15	mV
Noise	N	$T_A = 25^\circ\text{C}$, $C_{\text{L_VOUT}} = 1 \text{ nF}$, $\text{BW} = 1 \text{ MHz}$	-	2.2	-	mV_{RMS}
		$T_A = 125^\circ\text{C}$, $C_{\text{L_VOUT}} = 1 \text{ nF}$, $\text{BW} = 1 \text{ MHz}$	-	4.2	-	mV_{RMS}
Sensitivity Ratiometry Error	$E_{\text{SENS_RAT}}$	$V_{\text{DD(typ)}} \pm 5\%$	-2	-	2	%
Quiescent Voltage Output Ratiometry Error	$V_{\text{QVO_RAT}}$	$V_{\text{DD(typ)}} \pm 5\%$	-12	-	12	mV
Output Voltage Ripple [3]	V_{RIPPLE}	$T_A = 25^\circ\text{C}$, $f = 2.5 \text{ MHz}$	-	3	-	mV_{PP}
LIFETIME DRIFT [2]						
Sensitivity Drift Over Lifetime	$E_{\text{SENS_LT}}$	Based on the mean drift of worst-case distribution observed after AEC-Q100 qualification stresses	-	0.5	-	%
Quiescent Voltage Drift Over Lifetime	$V_{\text{QVO_LT}}$	Based on the mean drift of worst-case distribution observed after AEC-Q100 qualification stresses	-	2.2	-	mV

[1] Absolute minimum ("Min." or "min") and absolute maximum ("Max." or "max") are the production limits that the device must not exceed.

[2] Validated by design and characterization.

[3] The output may display residual chopping frequency as a ripple at 2.5 MHz.

ACS37035KLACTR-020B5 PERFORMANCE CHARACTERISTICS: Valid through the full operating temperature range, $T_A = -40^\circ\text{C}$ to 125°C , $C_{\text{BYPASS}} = 0.1 \mu\text{F}$, and typical V_{DD} , unless specified otherwise. Minimum and maximum values are tested in production or validated by design and characterization.

Characteristic	Symbol	Test Conditions	Min. [1]	Typ.	Max. [1]	Unit
NOMINAL PERFORMANCE						
Current Sensing Range [2]	I_{PR}	Limited by $T_{\text{J(MAX)}} = 165^\circ\text{C}$	-20	-	20	A
Sensitivity	Sens	$I_{\text{PR(min)}} < I_{\text{P}} < I_{\text{PR(max)}}$	-	100	-	mV/A
Quiescent Voltage Output	V_{QVO}	$I_{\text{P}} = 0 \text{ A}$	-	$0.5 \times V_{\text{DD}}$	-	V
Overcurrent FAULT Hysteresis	$I_{\text{OC_HYS}}$		-	1.5	-	A
FAULT ERROR						
Overcurrent Fault Error	$I_{\text{OC_E}}$		-2	-	2	A
ERROR COMPONENTS						
Sensitivity Error	E_{SENS}	$I_{\text{P}} = I_{\text{PR(max)}}$, $T_A = 25^\circ\text{C}$ to 125°C	-1.5	-	1.5	%
		$I_{\text{P}} = I_{\text{PR(max)}}$, $T_A = -40^\circ\text{C}$ to 25°C	-3	-	3	%
Quiescent Voltage Output Error	$V_{\text{QVO_E}}$	$I_{\text{P}} = 0 \text{ A}$, $T_A = 25^\circ\text{C}$ to 125°C	-10	-	10	mV
		$I_{\text{P}} = 0 \text{ A}$, $T_A = -40^\circ\text{C}$ to 25°C	-15	-	15	mV
Noise	N	$T_A = 25^\circ\text{C}$, $C_{\text{L_VOOUT}} = 1 \text{ nF}$, $\text{BW} = 1 \text{ MHz}$	-	6.3	-	mV_{RMS}
		$T_A = 125^\circ\text{C}$, $C_{\text{L_VOOUT}} = 1 \text{ nF}$, $\text{BW} = 1 \text{ MHz}$	-	12.5	-	mV_{RMS}
Sensitivity Ratiometry Error	$E_{\text{SENS_RAT}}$	$V_{\text{DD(typ)}} \pm 5\%$	-2	-	2	%
Quiescent Voltage Output Ratiometry Error	$V_{\text{QVO_RAT}}$	$V_{\text{DD(typ)}} \pm 5\%$	-12	-	12	mV
Output Voltage Ripple [3]	V_{RIPPLE}	$T_A = 25^\circ\text{C}$, $f = 2.5 \text{ MHz}$	-	17	-	mV_{PP}
LIFETIME DRIFT [2]						
Sensitivity Drift Over Lifetime	$E_{\text{SENS_LT}}$	Based on the mean drift of worst-case distribution observed after AEC-Q100 qualification stresses	-	0.5	-	%
Quiescent Voltage Drift Over Lifetime	$V_{\text{QVO_LT}}$	Based on the mean drift of worst-case distribution observed after AEC-Q100 qualification stresses	-	2.2	-	mV

[1] Absolute minimum ("Min." or "min") and absolute maximum ("Max." or "max") are the production limits that the device must not exceed.

[2] Validated by design and characterization.

[3] The output may display residual chopping frequency as a ripple at 2.5 MHz.

ACS37035KLACTR-040B5 PERFORMANCE CHARACTERISTICS: Valid through the full operating temperature range, $T_A = -40^\circ\text{C}$ to 125°C , $C_{\text{BYPASS}} = 0.1 \mu\text{F}$, and typical V_{DD} , unless specified otherwise. Minimum and maximum values are tested in production or validated by design and characterization.

Characteristic	Symbol	Test Conditions	Min. [1]	Typ.	Max. [1]	Unit
NOMINAL PERFORMANCE						
Current Sensing Range [2]	I_{PR}	Limited by $T_{\text{J(MAX)}} = 165^\circ\text{C}$	-40	-	40	A
Sensitivity	Sens	$I_{\text{PR(min)}} < I_{\text{P}} < I_{\text{PR(max)}}$	-	50	-	mV/A
Quiescent Voltage Output	V_{QVO}	$I_{\text{P}} = 0 \text{ A}$	-	$0.5 \times V_{\text{DD}}$	-	V
Overcurrent FAULT Hysteresis	$I_{\text{OC_HYS}}$		-	2.8	-	A
FAULT ERROR						
Overcurrent Fault Error	$I_{\text{OC_E}}$		-4	-	4	A
ERROR COMPONENTS						
Sensitivity Error	E_{SENS}	$I_{\text{P}} = I_{\text{PR(max)}}$, $T_A = 25^\circ\text{C}$ to 125°C	-1.5	-	1.5	%
		$I_{\text{P}} = I_{\text{PR(max)}}$, $T_A = -40^\circ\text{C}$ to 25°C	-3	-	3	%
Quiescent Voltage Output Error	$V_{\text{QVO_E}}$	$I_{\text{P}} = 0 \text{ A}$, $T_A = 25^\circ\text{C}$ to 125°C	-10	-	10	mV
		$I_{\text{P}} = 0 \text{ A}$, $T_A = -40^\circ\text{C}$ to 25°C	-15	-	15	mV
Noise	N	$T_A = 25^\circ\text{C}$, $C_L = 1 \text{ nF}$, $\text{BW} = 1 \text{ MHz}$	-	3.4	-	mV_{RMS}
		$T_A = 125^\circ\text{C}$, $C_L = 1 \text{ nF}$, $\text{BW} = 1 \text{ MHz}$	-	6.6	-	mV_{RMS}
Sensitivity Ratiometry Error	$E_{\text{SENS_RAT}}$	$V_{\text{DD(typ)}} \pm 5\%$	-2	-	2	%
Quiescent Voltage Output Ratiometry Error	$V_{\text{QVO_RAT}}$	$V_{\text{DD(typ)}} \pm 5\%$	-12	-	12	mV
Output Voltage Ripple [3]	V_{RIPPLE}	$T_A = 25^\circ\text{C}$, $f = 2.5 \text{ MHz}$	-	7.4	-	mV_{PP}
LIFETIME DRIFT [2]						
Sensitivity Drift Over Lifetime	$E_{\text{SENS_LT}}$	Based on the mean drift of worst-case distribution observed after AEC-Q100 qualification stresses	-	0.5	-	%
Quiescent Voltage Drift Over Lifetime	$V_{\text{QVO_LT}}$	Based on the mean drift of worst-case distribution observed after AEC-Q100 qualification stresses	-	2.2	-	mV

[1] Absolute minimum ("Min." or "min") and absolute maximum ("Max." or "max") are the production limits that the device must not exceed.

[2] Validated by design and characterization.

[3] The output may display residual chopping frequency as a ripple at 2.5 MHz.

ACS37035KLACTR-065B5 PERFORMANCE CHARACTERISTICS: Valid through the full operating temperature range, $T_A = -40^\circ\text{C}$ to 125°C , $C_{\text{BYPASS}} = 0.1 \mu\text{F}$, and typical V_{DD} , unless specified otherwise. Minimum and maximum values are tested in production or validated by design and characterization.

Characteristic	Symbol	Test Conditions	Min. [1]	Typ.	Max. [1]	Unit
NOMINAL PERFORMANCE						
Current Sensing Range [2]	I_{PR}	Limited by $T_{\text{J(MAX)}} = 165^\circ\text{C}$	-65	-	65	A
Sensitivity	Sens	$I_{\text{PR(min)}} < I_{\text{P}} < I_{\text{PR(max)}}$	-	30	-	mV/A
Quiescent Voltage Output	V_{QVO}	$I_{\text{P}} = 0 \text{ A}$	-	$0.5 \times V_{\text{DD}}$	-	V
Overcurrent FAULT Hysteresis	$I_{\text{OC_HYS}}$		-	5.0	-	A
FAULT ERROR						
Overcurrent Fault Error	$I_{\text{OC_E}}$		-6.5	-	6.5	A
ERROR COMPONENTS						
Sensitivity Error	E_{SENS}	$I_{\text{P}} = I_{\text{PR(max)}}$, $T_A = 25^\circ\text{C}$ to 125°C	-1.5	-	1.5	%
		$I_{\text{P}} = I_{\text{PR(max)}}$, $T_A = -40^\circ\text{C}$ to 25°C	-3	-	3	%
Quiescent Voltage Output Error	$V_{\text{QVO_E}}$	$I_{\text{P}} = 0 \text{ A}$, $T_A = 25^\circ\text{C}$ to 125°C	-10	-	10	mV
		$I_{\text{P}} = 0 \text{ A}$, $T_A = -40^\circ\text{C}$ to 25°C	-15	-	15	mV
Noise	N	$T_A = 25^\circ\text{C}$, $C_{\text{L}} = 1 \text{ nF}$, $\text{BW} = 1 \text{ MHz}$	-	2.4	-	mV_{RMS}
		$T_A = 125^\circ\text{C}$, $C_{\text{L}} = 1 \text{ nF}$, $\text{BW} = 1 \text{ MHz}$	-	4.3	-	mV_{RMS}
Sensitivity Ratiometry Error	$E_{\text{SENS_RAT}}$	$V_{\text{DD(typ)}} \pm 5\%$	-2	-	2	%
Quiescent Voltage Output Ratiometry Error	$V_{\text{QVO_RAT}}$	$V_{\text{DD(typ)}} \pm 5\%$	-12	-	12	mV
Output Voltage Ripple [3]	V_{RIPPLE}	$T_A = 25^\circ\text{C}$, $f = 2.5 \text{ MHz}$	-	2.3	-	mV_{PP}
LIFETIME DRIFT [2]						
Sensitivity Drift Over Lifetime	$E_{\text{SENS_LT}}$	Based on the mean drift of worst-case distribution observed after AEC-Q100 qualification stresses	-	0.5	-	%
Quiescent Voltage Drift Over Lifetime	$V_{\text{QVO_LT}}$	Based on the mean drift of worst-case distribution observed after AEC-Q100 qualification stresses	-	2.2	-	mV

[1] Absolute minimum ("Min." or "min") and absolute maximum ("Max." or "max") are the production limits that the device must not exceed.

[2] Validated by design and characterization.

[3] The output may display residual chopping frequency as a ripple at 2.5 MHz.

DESCRIPTIONS OF POWER ON/OFF OPERATION

Introduction

To ensure that the device output is reporting accurately, the sensors contains an overvoltage and an undervoltage detection flag (undervoltage detection is enabled on 5 V device). This internal flag on V_{OUT} can be used to alert the system when the supply voltage for the device is outside of the operational range by putting the output into a known high-impedance (high Z) state.

The provided graphs in this section show V_{OUT} moving with V_{DD} . The voltage of V_{OUT} during a high-impedance state will be most consistent with a known load (R_{L_VOUT} , C_{L_VOUT}). All figures below all use the same labeling scheme for different power thresholds. References in brackets “[]” are valid for Figure 5, Figure 4, and Figure 6.

POWER-ON OPERATION

As V_{DD} ramps up, the V_{OUT} pin is high Z until V_{DD} reaches and passes V_{UVD} [2]. Once V_{DD} passes [2], the device takes some time without V_{DD} dropping below $V_{POR} - V_{POR_HYS}$ [8] before the device enters normal operation.

POWER-OFF OPERATION

Before the device powers off, it will force V_{OUT} to GND if V_{DD} reaches less than $V_{UVD} - V_{UVD_HYS}$ [6]. When $V_{POR} - V_{POR_HYS}$ [8] is reached, V_{OUT} will go high Z.

NOTE: Because the device is entering a high Z state and not driving the output, the time it takes the output to reach a steady state will depend on the external circuitry used.

POWER-ON RESET VOLTAGE (V_{POR})

If V_{DD} falls below $V_{POR} - V_{POR_HYS}$ [8] while in operation, the digital circuitry turns off and the output will re-enter a high Z state. After V_{DD} recovers and exceeds V_{UVD} [2], the output will begin reporting again after the delay of t_{PO} .

UNDERVOLTAGE DETECTION THRESHOLD (V_{UVD})

The 5 V devices are factory-programmed with UVD. It is important to note that, when powering up the device for the first time after a Power-On Reset event, V_{OUT} will remain high Z until V_{DD} is raised above V_{UVD} [2], at which point the V_{OUT} output will begin to resume normal operation. If it is a 3.3 V device, V_{OUT} will begin normal operation after V_{DD} rises above V_{POR} [1] under the same conditions.

If V_{DD} drops below $V_{UVD} - V_{UVD_HYS}$ [6] after normal operation, V_{OUT} will pull to GND regardless of R_{L_VOUT} configuration. The V_{OUT} will remain at GND until V_{DD} rises above V_{UVD} [7] or V_{DD} falls below $V_{POR} - V_{POR_HYS}$ [8]. If V_{DD} rises above V_{UVD} [7] after a UVD event, the V_{OUT} output will resume operation. If V_{DD} drops below $V_{PO} - V_{POR_HYS}$ [8], the device will enter a POR event and reset; V_{OUT} will switch to high Z if this occurs.

OVERVOLTAGE DETECTION THRESHOLD (V_{OVD})

When V_{DD} rises above V_{OVD} [4], the output of the V_{OUT} pin will go high Z and will be pulled to either VDD or GND, depending on the configuration (pull-up vs. pull-down) of R_{L_VOUT} .

OVERVOLTAGE/UNDERVOLTAGE DETECTION HYSTERESIS (V_{OVD_HYS} , V_{UVD_HYS})

There is hysteresis between enable and disable thresholds to reduce nuisance flagging and clears.

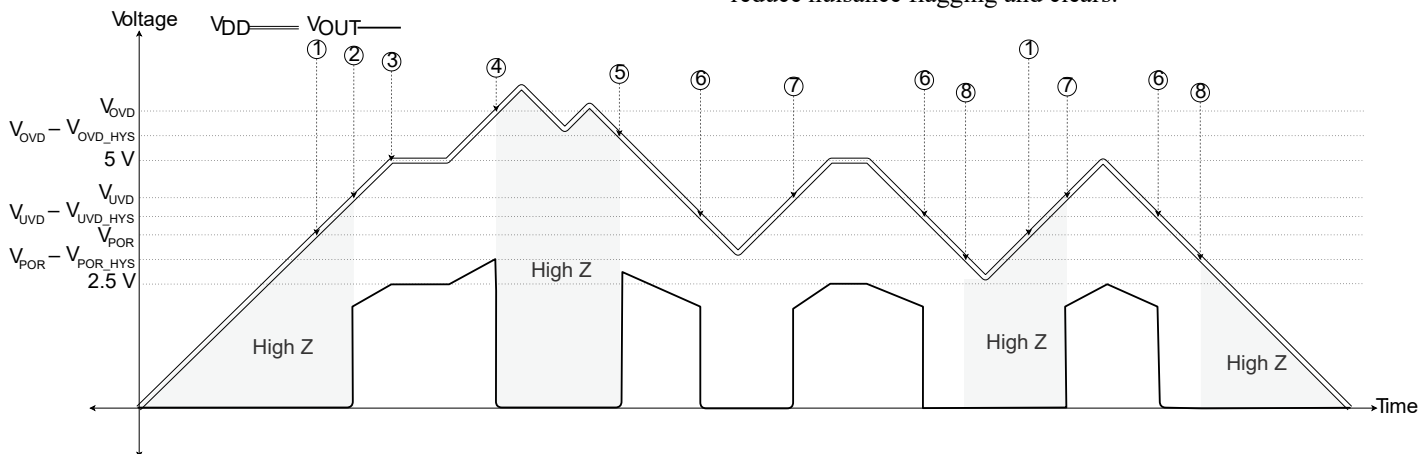

Figure 4: Power States Thresholds with V_{OUT} Behavior for a 5 V Device, $R_{L_VOUT} =$ Pull-Down

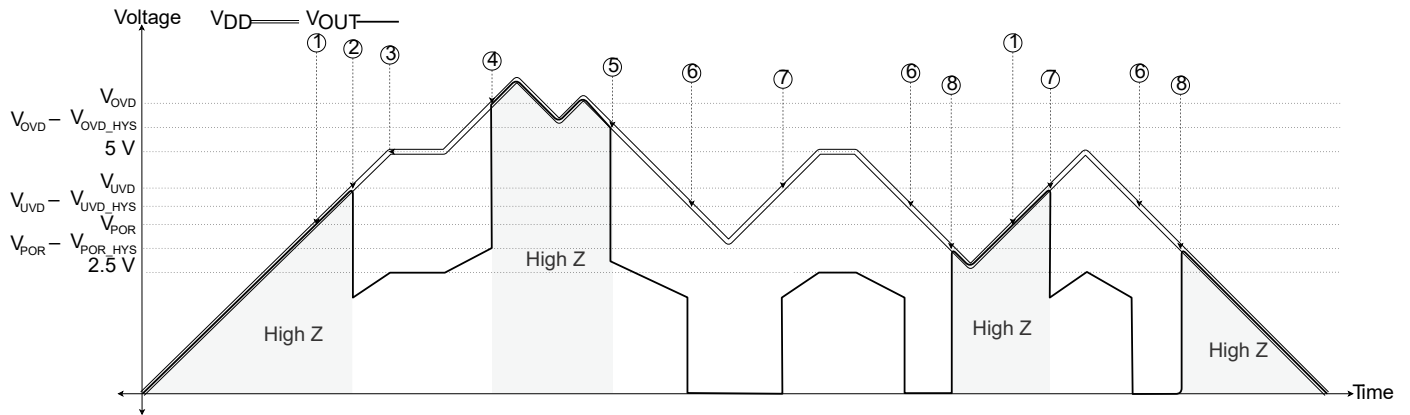

Figure 5: Power States Thresholds with V_{OUT} Behavior, 5 V Device, R_{L_VOUT} = Pull-Up

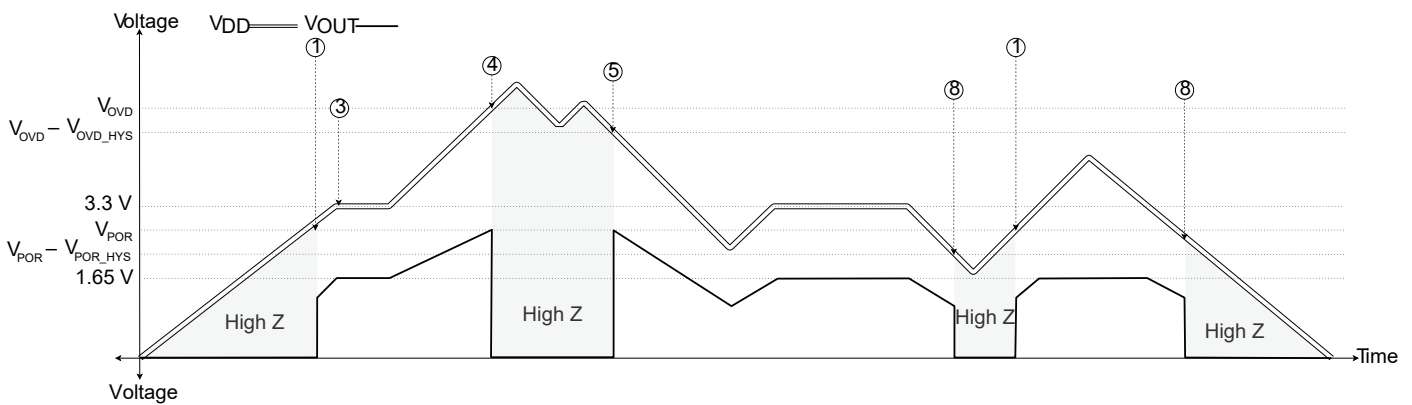

Figure 6: Power States Thresholds with V_{OUT} Behavior, 3.3 V Device, R_L = Pull-Down, UVD Disabled

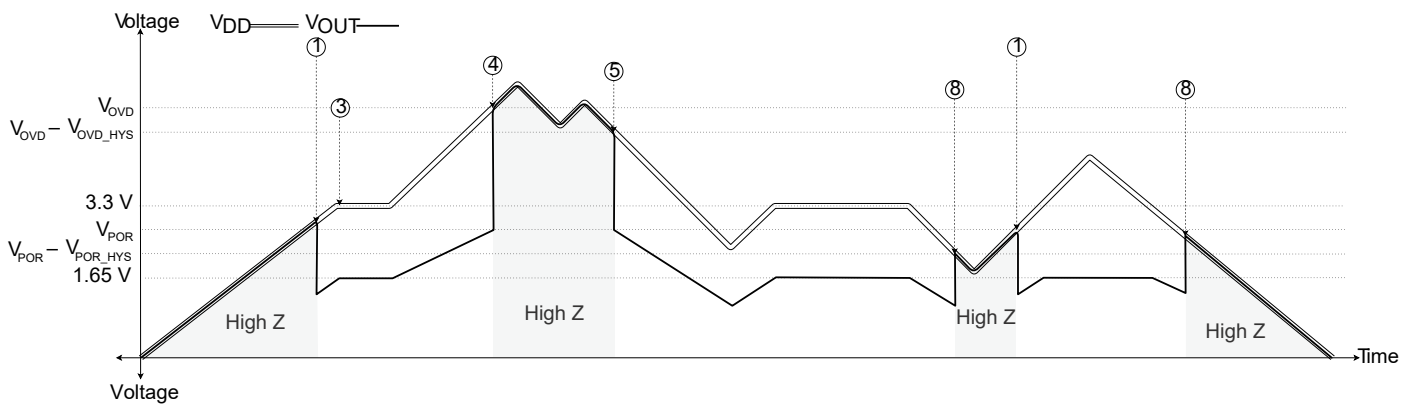

Figure 7: Power States Thresholds with V_{OUT} Behavior, 3.3 V Device, R_L = Pull-Up, UVD Disabled

DESCRIPTIONS OF TIMING THRESHOLDS

POWER-ON DELAY (t_{PO})

When the supply is ramped to V_{UVD} [2], the device will require a finite time to power its internal components before the outputs are released from high Z and can respond to an input magnetic field. Power-On Time, t_{PO} , is defined as the time it takes for the output voltage to settle within $\pm 10\%$ of its steady-state value under an applied magnetic field, which can be seen as the time from [2] to [A] in Figure 8. After this delay, the output will quickly approach $V_{OUT(IP)} = Sens \times I_p + V_{QVO}$.

OVERVOLTAGE AND UNDERVOLTAGE DETECTION TIME AND DETECTION RELEASE TIME

(t_{OVD_E}/t_{OVD_D} , t_{UVD_E}/t_{UVD_D})

The enable time for OVD, t_{OVD_E} , is the time from V_{OVD} [4] to OVD flag [B]. The UVD enable time, t_{UVD_E} , is the time from $V_{UVD} - V_{UVD_HYS}$ [6] to the UVD flag [D].

If V_{DD} ramps from $>V_{UVD} - V_{UVD_HYS}$ [6] to $<V_{POR} - V_{POR_HYS}$ [8] faster than t_{UVD_E} , then the device will not have time to report a UVD event before power off occurs.

The detection release time for OVD, t_{OVD_R} , is the time from $V_{OVD} - V_{OVD_HYS}$ [5] to the OVD clear to normal operation [C]. The UVD disable time, t_{UVD_R} , is the time from V_{UVD} [7] to the point that the UVD flag clears and V_{OUT} returns to nominal operation [E]. The disable time does not have a counter for either OVD or UVD to release the output and resume reporting.

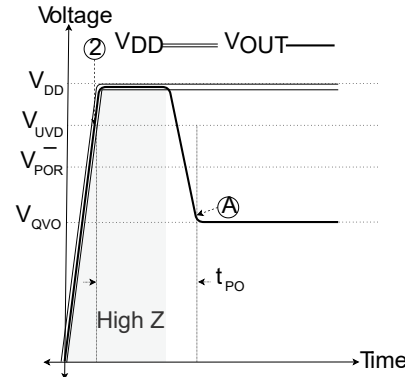

Figure 8: t_{PO} behavior UVD enabled, $R_{L_VOUT} = Pull-Up$

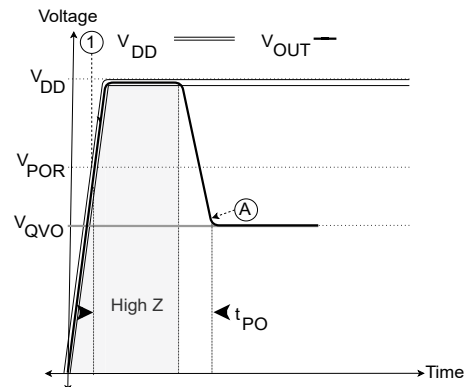

Figure 9: t_{PO} behavior UVD disabled, $R_{L_VOUT} = Pull-Up$

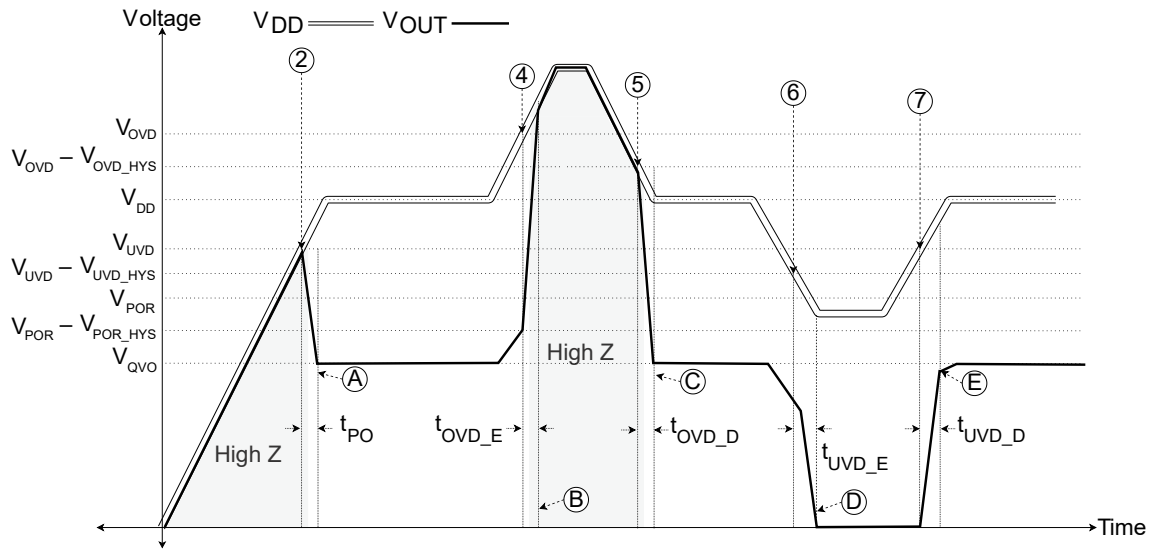

Figure 10: t_{PO} , and t_{OVD}/t_{OVD_R} , and t_{UVD}/t_{UVD_R} with $R_{L_VOUT} = \text{Pull-Up}, 5\text{ V}$

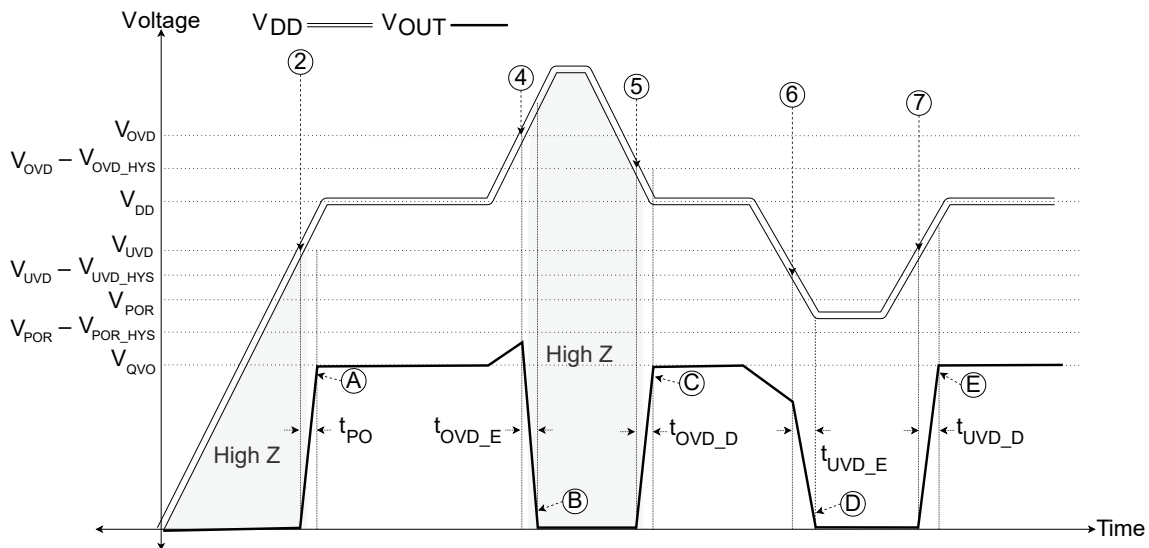

Figure 11: t_{PO} , and t_{OVD}/t_{OVD_R} , and t_{UVD}/t_{UVD_R} with $R_{L_VOUT} = \text{Pull-Down}, 5\text{ V}$

DEFINITIONS OF OPERATING AND PERFORMANCE CHARACTERISTICS

Quiescent Voltage Output (V_{QVO})

Quiescent Voltage Output, V_{QVO}, is defined as the voltage on the output, V_{OUT}, when no current is applied, I_p = 0.

$$V_{QVO} = V_{OUT_@0A} [mV]$$

Quiescent Voltage Output Error (V_{QVO_E})

Quiescent Voltage Output Error, V_{QVO_E}, is defined as the deviation of V_{QVO} from the nominal target value in production testing.

$$V_{QVO_E} = V_{QVO_MEASURED} - V_{QVO_IDEAL} [mV]$$

Quiescent Voltage Output Ratiometry Error (V_{OE_RAT})

Ratiometric error for quiescent voltage output is calculated using the following equation:

$$V_{QVO_RAT} = V_{QVO(VDD)} - V_{QVO(VDDN)} \times \frac{V_{DD}}{V_{DD(N)}} [mV]$$

where V_{DD(N)} is equal to the nominal V_{DD} (3.3 V, or 5 V) and V_{QVO(VCCN)} is the measured offset voltage at the nominal V_{DD} for a particular device. The symbol V_{DD} is the measured V_{DD} value in application and V_{QVO(VDD)} is the measured zero-current offset voltage for a particular device.

Sensitivity (Sens)

Sensitivity, or Sens, is defined as the ratio of the V_{OUT} swing and the current through the primary conductor, I_p. The current causes a voltage change on V_{OUT} away from V_{QVO} until V_{SAT}. The magnitude and direction of the output voltage is proportional to the magnitude and direction of the current, I_p. The proportional relationship between output voltage and current is Sensitivity, defined as:

$$Sens = \frac{V_{OUT_IP1} - V_{OUT_IP2}}{I_{P1} - I_{P2}} [mV/A]$$

where I_{p1} and I_{p2} are two different currents, and V_{OUT}(I_{p1}) and

V_{OUT}(I_{p2}) are the respective output voltages, at V_{OUT}, at those currents.

Sensitivity Error (E_{SENS})

Sensitivity Error, E_{SENS}, is the deviation of Sensitivity from the nominal sensitivity target value in production testing.

$$E_{SENS} = \frac{SENS_{MEASURED} - SENS_{IDEAL}}{SENS_{IDEAL}} \times 100 [\%]$$

Sensitivity Ratiometry Error (V_{SENS_RAT})

Ideally, a 5% increase in V_{DD} results in a 5% increase in sensitivity. However, the ratiometric response of any sensor is not ideal. Ratiometric sensitivity error, E_{RAT(SENS)}, is specified by the equation:

$$E_{SENS_RAT} = \left[1 - \left(\frac{Sens_{VDD}}{Sens_{VDD(N)}} \times \frac{V_{DD(N)}}{V_{DD}} \right) \right] \times 100 [\%]$$

where V_{DD(N)} is equal to the nominal V_{DD} (3.3 V, or 5 V) and Sens_{VDD(N)} is the measured sensitivity at nominal V_{DD} for a particular device. The symbol V_{DD} is the measured V_{DD} value in application and Sens_{VDD} is the measured sensitivity at that V_{DD} level for a particular device.

Output Saturation Voltage (V_{SAT_H} and V_{SAT_L})

Output Saturation Voltage, V_{SAT}, is defined as the minimum and maximum voltages the V_{OUT} output buffer can drive. V_{SAT_H} is the highest voltage the output can reach, while V_{SAT_L} is the lowest. In other states, the V_{OUT} pin may be pulled outside of V_{SAT_L} and V_{SAT_H}. Note that changing the sensitivity does not change the V_{SAT} points.

Lifetime Drift (E_{SENS_LT} and V_{QVO_LT})

Lifetime drift characteristics are based on the mean drift of the worst-case distribution observed during AEC-Q100 qualification stresses. Solder reflow induces stress and lifetime drift limits apply immediately after solder reflow.

DEFINITIONS OF OVERCURRENT FAULT (OCF) CHARACTERISTICS AND PERFORMANCE

OVERCURRENT FAULT PIN (OCF)

As the output swings, if the sensed current exceeds its set threshold, the overcurrent fault pin triggers with an active low flag. This is internally compared with the VOC voltage.

The implementation for the OCF circuitry is accurate over temperature and does not require further temperature compensation because it is dependent on the Sens and V_{QVO} parameters that are factory-programmed over temperature.

VOLTAGE OVERCURRENT PIN (VOC)

The Voltage Overcurrent pin, or VOC, is a voltage input that is used to set the Overcurrent FAULT Threshold, I_{OC} .

Connecting a resistor divider between V_{DD} and GND sets the voltage at VOC. The voltage on the VOC pin may range from $0.1 \times V_{DD}$ to $0.4 \times V_{DD}$. Overcurrent fault threshold may be set anywhere from 50% to 200% IPR. I_{OC} is set as a percentage of the full-scale sensing range of the device, $I_{PR(MAX)}$, and can be between 50% $I_{PR(MAX)}$ and 200% $I_{PR(MAX)}$. Overcurrent fault threshold versus V_{VOC} is shown in Figure 12.

The equation for calculating the trip current is shown below. For bidirectional devices, the fault trips for both positive and negative currents.

$$I_{OC} = I_{PR(MAX)} \left\{ 5 \times \frac{V_{VOC}}{V_{CC}} \right\}$$

This may be rearranged to solve for the appropriate V_{VOC} value based on a desired overcurrent fault threshold, shown by the equation:

$$V_{VOC} = \frac{V_{CC}}{5} \times \frac{I_{OC}}{I_{PR(MAX)}}$$

By setting V_{VOC} with a resistor divider from V_{DD} , the ratio of V_{VOC}/V_{DD} remains constant with changes to V_{DD} . In this regard, the fault trip point remains constant even as the supply voltage varies.

OVERCURRENT FAULT OUTPUT ERROR (E_{OC})

Overcurrent FAULT Error, E_{OC} , is defined as the difference between the set current threshold and the measured current at which the OCF activates.

OVERCURRENT FAULT HYSTERESIS (I_{OC_HYS})

Overcurrent Hysteresis, or I_{OC_HYS} , is defined as the magnitude of current in percentage of the FS that must drop before a

fault assertion will be cleared. This can be seen as the separation between the voltages [9] to [10] in Figure 13 and Figure 14.

VOC INPUT LINEAR OPERATING RANGE (V_{OR_VOC})

VOC Input Linear Operating Range, V_{OR_VOC} , is the voltage range for V_{VOC} in which the Overcurrent FAULT Threshold, I_{OC} , varies linearly with V_{VOC} .

OVERCURRENT FAULT RESPONSE TIME (t_{OC_RESP})

Overcurrent Response Time, or t_{OC_RESP} , is defined as the time from when the input current reaches the operating point [9] until the OCF pin falls below V_{FAULT_L} [G].

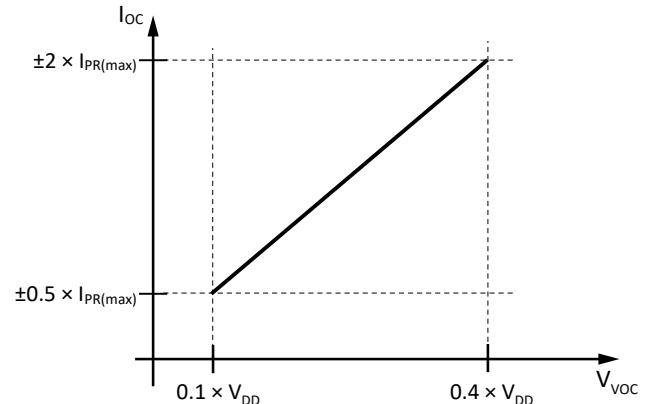

Figure 12: Fault Threshold vs. V_{VOC}

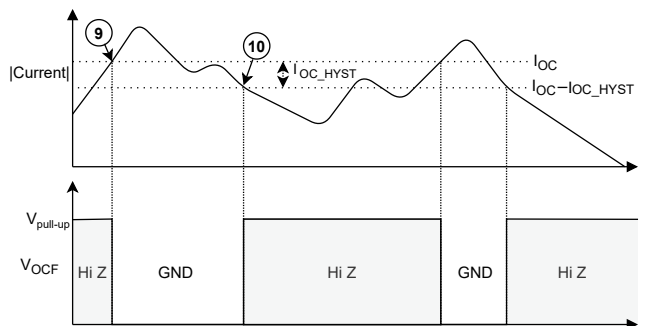

Figure 13: Fault Thresholds and OCF Functionality

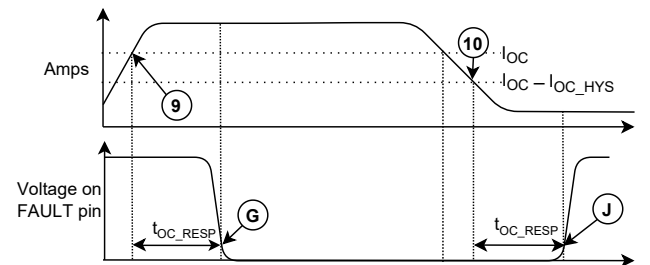

Figure 14: Fault Timing Diagram

THERMAL PERFORMANCE

Resistive heating due to the flow of electrical current in the package should be considered during the thermal design of the application. The sensor, PCB, and PCB terminals generate heat and act as a heat sink.

The thermal response is highly dependent on the PCB layout, copper thickness, cooling method, and the profile of the injected current (including peak current, current on-time, and duty cycle).

In-pad vias help improve thermal performance. Placing vias under the copper pads of the board reduces electrical resistance and improves heat conduction to the PCB (Figure 15 and Figure 16). The ACSEVB-MA16-LA16 includes in-pad vias and is recommended to improve thermal performance.

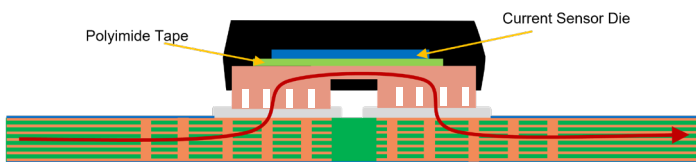

Figure 15: Vias Under Copper Pads (not to scale)



Figure 16: No Vias Under Copper Pads (not to scale)

Figure 17 shows the measured rise in steady-state die temperature of sensor versus DC continuous current at an ambient temperature $T_A = 25^\circ\text{C}$ for two board designs: with filled in-pad vias and without in-pad vias.

Figure 18 shows the measured rise in steady-state die temperature of sensor versus DC continuous current at ambient temperatures of 25°C and 125°C .

The thermal performance of sensor must always be verified in the specific conditions of the application. The maximum junction temperature of the sensor, $T_{J(\text{MAX})} = 165^\circ\text{C}$, must not be exceeded.

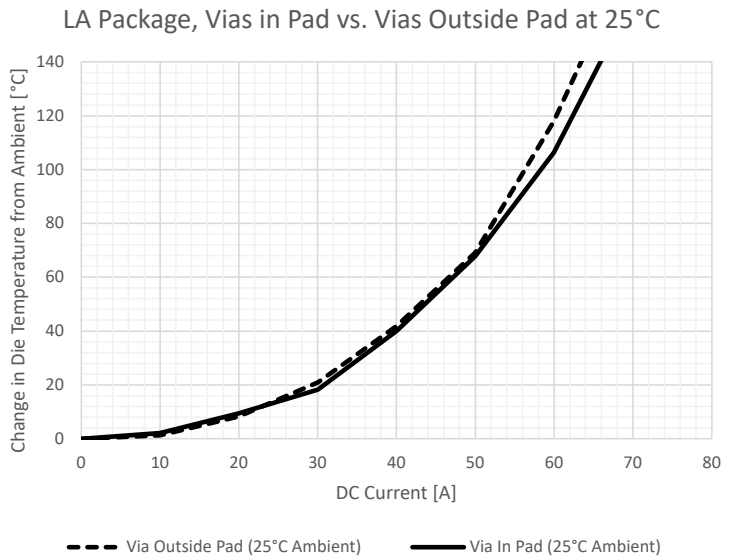

Figure 17: LA Package Performance with/without Vias

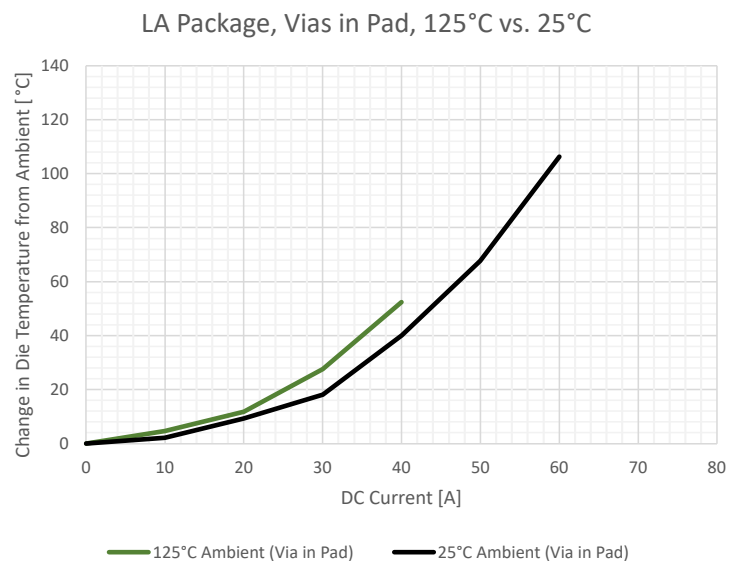
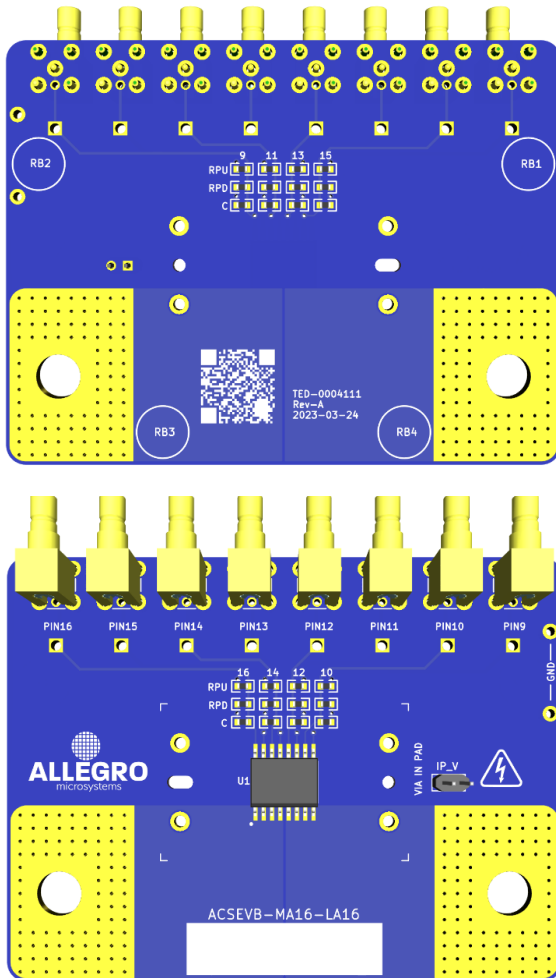

Figure 18: LA Package Performance at 25°C and 125°C

Evaluation Board Layout

Thermal data shown was collected using the ACSEVB-MA16-LA16 Allegro evaluation board (TED-0004111). This board includes six layers of 2 oz. copper weight on all layers. The top and bottom layers of the PCB are shown in Figure 19.



**Figure 19: MA/LA Evaluation Board
Top and Bottom Layers**

PACKAGE OUTLINE DRAWING

For Reference Only – Not for Tooling Use

(Reference Allegro DWG-0000388, Rev. 1 and JEDEC MS-013AA)
 NOT TO SCALE
 Dimensions in millimeters
 Dimensions exclusive of mold flash, gate burrs, and dambar protrusions
 Exact case and lead configuration at supplier discretion within limits shown

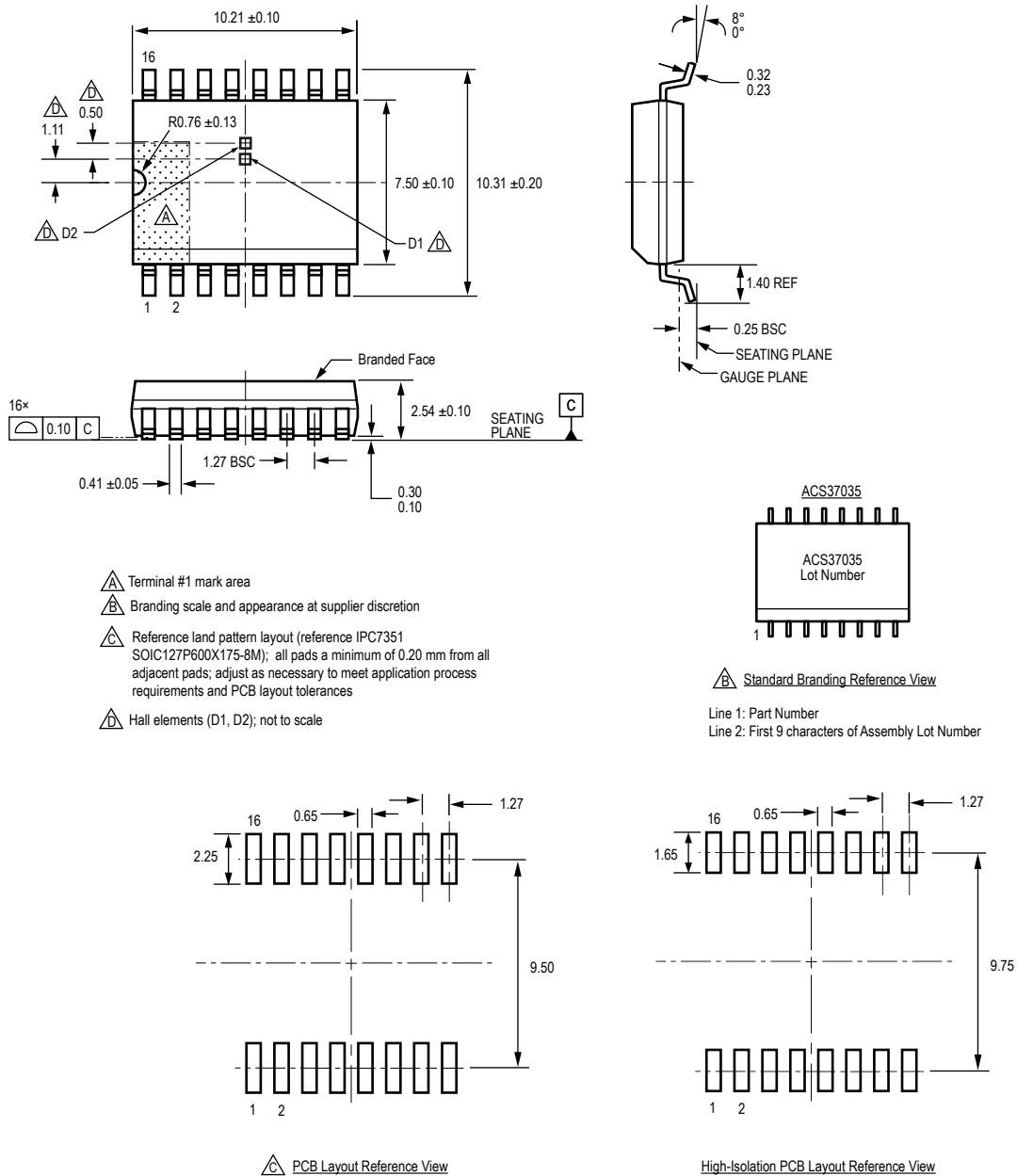

Figure 20: Package LA, 16-PIN SOICW

Revision History

Number	Date	Description
–	March 7, 2025	Initial release
1	March 18, 2025	Updated Sensitivity Drift Over Lifetime value and footnote 1 (pages 8-10); fixed Part Naming Specification diagram (page 2)
2	May 15, 2025	Added ACS37035KLACTR-065B5 variant (page 2, 11); updated performance characteristics tables (page 8, 9, 10); updated application information for a ratiometric device (12-16); minor editorial updates
3	June 9, 2025	Updated Distance Through Insulation value (page 3) and Figures 4 through 7 (pages 12 and 13)
4	February 6, 2026	Added ACS37035KLACTR-020B3 and ACS37035KLACTR-040B3 variants (pages 2, 8, and 9), footnote 2 (page 7), and minor editorial updates.

Copyright 2026, Allegro MicroSystems.

Allegro MicroSystems reserves the right to make, from time to time, such departures from the detail specifications as may be required to permit improvements in the performance, reliability, or manufacturability of its products. Before placing an order, the user is cautioned to verify that the information being relied upon is current.

Allegro's products are not to be used in any devices or systems, including but not limited to life support devices or systems, in which a failure of Allegro's product can reasonably be expected to cause bodily harm.

The information included herein is believed to be accurate and reliable. However, Allegro MicroSystems assumes no responsibility for its use; nor for any infringement of patents or other rights of third parties which may result from its use.

Copies of this document are considered uncontrolled documents.

For the latest version of this document, visit our website:

www.allegromicro.com