

High dV/dt Optimized XtremeSense™ TMR Differential Coreless Current Sensor with Programmable Gain

FEATURES AND BENEFITS

- User-programmable field range:
 - 6 to 8 mT □ 12 to 24 mT
- Preset magnetic field ranges:
 - 0 to 6 mT □ ±6 mT
- Optimized for high dV/dt applications
- Differential sensing for stray magnetic field suppression
- Linear analog output voltage
- 1 MHz bandwidth
- Response time: <300 ns
- Supply voltage: 3.5 to 5.0 V
- Low noise performance
- Package options:
 - 8-lead TSSOP

PACKAGE:



Not to scale

8-lead TSSOP

APPLICATIONS

- Solar/power inverters
- Battery management systems
- Industrial equipment
- Power utility meters
- Power conditioner
- DC/DC converters

DESCRIPTION

The CT456 is a high-bandwidth and low-noise integrated zero-loss contactless current sensor that uses Allegro patented XtremeSense TMR technology to enable high-accuracy current measurements for many consumer, enterprise, and industrial applications. The device supports two standard field ranges where the CT456 senses and translates the magnetic field into a linear analog output voltage. It achieves a total error output of less than $\pm 1.0\%$ over supply voltage and temperature after calibration.

The CT456 is also available in a user-programmable variant, which enables end-of-line calibration of gain and offset. While the sensor is preprogrammed to compensate for gain and offset temperature drift, the ability to adjust offset and gain relaxes mechanical tolerances during sensor mounting.

This coreless current sensor is not only small in size and simple to design, but it also provides effective common-mode rejection of more than -50 dB. This enables the CT456 to have greater than 90% immunity to stray magnetic fields thus having almost no impact on the accuracy of the current measurement.

The device has less than 300 ns output response time while the current consumption is ~ 6.0 mA. The CT456 is equipped with a filter function to reduce the noise on the output pin.

The CT456 is assembled in a low-profile, industry-standard 8-lead TSSOP package that is both green and RoHS compliant.

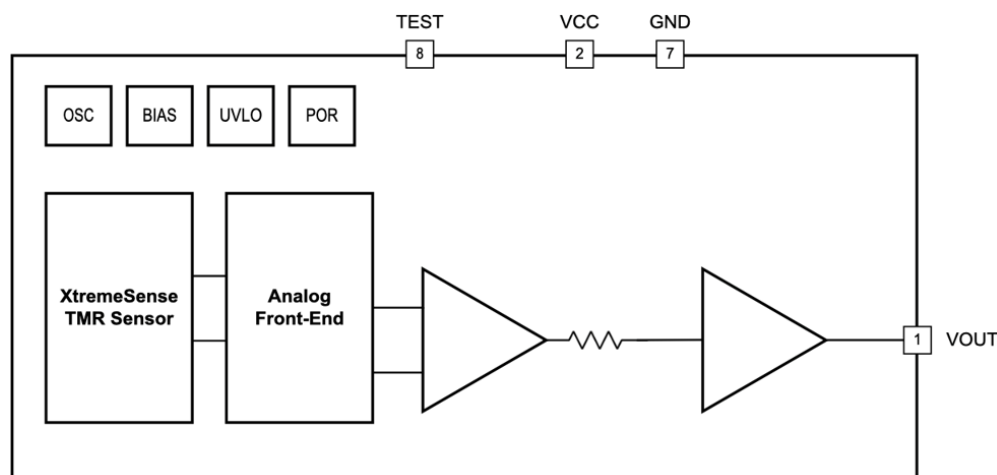

Figure 1: CT456 Functional Block Diagram

Table of Contents

| | | | |
|---------------------------------------|---|--|----|
| Features and Benefits..... | 1 | Pinout Diagram and Terminal List..... | 4 |
| Description..... | 1 | Electrical Characteristics..... | 5 |
| Applications..... | 1 | Functional Description..... | 10 |
| Package..... | 1 | XtremeSense TMR Current Sensor Location..... | 12 |
| Functional Block Diagram..... | 1 | Package Outline Drawing..... | 13 |
| Selection Guide..... | 2 | Tape and Reel Pocket Drawing and Dimensions..... | 14 |
| Evaluation Board Selection Guide..... | 2 | Device Markings..... | 15 |
| Absolute Maximum Ratings..... | 3 | Part Ordering Number Legend..... | 15 |
| Recommended Operating Conditions..... | 3 | Revision History..... | 17 |
| Application Diagram..... | 4 | | |

SELECTION GUIDE

| Part Number | Polarity | Range (mT) | Supply Voltage (V) | Configuration | Operating Temperature Range (°C) | Package |
|---|----------|----------------------------|--------------------|---------------|----------------------------------|---|
| DIFFERENTIAL MAGNETIC FIELD SENSOR | | | | | | |
| CT456-H06B3-TS08 | Bipolar | ±6 | 3.3 | Differential | -40 to 125 | 8-lead TSSOP 3.00 mm × 6.40 mm × 1.10 mm |
| CT456-H06U3-TS08 | Unipolar | 0 to 6 | | | | |
| CT456-H06B5-TS08 | Bipolar | ±6 | 5.0 | | | |
| CT456-H06U5-TS08 | Unipolar | 0 to 6 | | | | |
| PROGRAMMABLE SENSORS | | | | | | |
| CT456-H00B3-TS08 | Bipolar | ±6 to ±8 and ±12 to ±24 | 3.3 | Differential | -40 to 125 | 8-lead TSSOP 3.00 mm × 6.40 mm × 1.10 mm |
| CT456-H00U3-TS08 | Unipolar | | | | | |
| CT456-H00B5-TS08 | Bipolar | ±6 to ±8 and ±12 to ±24 | 5.0 | | | |
| CT456-H00U5-TS08 | Unipolar | | | | | |

EVALUATION BOARD SELECTION GUIDE

| Part Number | Magnetic Field Range (mT) | Supply Voltage (V) | Current Carrying Conductor | Operating Temperature Range (°C) |
|----------------|---------------------------|--------------------|----------------------------|----------------------------------|
| CTD456-BB-06B3 | ±6 | 3.3 | Busbar | -40 to 125 |
| CTD456-BB-06B5 | ±6 | 5.0 | | |
| CTD456-PT-06B3 | ±6 | 3.3 | PCB Trace | |
| CTD456-PT-06B5 | ±6 | 5.0 | | |

ABSOLUTE MAXIMUM RATINGS [1]

| Characteristic | Symbol | Notes | Rating | Unit |
|--|-----------|--|----------------------------|------|
| Supply Voltage Strength | V_{CC} | | -0.3 to 6.0 | V |
| Analog Input/Output Pins Maximum Voltage | $V_{I/O}$ | | -0.3 to $V_{CC} + 0.3$ [2] | V |
| Electrostatic Discharge Protection Level | ESD | Human Body Model (HBM) per JESD22-A114 | ± 2.0 (min) | kV |
| | | Charged Device Model (CDM) per JESD22-C101 | ± 0.5 (min) | kV |
| Junction Temperature | T_J | | -40 to 150 | °C |
| Storage Temperature | T_{STG} | | -65 to 155 | °C |
| Lead Soldering Temperature | T_L | 10 seconds | 260 | °C |

[1] Stresses exceeding the absolute maximum ratings may damage the CT456 and may not function or be operable above the recommended operating conditions and stressing the parts to these levels is not recommended. In addition, extended exposure to stresses above the recommended operating conditions may affect device reliability. The absolute maximum ratings are stress ratings only.

[2] The lower of $V_{CC} + 0.3$ V or 6.0 V.

RECOMMENDED OPERATING CONDITIONS [1]

| Characteristic | Symbol | Notes | Min. | Typ. | Max. | Unit |
|-------------------------------|-----------|----------------------------|------|------|-----------|------|
| Supply Voltage Range | V_{CC} | 5.0 V_{CC} variant (-x5) | 4.75 | 5.00 | 5.50 | V |
| | | 3.3 V_{CC} variant (-x3) | 3.0 | 3.3 | 3.6 | V |
| Output Voltage Range | V_{OUT} | | 0 | - | V_{CC} | V |
| Output Current | I_{OUT} | | - | - | ± 1.0 | mA |
| Operating Ambient Temperature | T_A | Extended Industrial | -40 | 25 | 125 | °C |

[1] The Recommended Operating Conditions table defines the conditions for actual operation of the CT456. Recommended operating conditions are specified to ensure optimal performance to the specifications. Allegro does not recommend exceeding them or designing to absolute maximum ratings.

APPLICATION DIAGRAM

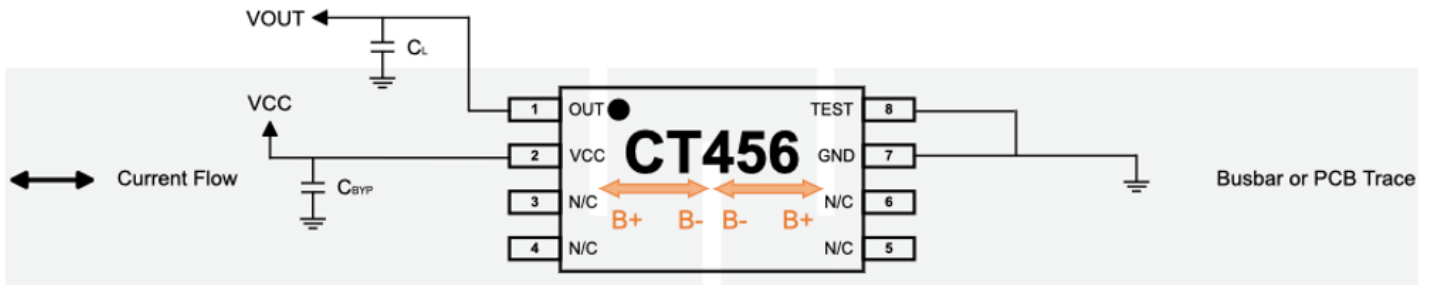

Figure 3: CT456 Application Diagram for Measuring Differential Magnetic Field

Table 1: Recommended External Components

| Component | Description | Vendor and Part Number | Min. | Typ. | Max. | Unit |
|-----------|----------------------------|--------------------------|------|------|------|---------|
| C_{BYP} | 1.0 μ F, X5R or better | Murata GRM155C81A105KA12 | – | 1.0 | – | μ F |

PINOUT DIAGRAM AND TERMINAL LIST

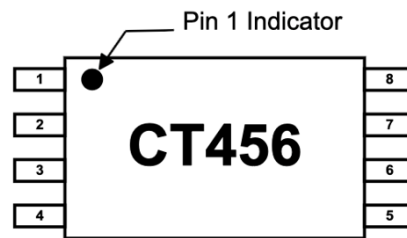

Figure 2: CT456 Pinout Diagram for 8-lead TSSOP Package (Top-Down View)

Terminal List

| Number | Name | Function |
|------------|------|---|
| 1 | OUT | Analog output voltage that represents the measured current/field. |
| 2 | VCC | Supply voltage. |
| 3, 4, 5, 6 | NC | No connect (do not use). |
| 7 | GND | Ground. |
| 8 | TEST | Pin used for factory calibration. Connect to Ground. |

ELECTRICAL CHARACTERISTICS: $V_{CC} = 3.0$ to 3.6 V or 4.75 to 5.50 V, $T_A = -40^\circ\text{C}$ to 125°C , $C_{BYP} = 1.0$ μF , unless otherwise specified; typical values are $V_{CC} = 3.3$ or 5.00 V and $T_A = 25^\circ\text{C}$

| Characteristics | Symbol | Test Conditions | Min. | Typ. | Max. | Unit | |
|--|------------------|---|--------------------------------|-----------------|-------|---------------|---|
| POWER SUPPLIES | | | | | | | |
| Supply Current | I_{CC} | $f_{BW} = 1$ MHz, no load, $B_{OP} = 0$ mT | – | 6.0 | 9.0 | mA | |
| OUT Maximum Drive Capability | I_{OUT} | OUT covers 10% to 90% of V_{CC} span | –1.0 | – | +1.0 | mA | |
| OUT Capacitive Load | C_{L_OUT} | | – | – | 100 | pF | |
| OUT Resistive Load | R_{L_OUT} | | – | 100 | – | k Ω | |
| Power Supply Rejection Ratio [1] | PSRR | | – | 35 | – | dB | |
| Sensitivity Power Supply Rejection Ratio [1] | SPSRR | | – | 35 | – | dB | |
| Offset Power Supply Rejection Ratio [1] | OPSRR | | – | 40 | – | dB | |
| Bandwidth [1] | f_{BW} | Small Signal = –3 dB | – | 1.0 | – | MHz | |
| ANALOG OUTPUT (OUT) | | | | | | | |
| OUT Voltage Linear Range | V_{OUT} | 5.0 V_{CC} variant (-x5) | 0.50 | – | 4.50 | V | |
| | | 3.3 V_{CC} variant (-x3) | 0.65 | – | 2.65 | V | |
| Output High Saturation Voltage | V_{OUT_SAT} | $T_A = 25^\circ\text{C}$ | $V_{CC} - 0.30$ | $V_{CC} - 0.25$ | – | V | |
| Voltage Output Quiescent | V_{OQ} | $T_A = 25^\circ\text{C}$, $B_{OP} = 0$ mT | 5.0 V_{CC} , bipolar (-xB5) | 2.490 | 2.500 | 2.510 | V |
| | | | 5.0 V_{CC} , unipolar (-xU5) | 0.495 | 0.500 | 0.505 | V |
| | | | 3.3 V_{CC} , bipolar (-xB3) | 1.645 | 1.650 | 1.655 | V |
| | | | 3.3 V_{CC} , unipolar (-xU3) | 0.645 | 0.650 | 0.655 | V |
| TIMINGS | | | | | | | |
| Power-On Time | t_{ON} | $V_{CC} \geq 4.0$ V variant (-x5), $V_{CC} \geq 2.5$ V variant (-x3) | – | 100 | 200 | μs | |
| Rise Time [1] | t_{RISE} | $B_{OP} = B_{RNG(MAX)}$, $T_A = 25^\circ\text{C}$, $C_L = 100$ pF | – | 200 | – | ns | |
| Response Time [1] | $t_{RESPONSE}$ | $B_{OP} = B_{RNG(MAX)}$, $T_A = 25^\circ\text{C}$, $C_L = 100$ pF | – | 300 | – | ns | |
| Propagation Delay [1] | t_{DELAY} | $B_{OP} = B_{RNG(MAX)}$, $T_A = 25^\circ\text{C}$, $C_L = 100$ pF | – | 250 | – | ns | |
| PROTECTION | | | | | | | |
| Undervoltage Lockout | V_{UVLO} | Rising V_{CC} | – | 2.50 | – | V | |
| | | Falling V_{CC} | – | 2.45 | – | V | |
| UVLO Hysteresis | V_{UV_HYS} | | – | 50 | – | mV | |
| LIFETIME DRIFT | | | | | | | |
| Total Output Error Lifetime Drift [1] | E_{TOT_DRIFT} | | – | 1 | – | % FS | |

[1] Guaranteed by design and characterization; not tested in production.

ELECTRICAL CHARACTERISTICS

$V_{CC} = 3.3$ or 5.0 V, $T_A = 25^\circ\text{C}$, and $C_{BYP} = 1.0 \mu\text{F}$ (unless otherwise specified)

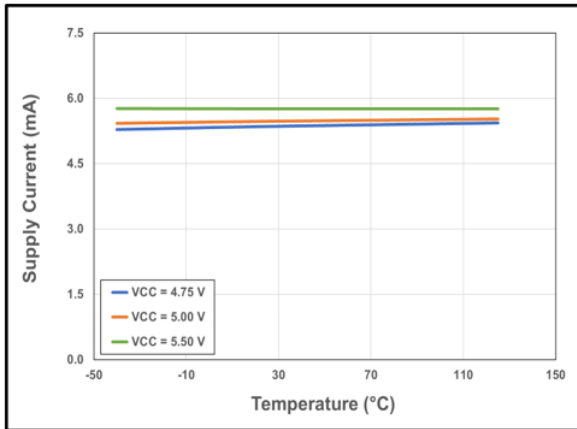

Figure 4: 5.0 V_{CC} variant (-x5) Supply Current vs. Temperature vs. Supply Voltage

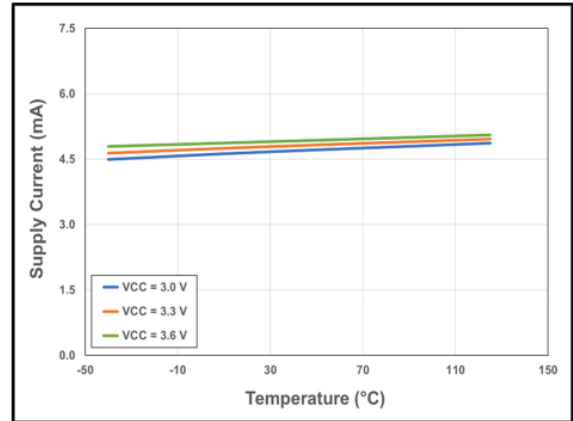

Figure 5: 3.3 V_{CC} variant (-x3) Supply Current vs. Temperature vs. Supply Voltage

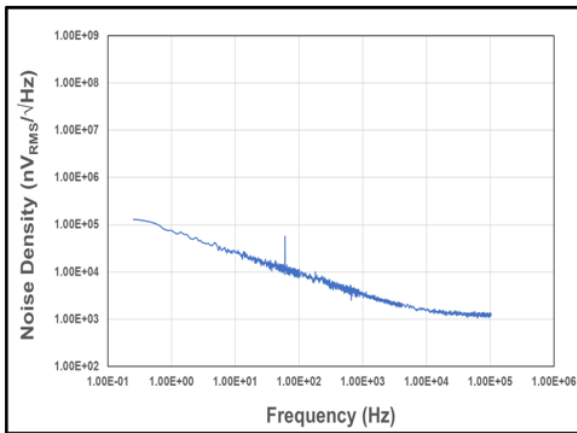

Figure 6: Noise Density vs. Frequency

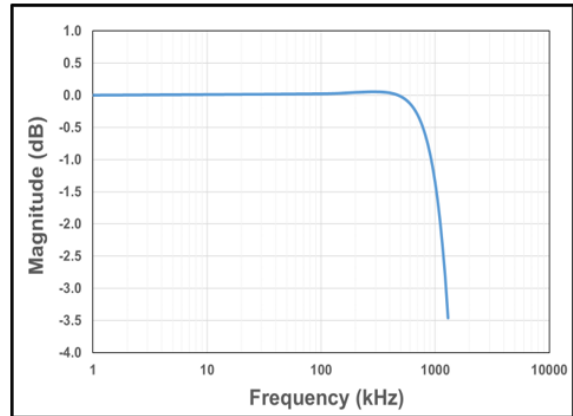

Figure 7: CT456 Bandwidth

CT456-x06Ux: 0 to 6 mT – ELECTRICAL CHARACTERISTICS: $V_{CC} = 3.0$ to 3.6 V or 4.75 to 5.50 V, $T_A = -40^\circ\text{C}$ to 125°C , $C_{BYP} = 1.0$ μF , unless otherwise specified; typical values are $V_{CC} = 3.3$ or 5.00 V and $T_A = 25^\circ\text{C}$

| Characteristics | Symbol | Test Conditions | Min. | Typ. | Max. | Unit |
|---------------------------------|--------------|---|------|-----------|------|---------------------|
| Magnetic Field Range | B_{RNG} | | 0 | – | 6 | mT |
| Sensitivity | S | 5.0 V_{CC} variant (-x5) | – | 666.7 | – | mV/mT |
| | | 3.3 V_{CC} variant (-x3) | – | 333.3 | – | mV/mT |
| Noise [1] | e_N | $T_A = 25^\circ\text{C}$, $f_{BW} = 100$ kHz | – | 2.45 | – | μT_{RMS} |
| OUT ACCURACY PERFORMANCE | | | | | | |
| Non-Linearity Error | E_{LIN} | | – | ± 0.2 | – | % FS |
| Sensitivity Error | E_{SENS} | | – | ± 0.3 | – | % FS |
| Offset Voltage | V_{OFFSET} | $B_{OP} = 0$ mT | – | ± 0.3 | – | % FS |

[1] Guaranteed by design and characterization; not tested in production.

CT456-x06Bx: ± 6 mT – ELECTRICAL CHARACTERISTICS: $V_{CC} = 3.0$ to 3.6 V or 4.75 to 5.50 V, $T_A = -40^\circ\text{C}$ to 125°C , $C_{BYP} = 1.0$ μF , unless otherwise specified; typical values are $V_{CC} = 3.3$ or 5.00 V and $T_A = 25^\circ\text{C}$

| Characteristics | Symbol | Test Conditions | Min. | Typ. | Max. | Unit |
|---------------------------------|--------------|---|------|-----------|------|---------------------|
| Magnetic Field Range | B_{RNG} | | -6 | – | 6 | mT |
| Sensitivity | S | 5.0 V_{CC} variant (-x5) | – | 333.3 | – | mV/mT |
| | | 3.3 V_{CC} variant (-x3) | – | 166.7 | – | mV/mT |
| Noise [1] | e_N | $T_A = 25^\circ\text{C}$, $f_{BW} = 100$ kHz | – | 2.77 | – | μT_{RMS} |
| OUT ACCURACY PERFORMANCE | | | | | | |
| Non-Linearity Error | E_{LIN} | | – | ± 0.1 | – | % FS |
| Sensitivity Error | E_{SENS} | | – | ± 0.3 | – | % FS |
| Offset Voltage | V_{OFFSET} | $B_{OP} = 0$ mT | – | ± 0.3 | – | % FS |

[1] Guaranteed by design and characterization; not tested in production.

CT456-x00Ux: Programmable Gain – ELECTRICAL CHARACTERISTICS: $V_{CC} = 3.0$ to 3.6 V or 4.75 to 5.50 V, $T_A = -40^\circ\text{C}$ to 125°C , $C_{BYP} = 1.0$ μF , unless otherwise specified; typical values are $V_{CC} = 3.3$ or 5.00 V and $T_A = 25^\circ\text{C}$

| Characteristics | Symbol | Test Conditions | Min. | Typ. | Max. | Unit |
|-----------------------------------|---------------|----------------------------|------|-----------|------|-------|
| Programmable Magnetic Field Range | B_{RNG} | | 6 | – | 8 | mT |
| | | | 12 | – | 24 | mT |
| Maximum Programmable Sensitivity | $S_{P_{MAX}}$ | 5.0 V_{CC} variant (-x5) | – | 666.7 | – | mV/mT |
| | | 3.3 V_{CC} variant (-x3) | – | 333.3 | – | mV/mT |
| Minimum Programmable Sensitivity | $S_{P_{MIN}}$ | 5.0 V_{CC} variant (-x5) | – | 166.7 | – | mV/mT |
| | | 3.3 V_{CC} variant (-x3) | – | 83.4 | – | mV/mT |
| OUT ACCURACY PERFORMANCE | | | | | | |
| Non-Linearity Error | E_{LIN} | | – | ± 0.3 | – | % FS |
| Sensitivity Error | E_{SENS} | | – | ± 0.3 | – | % FS |
| Offset Voltage | V_{OFFSET} | $B_{OP} = 0$ mT | – | ± 0.3 | – | % FS |

[1] Guaranteed by design and characterization; not tested in production.

CT456-x00Bx: Programmable Gain – ELECTRICAL CHARACTERISTICS: $V_{CC} = 3.0$ to 3.6 V or 4.75 to 5.50 V, $T_A = -40^\circ\text{C}$ to 125°C , $C_{BYP} = 1.0$ μF , unless otherwise specified; typical values are $V_{CC} = 3.3$ or 5.00 V and $T_A = 25^\circ\text{C}$

| Characteristics | Symbol | Test Conditions | Min. | Typ. | Max. | Unit |
|-----------------------------------|---------------|----------------------------|----------|-----------|----------|-------|
| Programmable Magnetic Field Range | B_{RNG} | | ± 6 | – | ± 8 | mT |
| | | | ± 12 | – | ± 24 | mT |
| Maximum Programmable Sensitivity | $S_{P_{MAX}}$ | 5.0 V_{CC} variant (-x5) | – | 333.3 | – | mV/mT |
| | | 3.3 V_{CC} variant (-x3) | – | 166.7 | – | mV/mT |
| Minimum Programmable Sensitivity | $S_{P_{MIN}}$ | 5.0 V_{CC} variant (-x5) | – | 83.4 | – | mV/mT |
| | | 3.3 V_{CC} variant (-x3) | – | 41.7 | – | mV/mT |
| OUT ACCURACY PERFORMANCE | | | | | | |
| Non-Linearity Error [1] | E_{LIN} | | – | ± 0.2 | – | % FS |
| Sensitivity Error [1] | E_{SENS} | | – | ± 0.3 | – | % FS |
| Offset Voltage [1] | V_{OFFSET} | $B_{OP} = 0$ mT | – | ± 0.3 | – | % FS |

[1] Guaranteed by design and characterization; not tested in production.

Calibration Description

The CT456-x00MR is factory-trimmed for sensitivity and offset temperature drift. The sensor provides the ability to adjust gain to allow for all the mechanical tolerances during manufacturing. Gain calibration is recommended to be performed at room temperature (25°C) using the Allegro CTC4000 Calibration Box.

ELECTRICAL CHARACTERISTICS

V_{CC} = 3.3 or 5.0 V and C_{BYP} = 1.0 μF

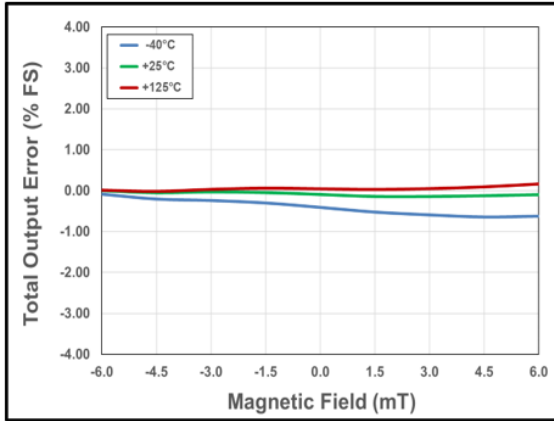

Figure 8: CT456-x06B5x Total Output Error vs. B Field

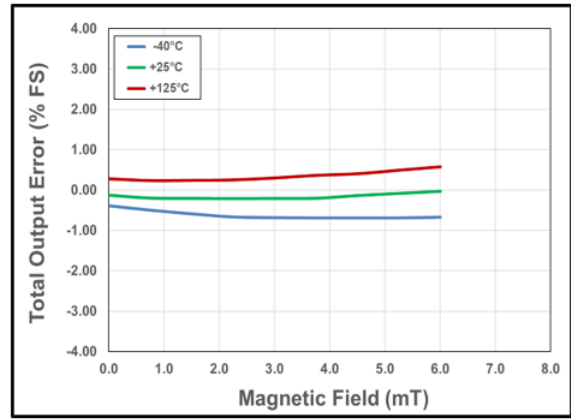

Figure 9: CT456-x06U5x Total Output Error vs. B Field

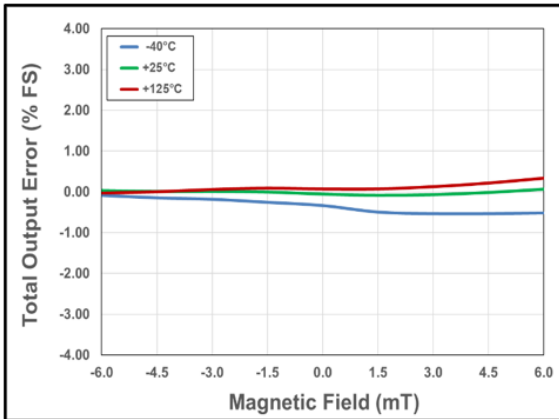

Figure 10: CT456-x06B3x Total Output Error vs. B Field

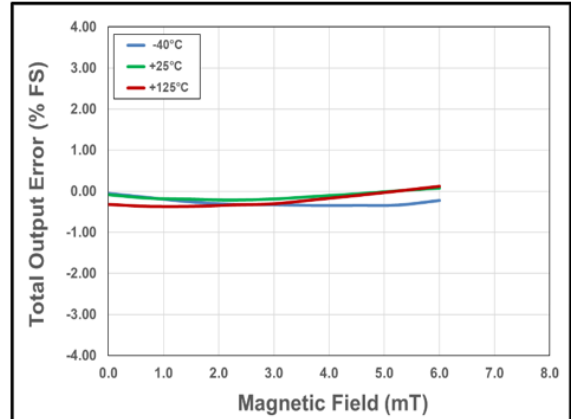

Figure 11: CT456-x06U3x Total Output Error vs. B Field

FUNCTIONAL DESCRIPTION

Overview

The CT456 is a very high accuracy coreless and contactless current sensor that can sense magnetic fields from 6 to 24 mT. The device has high sensitivity and a wide dynamic range with excellent accuracy (low total output error) across temperature. This current sensor supports two field ranges as standard:

- 0 to 6 mT
- ±6 mT

The CT456 is also available in a user-programmable variant which enables end-of-line calibration of gain. While the sensor is pre-programmed to adjust sensitivity and offset temperature drift, the ability to adjust gain relaxes mechanical tolerances during sensor mounting.

When current is flowing through a busbar above or below the CT456, the XtremeSense TMR sensor inside the chip senses the field which in turn generates a differential voltage signals that then goes through the Analog Front-End (AFE) to output a current measurement as low as ±1.0% full-scale total output error (E_{OUT}).

The chip is designed to enable a fast response time of 300 ns for the current measurement from the OUT pin as the bandwidth for the CT456 is 1.0 MHz. Even with a high bandwidth, the chip consumes a minimal amount of power.

Linear Output Current Measurement

The CT456 provides a continuous linear analog output voltage which represents the magnetic field generated by the current flowing through the busbar. The output voltage range of OUT is from 0.50 to 4.50 V with a V_{OQ} of 0.50 and 2.50 V for unidirectional and bidirectional fields, respectively. Figure 12 illustrates the output voltage range of the OUT pin as a function of the measured field.

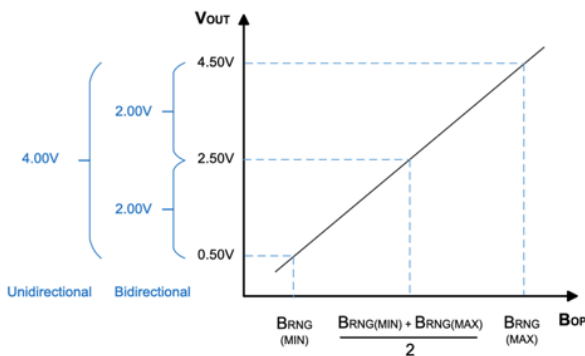

Figure 12: Linear Output Voltage Range (OUT) vs. Measured Magnetic Field (B_{OP})

Power-On Time (t_{ON})

Power-On Time (t_{ON}) of 100 μs is the amount of time required by CT456 to start up, fully power the chip, and becoming fully operational from the moment the supply voltage is greater than the UVLO voltage. This time includes the ramp-up time and the settling time (within 10% of steady-state voltage under an applied magnetic field) after the power supply has reached the minimum V_{CC} .

Response Time ($t_{RESPONSE}$)

Response Time ($t_{RESPONSE}$) of 300 ns for the CT456 is the time interval between the following terms:

1. When the primary current signal reaches 90% of its final value,
2. When the chip reaches 90% of its output corresponding to the applied current.

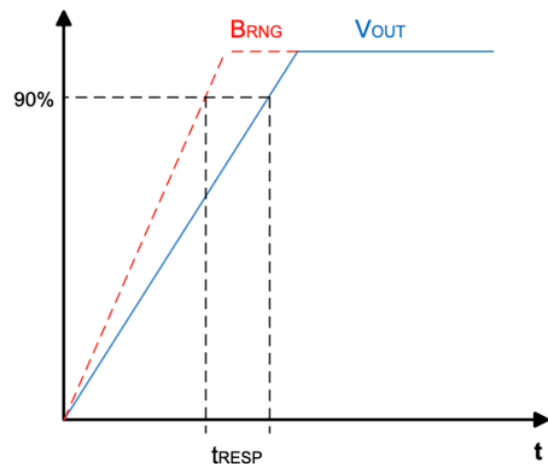

Figure 13: CT456 Response Time Curve

Rise Time (t_{RISE})

Rise Time (t_{RISE}) is the time interval of when it reaches 10% and 90% of the full-scale output voltage. The t_{RISE} of the CT456 is 200 ns.

Propagation Delay (t_{DELAY})

Propagation Delay (t_{DELAY}) is the time difference between these two events:

1. When the primary current reaches 20% of its final value
2. When the chip reaches 20% of its output corresponding to the applied current.

The CT456 has a propagation delay of 250 ns.

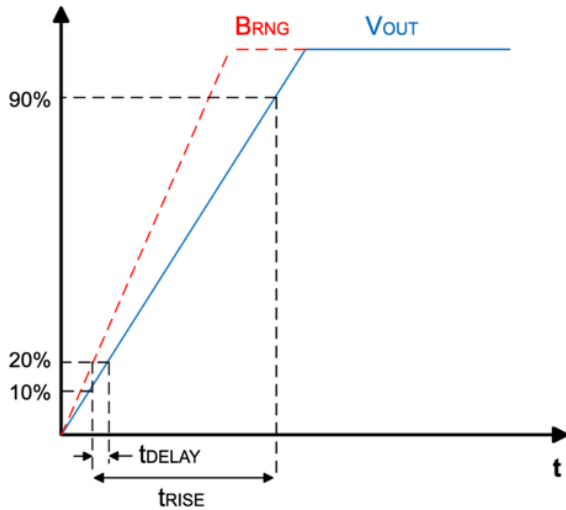

Figure 14: CT456 Propagation Delay and Rise Time Curve

Undervoltage Lockout (UVLO)

The Undervoltage Lockout protection circuitry of the CT456 is activated when the supply voltage (V_{CC}) falls below 2.45 V. The CT456 remains in a low quiescent state until V_{CC} rises above the UVLO threshold (2.50 V). In the condition where the V_{CC} is less than 2.45 V and UVLO is triggered, the output from the CT456 is not valid. Once V_{CC} rises above 2.5 V, then the UVLO is cleared.

Current Sensing

The CT456 can sense and therefore measure the current by either placing a current-carrying busbar above or under the device. The chip is also sensitive enough to measure the current from a PCB trace that is routed beneath it.

Bypass Capacitor

A single 1.0 μF capacitor is needed for the VCC pin to reduce the noise from the power supply and other circuits. This capacitor should be placed as close as possible to the CT456 to minimize inductance and resistance between the two devices.

XtremeSense TMR Current Sensor Location

The XtremeSense TMR current sensor location of the CT456 is shown below. All dimensions in the figures are nominal.

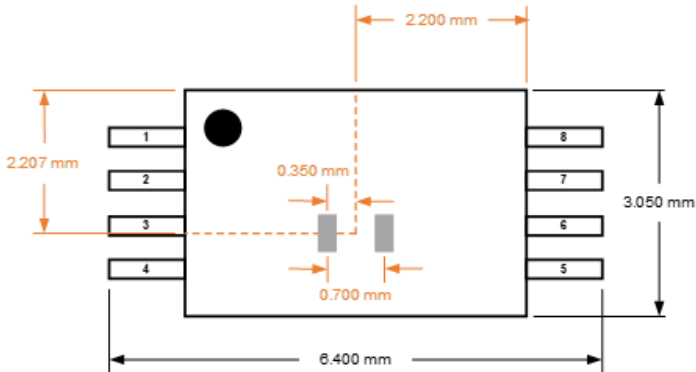

Figure 15: XtremeSense TMR Current Sensor Location in x-y Plane for CT456 in TSSOP-8 Package

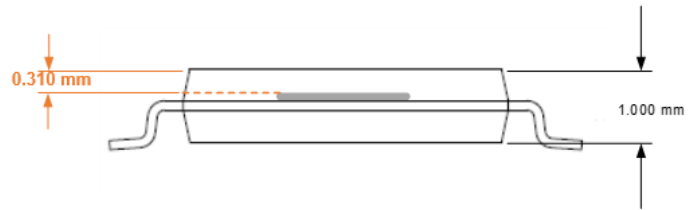

Figure 16: XtremeSense TMR Current Sensor Location in z Dimension for CT456 in TSSOP-8 Package

PACKAGE OUTLINE DRAWING

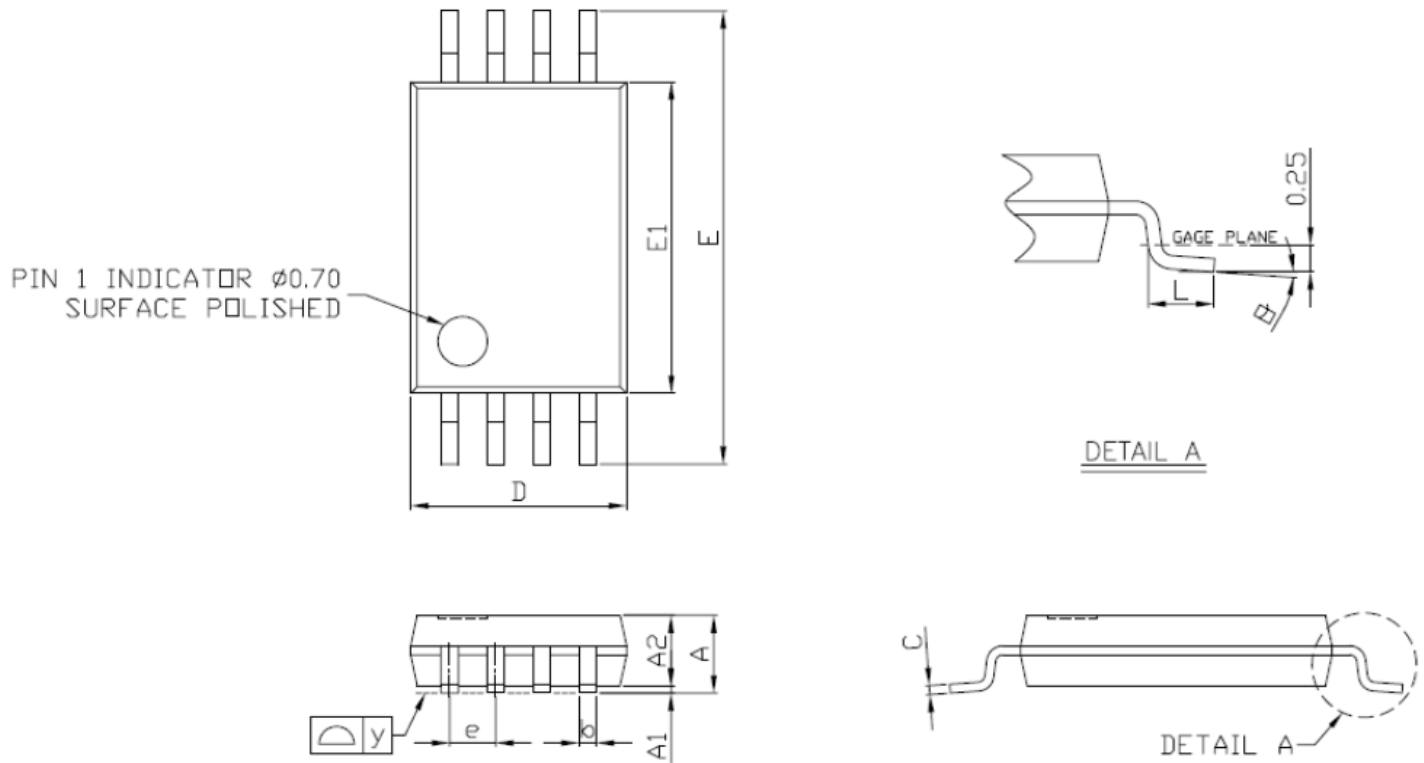
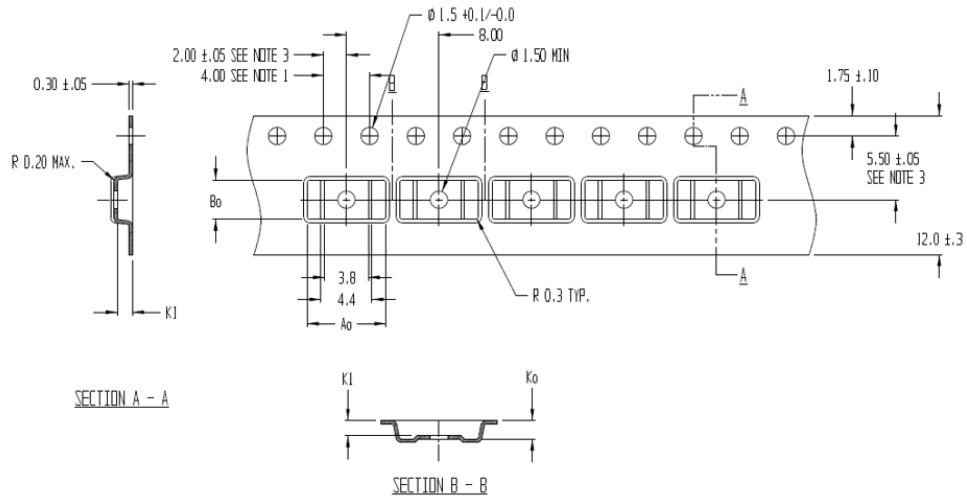

Figure 17: TSSOP-8 Package Drawing and Dimensions

Table 2: CT456 TSSOP-8 Package Dimensions

| Symbol | Dimensions in Millimeters (mm) | | |
|----------|--------------------------------|-------|-------|
| | Min. | Typ. | Max. |
| A | 1.05 | 1.10 | 1.20 |
| A1 | 0.05 | 0.10 | 0.15 |
| A2 | – | 1.00 | 1.05 |
| b | 0.25 | – | 0.30 |
| C | – | 0.127 | – |
| D | 2.90 | 3.05 | 3.10 |
| E | 6.20 | 6.40 | 6.60 |
| E1 | 4.30 | 4.40 | 4.50 |
| e | – | 0.65 | – |
| L | 0.50 | 0.60 | 0.70 |
| y | – | – | 0.076 |
| θ | 0° | 4° | 8° |

TAPE AND REEL POCKET DRAWINGS AND DIMENSIONS



- NOTES:
1. TO SPROCKET HOLE PITCH CUMULATIVE TOLERANCE ±0.2
 2. CAMBER IN COMPLIANCE WITH EIA-481
 3. POCKET POSITION RELATIVE TO SPROCKET HOLE MEASURED AS TRUE POSITION OF POCKET, NOT POCKET HOLE

Ao = 6.60
 Bo = 3.40
 Ko = 1.60
 K1 = 1.30

Figure 18: Tape and Pocket Drawing for TSSOP-8 Package

DEVICE MARKINGS

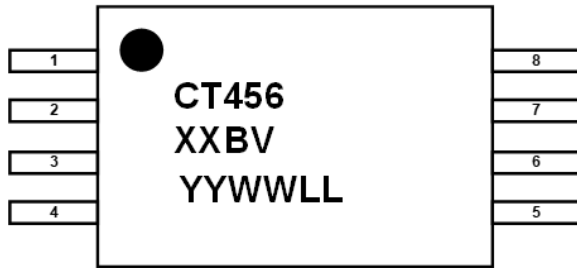
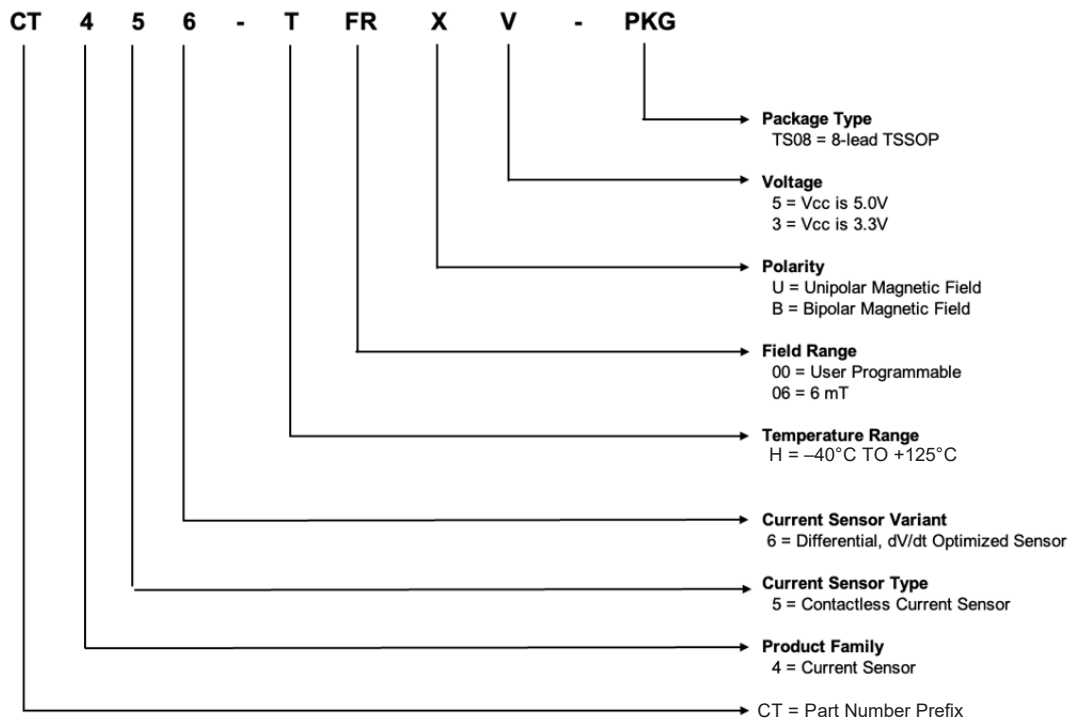

Figure 19: CT456 Device Marking for 8-Lead TSSOP Package

Table 3: CT456 Device Marking Definition for 8-lead TSSOP Package

| Row No. | Code | Definition |
|---------|-------|-------------------------------|
| 1 | • | Pin 1 Indicator |
| 2 | CT456 | Allegro Part Number |
| 3 | XX | Maximum Magnetic Field Rating |
| 3 | B | Sensing Polarity |
| 3 | V | Supply Voltage |
| 4 | YY | Calendar Year |
| 4 | WW | Work Week |
| 4 | LL | Lot Code |

PART ORDERING NUMBER LEGEND



Revision History

| Number | Date | Description |
|--------|-------------------|--|
| 2 | November 2, 2023 | Document rebranded and minor editorial updates |
| 3 | February 29, 2024 | Removed AEC-Q100 (pages 1, 2, 15); updated Offset Voltage (page 8); removed Out Accuracy Performance footnotes (pages 7-8); updated Sensitivity and removed Noise (page 8) |

Copyright 2024, Allegro MicroSystems.

Allegro MicroSystems reserves the right to make, from time to time, such departures from the detail specifications as may be required to permit improvements in the performance, reliability, or manufacturability of its products. Before placing an order, the user is cautioned to verify that the information being relied upon is current.

Allegro's products are not to be used in any devices or systems, including but not limited to life support devices or systems, in which a failure of Allegro's product can reasonably be expected to cause bodily harm.

The information included herein is believed to be accurate and reliable. However, Allegro MicroSystems assumes no responsibility for its use; nor for any infringement of patents or other rights of third parties which may result from its use.

Copies of this document are considered uncontrolled documents.

For the latest version of this document, visit our website:

www.allegromicro.com