

High Precision Programmable Linear Hall Effect Sensor IC with EEPROM, Analog Output, and Advanced Output Linearization

Last-Time Buy

These parts are in production but have been determined to be LAST TIME BUY. This classification indicates that the product is obsolete and notice has been given. Sale of this device is currently restricted to existing customer applications. The device should not be purchased for new design applications because of obsolescence in the near future. Samples are no longer available.

Date of status change: December 5, 2018

Deadline for receipt of LAST TIME BUY orders: December 27, 2019

Recommended Substitutions:

For existing customer transition, and for new customers or new applications, contact Allegro Sales.

NOTE: For detailed information on purchasing options, contact your local Allegro field applications engineer or sales representative.

Allegro MicroSystems reserves the right to make, from time to time, revisions to the anticipated product life cycle plan for a product to accommodate changes in production capabilities, alternative product availabilities, or market demand. The information included herein is believed to be accurate and reliable. However, Allegro MicroSystems assumes no responsibility for its use; nor for any infringements of patents or other rights of third parties which may result from its use.

High Precision Programmable Linear Hall Effect Sensor IC with EEPROM, Analog Output, and Advanced Output Linearization

FEATURES AND BENEFITS

- Advanced 32-segment output linearization functionality enables high output accuracy and linearity in the presence of non-linear input magnetic fields
- Customer adjustable sensitivity and offset, bandwidth, output clamps, and 1st and 2nd order temperature compensation
- Simultaneous programming of all parameters for accurate and efficient system optimization
- Factory trimmed magnetic input range (coarse sensitivity) and signal offset
- Sensitivity temperature coefficient and magnetic offset drift preset at Allegro, for maximum device accuracy without requiring customer temperature testing
- Temperature-stable, mechanical stress immune, and extremely low noise device output via proprietary four-phase chopper stabilization and differential circuit design techniques
- Diagnostics for open circuit and undervoltage
- Wide ambient temperature range: -40°C to 150°C
- Operates with 4.5 to 5.5 V supply voltage

PACKAGE: 4-pin SIP (suffix KT)

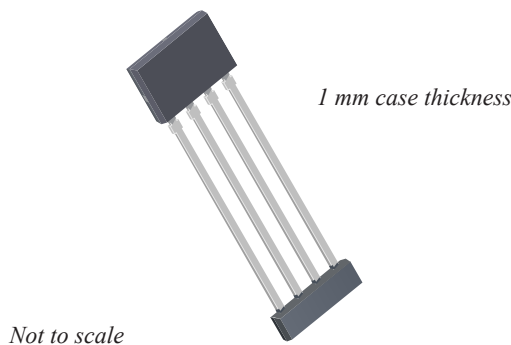

DESCRIPTION

The A1340 device is a high precision, programmable Hall effect linear sensor integrated circuit (IC) for both automotive and non-automotive applications. The signal path of the A1340 provides flexibility through external programming that allows the generation of an accurate, and customized output voltage from an input magnetic signal. The A1340 provides 12 bits of output resolution, and supports a maximum bandwidth of 3 kHz.

The BiCMOS, monolithic integrated circuit incorporates a Hall sensor element, precision temperature-compensating circuitry to reduce the intrinsic sensitivity and offset drift of the Hall element, a small-signal high-gain amplifier, proprietary dynamic offset cancellation circuits, and advanced output linearization circuitry.

With on-board EEPROM and advanced signal processing functions, the A1340 provides an unmatched level of customer reprogrammable options for characteristics such as gain and offset, bandwidth, and output clamps. Multiple input magnetic range and signal offset choices can be preset at the factory. In addition, the device supports separate hot and cold, 1st and 2nd order temperature compensation.

A key feature of the A1340 is its ability to produce a highly linear device output for nonlinear input magnetic fields. To achieve this, the device divides the output into 32 equal segments and applies a unique linearization coefficient factor to each segment. Linearization coefficients are stored in a look-up table in EEPROM.

The A1340 sensor is available in a lead (Pb) free 4-pin single in-line package (KT suffix), with 100% matte tin leadframe plating.

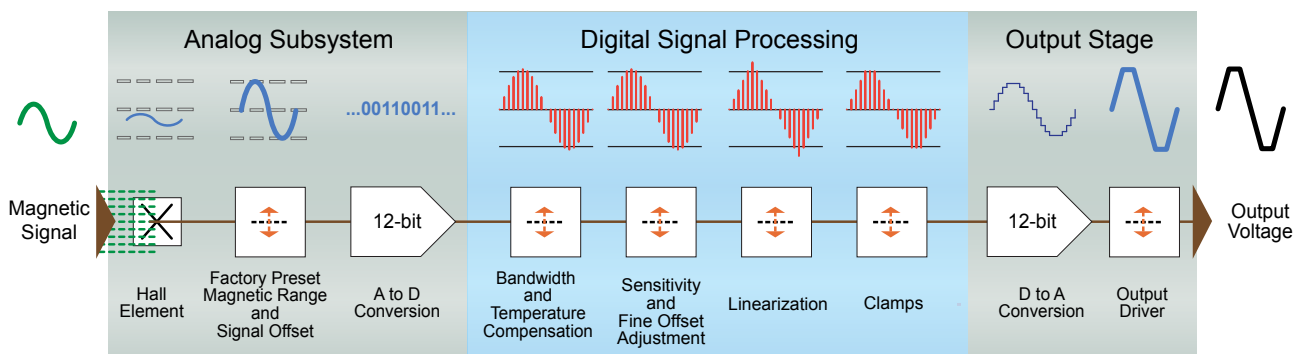

Figure 1: A1340 Signal Processing Path.

Functions with programmable parameters indicated by double-headed arrows.

SELECTION GUIDE

Part Number	Packing*
A1340LKTTN-4-T	4000 pieces per 13-in. reel



*Contact Allegro™ for additional packing options

Table of Contents

Specifications	3	Writing to Volatile Registers	20
Absolute Maximum Ratings	3	Reading from EEPROM	20
Thermal Characteristics	3	Error Checking	20
Functional Block Diagram	4	Serial Interface Reference	21
Pin-out Diagram and Terminal List	4	Serial Interface Message Structure	22
Electrical Characteristics	5	Read	23
Magnetic Characteristics	6	Read Acknowledge	24
Programmable Characteristics	7	Write	24
Thermal Characteristics	10	Write Access Code	25
Characteristic Performance	11	Write Disable Code	25
Functional Description	14	Write Enable Code	26
Signal Processing Parameter Setting	14	EEPROM Structure	27
Digital Signal Processing	14	EEPROM Customer-Programmable Parameter	
Bandwidth Selection	14	Reference	29
Temperature Compensation	14	Definitions of Terms	37
Digital Output Sensitivity (Gain) Adjustment	16	Power-On Time, t_{PO}	37
Output Fine Offset Adjustment	16	Response Time, t_{RESP}	37
Linearization of Output	16	Quiescent Voltage Output (QVO), $V_{OUT(Q)}$	37
Output Polarity	17	Sensitivity, Sens	37
Output Signal Clamps Setting	18	Magnetic Offset Drift Through Temperature Range	37
Protection Features	18	Sensitivity Drift Through Temperature Range	38
Typical Application	18	Sensitivity Drift Due to Package Hysteresis,	
Programming Serial Interface	19	$\Delta Sens_{PKG}$	38
Transaction Types	19	Linearity Sensitivity Error	38
Writing the Access Code	19	Ratiometric	38
Writing to Non-Volatile EEPROM	19	Package Outline Drawing	40

SPECIFICATIONS

ABSOLUTE MAXIMUM RATINGS

Characteristic	Symbol	Notes	Rating	Unit
Forward Supply Voltage	V_{CC}		19	V
Reverse Supply Voltage	V_{RCC}		-20	V
Forward Supply Current	I_{CC}		30	mA
Reverse Supply Current	I_{RCC}		-30	mA
Forward Output Voltage (VOUT Pin)	V_{OUT}	Maximum voltage depends on programmed voltage settings	29	V
Reverse Output Voltage (VOUT Pin)	V_{ROUT}		-0.5	V
Forward Output Sink Current (VOUT Pin)	I_{SINK}		50	mA
Maximum Number of EEPROM Write Cycles	EEPROM _W (max)		100	cycle
Operating Ambient Temperature	T_A	L temperature range	-40 to 150	°C
Maximum Junction Temperature	$T_J(max)$		165	°C
Storage Temperature	T_{stg}		-65 to 165	°C

THERMAL CHARACTERISTICS: May require derating at maximum conditions, see application information

Characteristic	Symbol	Test Conditions*	Value	Unit
Package Thermal Resistance	$R_{\theta JA}$	1-layer PCB with copper limited to solder pads	174	°C/W

*Additional thermal information available on the Allegro website.

Power Dissipation versus Ambient Temperature

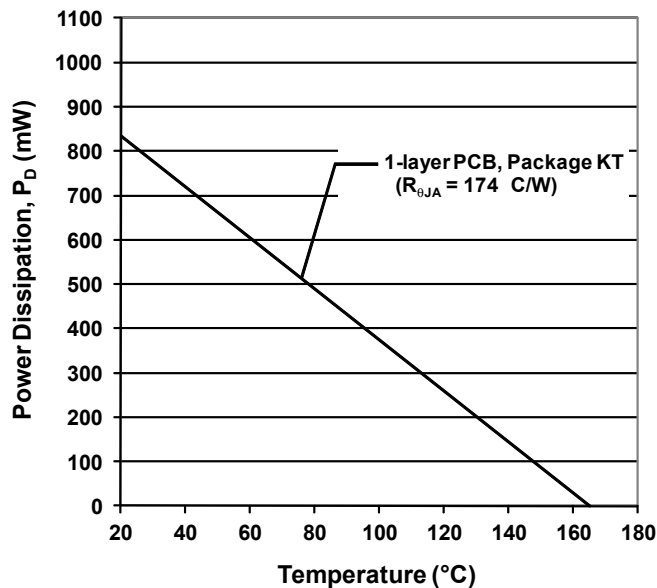

A1340

High Precision Programmable Linear Hall Effect Sensor IC with EEPROM, Analog Output, and Advanced Output Linearization

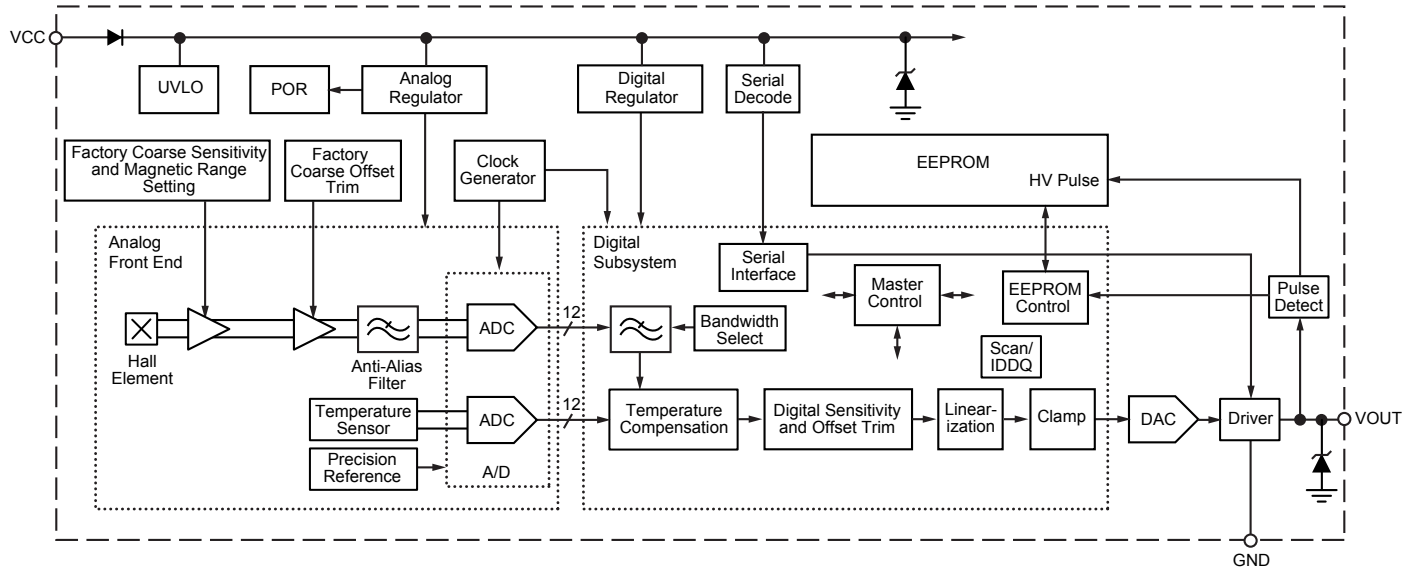

Functional Block Diagram

PINOUT DIAGRAM AND TERMINAL LIST TABLE

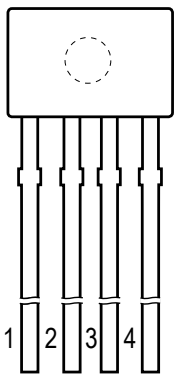

Package KT, 4-Pin SIP

Terminal List Table

Number	Name	Function
1	VCC	Input power supply, use bypass capacitor to connect to ground
2	VOUT	Analog output pin; EEPROM strobe input
3	NC	Not connected; connect to GND for optimal ESD performance
4	GND	Device ground

**ELECTRICAL CHARACTERISTICS: Valid through full operating temperature range, T_A , and supply voltage, V_{CC} ,
 $C_{BYPASS} = 10$ nF, unless otherwise specified**

Characteristics	Symbol	Test Conditions	Min.	Typ.	Max.	Unit [1]
GENERAL ELECTRICAL CHARACTERISTICS						
Supply Voltage	V_{CC}		4.5	–	5.5	V
Supply Current	I_{CC}		5	–	15	mA
Supply Zener Clamp Voltage	$V_{ZSUPPLY}$	$T_A = 25^\circ\text{C}$; $I_{CC} = I_{CC}(\text{max}) + 3$ mA	19	–	–	V
Hall Chopping Frequency [4]	f_C	$T_A = 25^\circ\text{C}$	–	128	–	kHz
Undervoltage Lockout Threshold [2]	$V_{CC(UV_low)}$	$T_A = 25^\circ\text{C}$, UVLO falling	3.5	–	4.2	V
	$V_{CC(UV_high)}$	$T_A = 25^\circ\text{C}$, UVLO rising	3.7	–	4.45	V
OUTPUT ELECTRICAL CHARACTERISTICS						
Output Saturation Voltage	$V_{SAT(H)}$	$R_{OUT} = 10$ k Ω to GND, $V_{CC} - V_{OUT}$, $T_A = 25^\circ\text{C}$	–	0.2	0.3	V
	$V_{SAT(L)}$	$R_{OUT} = 10$ k Ω to V_{CC} , $T_A = 25^\circ\text{C}$	–	0.2	0.3	V
Output Current Limit	$I_{LIMIT(SNK)}$	$V_{OUT} = V_{CC}(\text{max})$, $T_A = 25^\circ\text{C}$	25	35	42	mA
	$I_{LIMIT(SRC)}$	$V_{OUT} = \text{GND}$, $T_A = 25^\circ\text{C}$	–4	–1.6	–	mA
Output Noise Peak to Peak [3]	V_{npp}		–	6	–	mV _{pp}
Output Zener Clamp Voltage	V_{ZOUT}	$T_A = 25^\circ\text{C}$	29	–	–	V
Output Load Resistance [4]	R_{LOAD}	V_{OUT} to V_{CC} , V_{OUT} to GND	10	–	–	k Ω
Output Load Capacitance [4][5]	C_{LOAD}	V_{OUT} to GND	–	–	10	nF
Power-On Time [4][6][7]	t_{PO}	BW = 3000 Hz	–	0.6	0.75	ms
		BW = 1500 Hz	–	1.1	1.4	ms
		BW = 375 Hz	–	3.2	4.0	ms
Response Time [7][8]	t_{RESP}	BW = 3000 Hz	–	0.5	–	ms
		BW = 1500 Hz	–	0.9	–	ms
		BW = 375 Hz	–	3.24	–	ms

[1] 1 G (gauss) = 0.1 mT (millitesla).

[2] See Protection Features section.

[3] Capacitor of 10 nF connected between output and ground.

[4] Determined by design.

[5] Clarity of a Read Acknowledge message from the device to the controller will be affected by the amount of capacitance and wire inductance on the device output. In such case, it is recommended to slow down the communication speed, and to lower the receiver threshold for reading digital Manchester signal to 1 V.

[6] Defined as time from V_{CC} reaching $V_{CC}(\text{min})$ to V_{OUT} reaching 90% of its steady state. See Definitions of Terms section.

[7] Parameter is verified by lab characterization with a limited amount of samples.

[8] Defined time from step in gauss of applied magnetic field to V_{OUT} step reaching 90% of its steady state. See Definitions of Terms section.

MAGNETIC CHARACTERISTICS: Valid across full operating temperature range, T_A , and supply voltage range, V_{CC} ,
 $C_{BYPASS} = 10 \text{ nF}$; unless otherwise specified

Characteristics	Symbol	Test Conditions	Min.	Typ.	Max.	Unit [1]
FACTORY PROGRAMMED DEVICE VALUES [2]						
Magnetic Input Signal Range	B_{IN}	SENS_COARSE = 4	–	±300	–	G
Magnetic Input Signal Offset	$B_{INOFFSET}$	SIG_OFFSET = 0	–	0	–	V
Output Sensitivity	Sens	SENS_MULT = 0, $T_A = 25^\circ\text{C}$	8.08	8.33	8.58	mV/G
Quiescent Voltage Output	$V_{OUT(Q)}$	$B_{IN} = 0 \text{ G}$, $T_A = 25^\circ\text{C}$	2.42	2.50	2.58	V
Output Clamp Initial Voltage	$V_{CLP(H)init}$		–	$V_{CC} - V_{SAT(H)}$	–	V
	$V_{CLP(L)init}$		–	$V_{SAT(L)}$	–	V
Sensitivity Drift Over Temperature [3]	ΔSens	$T_A = -40^\circ\text{C}$ to 25°C	–	<±0.03	–	%/°C
		$T_A = 25^\circ\text{C}$ to 150°C	–	<±0.02	–	%/°C
Offset (QVO) Drift Over Temperature [4]	$\Delta V_{OUT(Q)}$	$T_A = -40^\circ\text{C}$ to 25°C	–	<±0.7	–	mV/°C
		$T_A = 25^\circ\text{C}$ to 150°C	–	<±0.1	–	mV/°C

[1] 1 G (gauss) = 0.1 mT (millitesla).

[2] Device performance is optimized for the input magnetic range of SENS_COARSE = 4 and input offset of SIG_OFFSET=0. If a different magnetic input range or signal offset is required, please see the tables in the section EEPROM Customer-Programmable Parameter Reference, near the end of this document.

[3] Does not include drift over lifetime and package hysteresis.

[4] Offset drifts with temperature changes will be altered from the factory programmed values if Magnetic Input Signal Range is changed. If changes in Magnetic Input Signal Range cannot be avoided because of application requirements, please contact Allegro for detailed information.

PROGRAMMABLE CHARACTERISTICS: Valid through full operating temperature range, T_A , and supply voltage, V_{CC} ,
 $C_{BYPASS} = 10 \text{ nF}$, unless otherwise specified

Characteristics	Symbol	Test Conditions	Min.	Typ.	Max.	Unit [1]
INTERNAL BANDWIDTH PROGRAMMING [2]						
Bandwidth Programming Bits		BW	–	2	–	bit
Bandwidth Programming Range	BW	$T_A = 25^\circ\text{C}$; for programming values, see BW in EEPROM Structure section	375	–	3000	Hz
Bandwidth Post-Programming Tolerance	ΔBW	$T_A = 25^\circ\text{C}$, measured as a percentage of BW	–	± 5	–	%
FINE QUIESCENT VOLTAGE OUTPUT (QVO) [2]						
Fine Quiescent Voltage Output Programming Bits		QVO_FINE	–	12	–	bit
Fine Quiescent Voltage Output Programming Range	QVO_FINE	$T_A = 25^\circ\text{C}$, $B_{IN} = 0 \text{ G}$, $V_{OUT(Q)} = 2.5 \text{ V}$	–1	–	+1	V
Fine Quiescent Voltage Output Programming Step Size	Step _{QVO_FINE}	$T_A = 25^\circ\text{C}$, $B_{IN} = 0 \text{ G}$	–	1.22	–	mV
OUTPUT SENSITIVITY [2]						
Output Sensitivity	SENS_OUT	SENS_COARSE = 4, Measured at $V_{CC} = 5 \text{ V}$, $T_A = 25^\circ\text{C}$	5	–	11.6	mV/G
Sensitivity Multiplier Programming Bits		SENS_MULT	–	12	–	bit
Sensitivity Multiplier Programming Range	SENS_MULT	$T_A = 25^\circ\text{C}$	0	–	2	–
Sensitivity Multiplier Programming Step Size	Step _{SENS_MULT}	$T_A = 25^\circ\text{C}$	–	0.00048	–	–
LINEARIZATION [2]						
Linearization Positions			–	33	–	data sampling point
Linearization Position Coefficient Bits	LINPOS_COEFF	LIN_x, programmed with output fitting method	–	12	–	bit
Output Polarity Bit		LIN_OUTPUT_INVERT	–	1	–	bit
Input Polarity Bit		LIN_INPUT_INVERT	–	1	–	bit

Continued on the next page...

PROGRAMMABLE CHARACTERISTICS (continued): Valid through full operating temperature range, T_A , and supply voltage, V_{CC} , $C_{BYPASS} = 10 \text{ nF}$, unless otherwise specified

Characteristics	Symbol	Test Conditions	Min.	Typ.	Max.	Unit [1]
TEMPERATURE COMPENSATION (TC) [2]						
1 st Order Sensitivity TC Programming Bits		TC1_SENS_CLD, $T_A = -40^\circ\text{C}$	–	8	–	bit
		TC1_SENS_HOT, $T_A = 150^\circ\text{C}$	–	8	–	bit
Typical 1 st Order Sensitivity TC Programming Range [3]	TC1_SENS_CLD TC1_SENS_HOT		–98	–	+291	m%/°C
Typical 1 st Order Sensitivity TC Programming Step Size [3]	Step _{TC1SENS}		–	1.53	–	m%/°C
2 nd Order Sensitivity TC Programming Bits		TC2_SENS_CLD, $T_A = -40^\circ\text{C}$	–	9	–	bit
		TC2_SENS_HOT, $T_A = 150^\circ\text{C}$	–	9	–	bit
Typical 2 nd Order Sensitivity TC Programming Range [4]	TC2_SENS_CLD TC2_SENS_HOT		–1.53	–	+1.53	m%/°C ²
2 nd Order Sensitivity TC Programming Step Size [4]	Step _{TC2SENS}		–	0.00596	–	m%/°C ²
1 st Order Magnetic Offset TC Programming Bits		TC1_OFFSET	–	8	–	bit
Typical 1 st Order Magnetic Offset TC Programming Range	TC1_OFFSET		–122	–	+122	mG/°C
1 st Order Magnetic Offset TC Step Size	Step _{TC1_OFFSET}		–	0.954	–	mG/°C
OUTPUT CLAMPING RANGE [2]						
Clamp Programming Bits		CLAMP_HIGH	–	6	–	bit
		CLAMP_LOW	–	6	–	bit
Output Clamp Programming Range [5]	$V_{CLP(H)}$	CLAMP_HIGH, measured as V_{OUT} , $T_A = 25^\circ\text{C}$, $V_{CC} = 5 \text{ V}$	2.54	–	$V_{CC} - V_{SAT(H)}$	V
	$V_{CLP(L)}$	CLAMP_LOW, measured as V_{OUT} , $T_A = 25^\circ\text{C}$, $V_{CC} = 5 \text{ V}$	$V_{SAT(L)}$	–	2.46	V
Clamp Programming Step Size	Step _{CLP(H)}	Measured as ΔV_{OUT} , $T_A = 25^\circ\text{C}$	–	39	–	mV
	Step _{CLP(L)}	Measured as ΔV_{OUT} , $T_A = 25^\circ\text{C}$	–	39	–	mV

Continued on the next page...

PROGRAMMABLE CHARACTERISTICS (continued): Valid through full operating temperature range, T_A , and supply voltage, V_{CC} , $C_{BYPASS} = 10$ nF, unless otherwise specified

Characteristics	Symbol	Test Conditions	Min.	Typ.	Max.	Unit [1]
ACCURACY						
Linearity Sensitivity Error	Lin_{ERR}		-1	-	1	%
Sensitivity Drift Due to Package Hysteresis	$\Delta Sens_{PKG}$	Variation on final programmed Sensitivity value; measured at $T_A = 25^\circ C$ after temperature cycling from $25^\circ C$ to $150^\circ C$ and back to $25^\circ C$	-	$<\pm 1$	-	%
Sensitivity Drift Over Lifetime	$\Delta Sens_{LIFE}$	$T_A = 25^\circ C$, shift after AEC-Q100 grade 0 qualification testing	-	± 2	-	%
Ratiometry Quiescent Voltage Output Error	$Rat_{VOUTQERR}$		-	$<\pm 0.5$	-	%
Ratiometry Sensitivity Error	$Rat_{SENSERR}$		-	$<\pm 1$	-	%
Ratiometry Clamp Error	Rat_{CLPERR}		-	$<\pm 1$	-	%

[1] 1 G (gauss) = 0.1 mT (millitesla).

[2] Determined by design.

[3] The unit $m\%/C$ means: $(10^{-3} \times \%) / C$.

[4] The unit $m\%/C^2$ means: $(10^{-3} \times \%) / C^2$.

[5] Clamp_High minimum value trim can not be lower than QVO trim. Clamp_Low maximum value trim can not be higher than QVO trim.

CHARACTERISTIC PERFORMANCE

Average Supply Current versus Supply Voltage

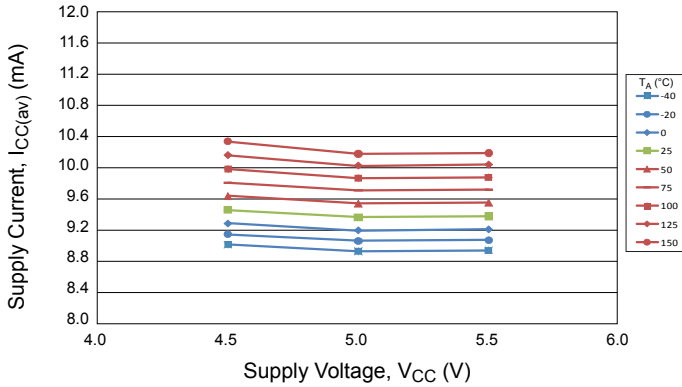

Average Supply Current (On) versus Temperature

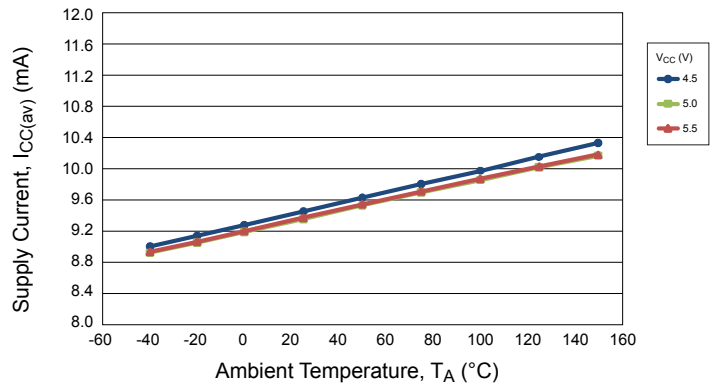

Output Saturation Voltage (Low) versus Average Supply Voltage

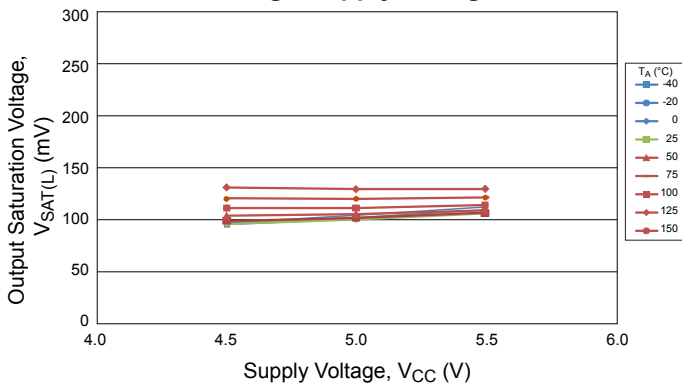

Output Saturation Voltage (Low) versus Average Temperature

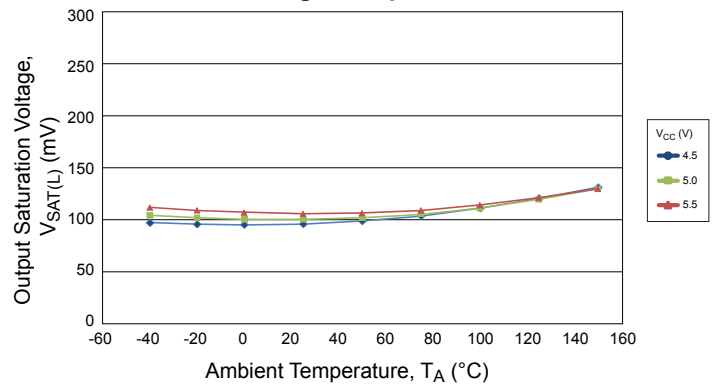

Output Saturation Voltage (High) versus Average Supply Voltage

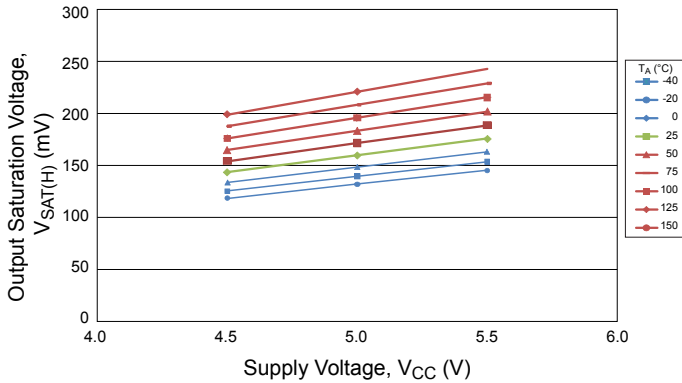

Output Saturation Voltage (High) versus Average Temperature

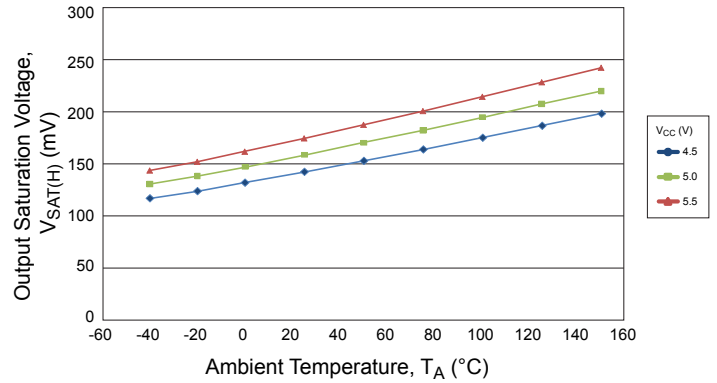

Factory Programmed Sensitivity Drift versus Ambient Temperature

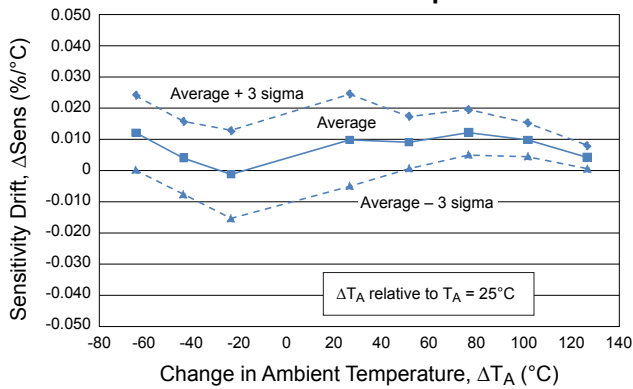

Factory Programmed Sensitivity versus Ambient Temperature

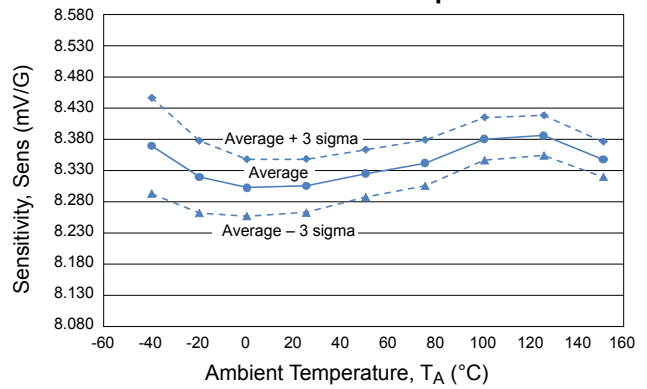

Factory Programmed Quiescent Voltage Output Drift versus Ambient Temperature

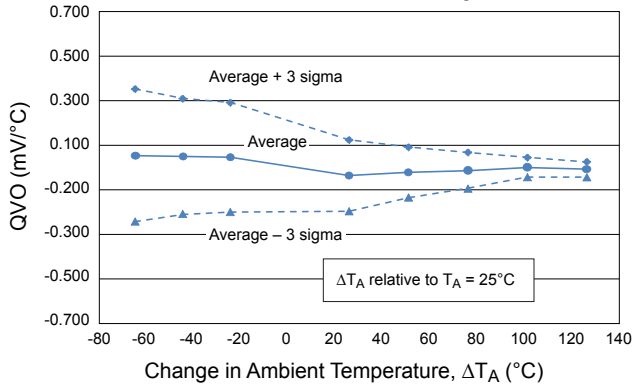

Factory Programmed Quiescent Voltage Output versus Ambient Temperature

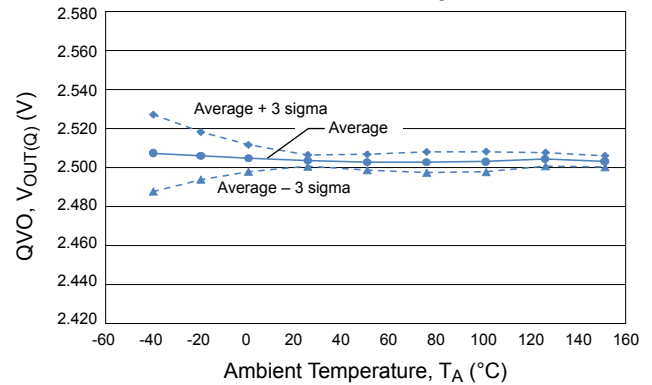

Positive Linearity versus Ambient Temperature

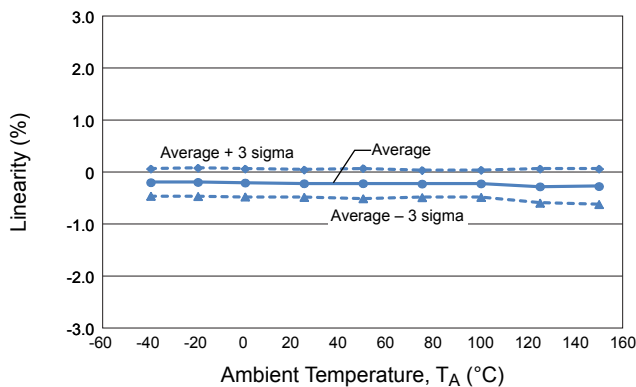

Negative Linearity versus Ambient Temperature

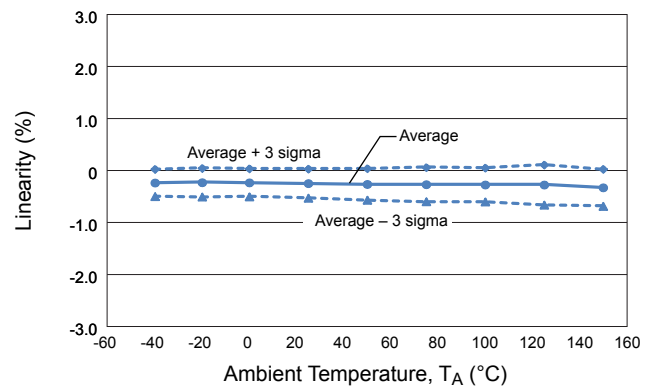

Average Quiescent Voltage Output Ratiometry versus Ambient Temperature

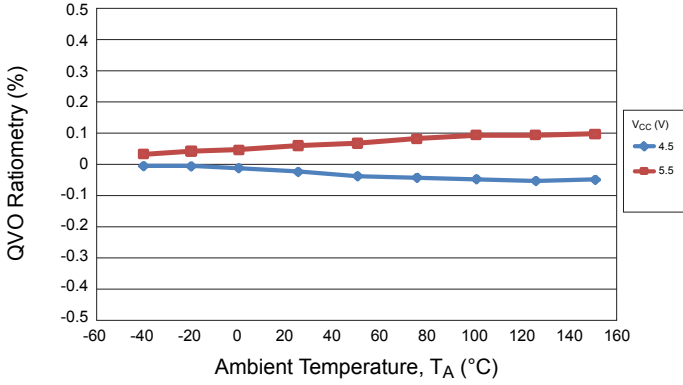

Average Sensitivity Ratiometry versus Ambient Temperature

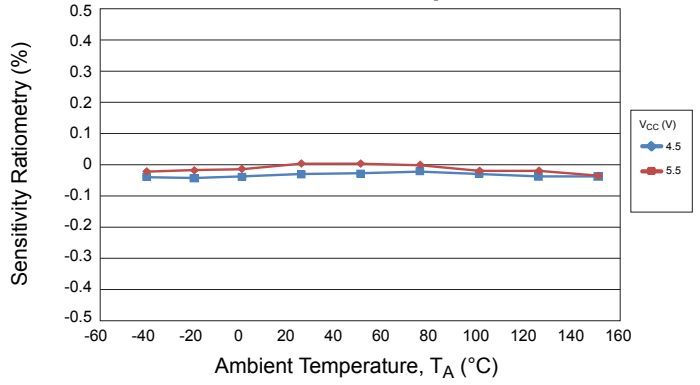

FUNCTIONAL DESCRIPTION

This section provides descriptions of the operating features and subsystems of the A1340. For more information on specific terms, refer to the Definitions of Terms section. Tables of EEPROM parameter values are provided in the EEPROM Structure section.

Signal Processing Parameter Setting

The A1340 has customer-programmable parameters that allow the user to optimize the signal processing performed by the A1340. Customer-programmable parameters apply to digital signal processing (DSP) stage. Programmed settings are stored in onboard EEPROM. The programming communication protocol is described in the Programming Serial Interface section.

The initial analog processing is factory programmed to match the application environment in terms of magnetic field range and offset. This allows optimization of the electrical signal presented to the DSP stage:

$$Y_{AD} (V) = SENS_COARSE (mV/G) \times B_{IN} + SIG_OFFSET (V) + V_{OUT(Q)} \quad (1)$$

where:

Y_{AD} is the output of the analog subsystem to the A-to-D converter,

$SENS_COARSE$ is the factory-set coarse sensitivity,

B_{IN} is the current magnetic input signal,

SIG_OFFSET the factory-set signal offset, and

$V_{OUT(Q)}$ is the quiescent voltage output with no factory compensation.

The DSP stage provides customer-programmable sensitivity (gain) fine offset adjusting, TC processing, bandwidth, clamp, and linearization selection.

Output is a digital voltage signal, proportional to the applied magnetic signal.

Digital Signal Processing

The digitized analog signal is digitally processed to optimize accuracy and resolution for conversion to the device output stage. An advanced linearization feature also is available.

BANDWIDTH SELECTION

The 3-dB bandwidth, BW , determines the frequency at which the DSP function imports data from the analog front end A-to-D converter. It is programmed by setting the BW parameter in the EEPROM. The values chosen for BW and $RANGE$ affect the DSP stage output resolution and the Response Time, t_{RESP} . These tradeoffs are represented in the Electrical Characteristics table, above.

TEMPERATURE COMPENSATION

The magnetic properties of materials can be affected by changes in temperature, even within the rated ambient operating temperature range, T_A . Any change in the magnetic circuit due to temperature variation causes a proportional change in the device output. The device can be compensated internally using the Temperature Compensation (TC) circuitry. TC coefficients can be programmed for Sensitivity and magnetic offset. The effect of temperature is referred to as *drift*.

Table 1: Bandwidth-Related Tradeoffs

Bandwidth Selection, BW (kHz)	DSP Output Resolution (bit)
0.375	12
1.500	11 to 12
3.000	10 to 11

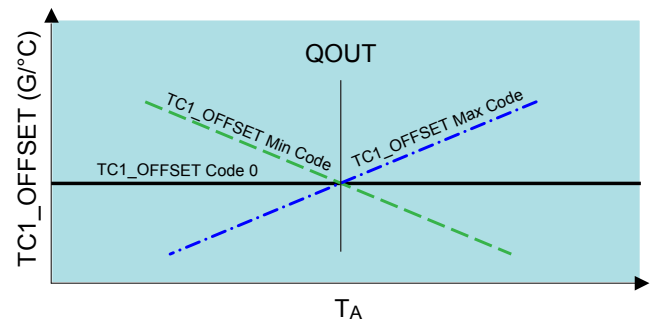

Figure 2: The 1st Order Magnetic Offset Temperature Compensation Coefficient (TC1_OFFSET)

TC1_OFFSET is used for linear adjustment of device output for temperature changes.

For magnetic offset, compensation for 1st Order Magnetic Offset TC, TC1_OFFSET, is a linear algorithm accounting for effects of ambient temperature changes during device operation (see Figure 2). It can be programmed using the TC1_OFFSET parameter in a range of ±122 mG/°C. This compensation is applied in DSP, after bandwidth selection.

Sensitivity drift compensation is customer-programmed (described below), within a framework of programmed temperature compensation. Optional temperature compensation for Sensitivity can be applied using built-in first-order and second-order algorithms. Both approaches adjust the device gain in response to input signal drift by adding or subtracting a value. The coefficients are programmed separately for temperatures above 25°C and below 25°C, as shown in Table 2. The resulting functions are illustrated in figure 4).

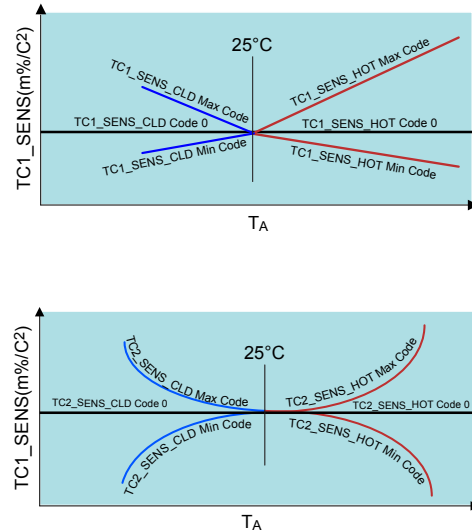

Figure 4: Sensitivity TC Functions:
(upper) first order; (lower) second order

Table 2: Sensitivity Temperature Compensation Options

	T _A Range	
	< 25°C	> 25°C
1 st Order	TC1_SENS_CLD	TC1_SENS_HOT
2 nd Order	TC2_SENS_CLD	TC2_SENS_HOT

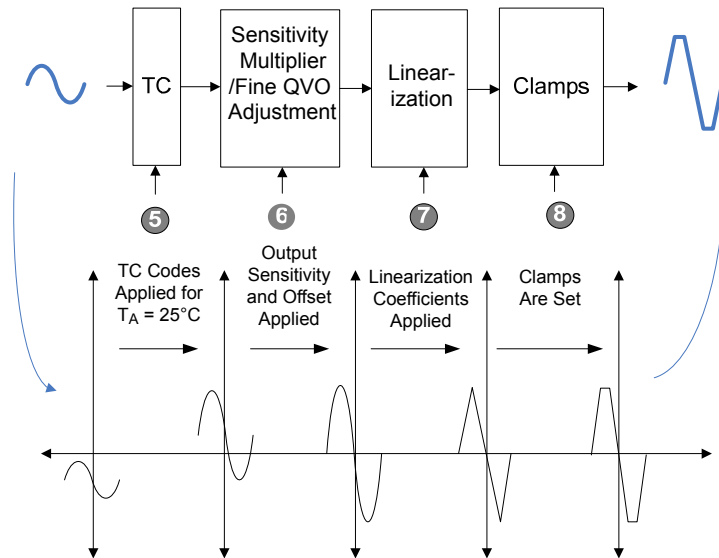

Figure 3: Signal Path for Digital Subsystem

Either first-order or second-order, or both TC algorithms can be applied. To apply an algorithm, select non-zero coefficients for the corresponding EEPROM parameters (TC1_SENS_CLD and TC1_SENS_HOT for first-order, TC2_SENS_CLD and TC2_SENS_HOT for second order). If a method should not be used, set the corresponding EEPROM parameter values to zero. If both are selected, the A1340 applies the first-order, and then the second-order algorithm during this stage.

The programmed values set the temperature compensation, Y_{TC} , according to the following formula:

$$Y_{TC}(V) = Y_{AD}(V) + [(TC1_SENS(m\%/^{\circ}C) \times \Delta T_A(^{\circ}C)) + (TC2_SENS(m\%/^{\circ}C^2) \times \Delta T_A^2(^{\circ}C))] \times (Y_{AD}(V) - SIG_OFFSET(V)) + TC1_OFFSET(G/^{\circ}C) \times SENS_COARSE_COEF \times 5(mV/G) \times \Delta T_A(^{\circ}C) \quad (2)$$

where:

Y_{AD} is the input from the analog subsystem via the A-to-D converter,

TC1_SENS is the first-order coefficient: either TC1_SENS_HOT or TC1_SENS_CLD depending on T_A ,

TC2_SENS is the second-order coefficient: either TC2_SENS_HOT or TC2_SENS_CLD depending on T_A ,

ΔT_A is the change in ambient temperature from 25°C (for example: at 150°C, $\Delta T_A = 150^{\circ}C - 25^{\circ}C = 125^{\circ}C$, or at -40°C, $\Delta T_A = -40^{\circ}C - 25^{\circ}C = -65^{\circ}C$), and

SIG_OFFSET (set to 0) is the factory programmed addition to the magnetic offset parameter (sets the centerpoint of Y_{AD}), and

$SENS_COARSE_COEF = SENS_COARSE_{(code\ 0)}/SENS_COARSE_{(factory\ code)}$ (sets the factory-programmed sensitivity of the Y_{AD} function).

DIGITAL OUTPUT SENSITIVITY (GAIN) ADJUSTMENT

Sensitivity is applied in the DSP subsystem, after bandwidth selection and temperature compensation.

Note: If Sensitivity must be adjusted more than 20% from the nominal value, please consider switching input magnetic range for the optimization of A-to-D input.

OUTPUT FINE OFFSET ADJUSTMENT

The Fine Offset adjustment is the segment of the DSP signal used to trim the device output, V_{OUT} .

QVO_FINE is a customer-programmable parameter that sets the Quiescent Voltage Output, $V_{OUT(Q)}$, which is device output when there is no significant applied magnetic field. The programmed value sets the DSP output, Y_{DA} , taking into account the selected Sensitivity:

$$Y_{DA} = SENS_MULT \times Y_{TC}(V) + QVO_FINE(V) \quad (2)$$

$$SENS_OUT(mV/G) = SENS_MULT \times SENS(mV/G) \quad (3)$$

where SENS_MULT is the multiplication factor from 0.6 to 1.4.

QVO_FINE is set as a percentage of V_{OUT} .

LINEARIZATION OF OUTPUT

Magnetic fields are not always linear throughout the full range of target positions, such as in the case of ring magnet targets rotated in front of a non-back-biased linear Hall sensor IC, shown in Figure 5. The A1340 provides a programmable linearization feature that allows adjustment of the transfer characteristic of the device so that, as the actual position of the target changes, the resulting changes in the applied magnetic field can be output as corresponding linear increments.

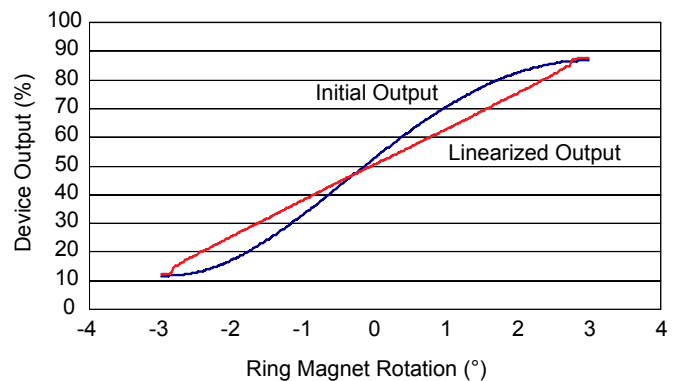

Figure 5: Example of Linearization of a Sinusoidal Magnetic Signal Generated by a Rotating Ring Magnet

In order to achieve this, an initial set of linearization coefficients has to be created. The user takes 33 samples of B_{IN} : at the start and at every 1/32 interval of the full input range. The user then enters these 33 values into the Allegro ASEK programming utility for the A1340, or an equivalent customer software program, and generates coefficients corresponding to the values. The user then uses the software load function to transmit the coefficients to the EEPROM (LINPOS_COEFF parameter). The user then sets the LIN_TABLE_DONE parameter to 1.

Each of the coefficient values can be individually overwritten during normal operation. Figure 6 shows an example input-output curve. The y axis represents the 32 equal full scale position segments, and the x axis represents the the range of movement. When the A1340 is in operation, it applies a linearization curve built from the 33 coefficients provided by the user. For example, at position 5 the device originally would output 384 LSB of magnetic field internal to device before the D-to-A converter. This

384 LSB is treated as input to the inverse linearization function, after rescaling to the x axis as follows:

$$(384 - 128(\text{offset})) \times [32 / (3968(\text{LSBmax}) - 128(\text{LSBmin}))] + 1 = 3.2$$

For $x = 3.2$, the inverse function will give output of 570 LSB which is right on the curve of the linear output signal.

OUTPUT POLARITY

Device Output Polarity can be changed using the linearization table, and the LIN_INPUT_INVERT and LIN_OUT_INVERT bits.

In order to invert the device output polarity with no linearization, the linearization function must be set to gain 1 (linearization table coefficients are decimal values from 0 to 4096 with steps of 128 codes), and one of the bits LIN_INPUT_INVERT or LIN_OUT_INVERT must be set to 1.

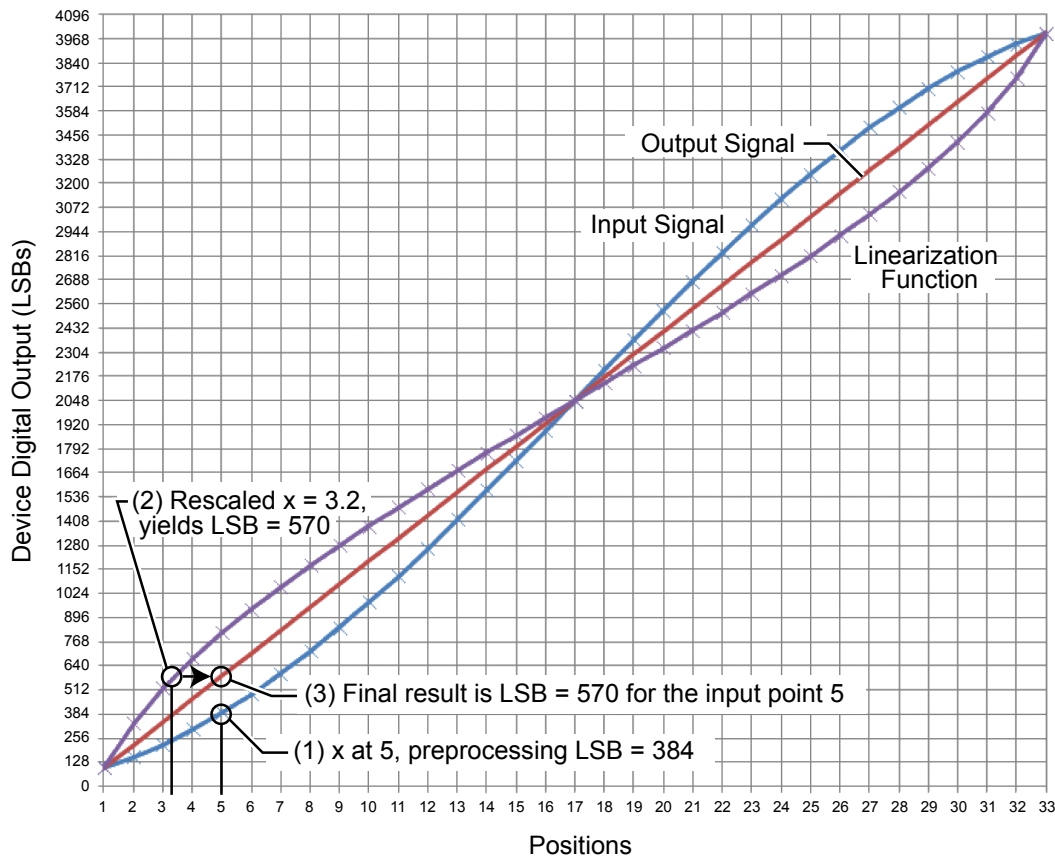

Figure 6: Sample of Linearization Function Transfer Characteristic.

If the goal is to change output polarity and apply linearization, the output polarity should be changed by setting the gain of the linearization function to 1 and setting the LIN_INPUT_INVERT bit to 1. Then user can collect 33 points for linearization and calculate the coefficients. After the coefficients are loaded into the device, successful linearization will be applied by leaving the LIN_INPUT_INVERT bit set to 1 and setting the LIN_TABLE_DONE bit to 1.

OUTPUT SIGNAL CLAMPS SETTING

To eliminate the effects of outlier points, the A1340 Clamp Range, V_{CLP} , is initially set to a high limit of $V_{CC} - V_{sat}$ for high clamp and $0V + V_{sat}$ for low clamp, and can be adjusted using the CLAMP_HIGH and CLAMP_LOW parameters.

PROTECTION FEATURES

Lockout and clamping features protect the A1340 internal circuitry and prevent spurious output when supply voltage is out of specification. Open circuit detection is also provided.

Operating Undervoltage Lockout

Lockout features protect the A1340 internal circuitry and prevent spurious output when V_{CC} is out of specification. Diagnostic circuitry reuses the output pin (VOUT) to provide feedback to the external controller. The A1340 provides lockout protection

for undervoltage on the supply line. Lockout features protect the A1340 internal circuitry and prevent spurious output when V_{CC} is out of specification. Diagnostic circuitry reuses the output pin (VOUT) to provide feedback to the external controller.

If the supply voltage drops below $V_{CC(UV_low)}$ the device internal lockout function isolates the onboard processing circuits and pulls the VOUT pin to a diagnostic level. As the supply voltage rises above $V_{CC(UV_high)}$ the diagnostic condition is removed.

Open Circuit Detection

Diagnostic circuitry reuses the output pin (VOUT) to provide feedback to the external controller if a resistor, R_{OCD} , is placed between VOUT and a separate V_{BAT} or ground reference, as shown in table 3. When an open circuit occurs on any combination of A1340 pins, a corresponding V_{OUT} level is generated.

TYPICAL APPLICATION

Multiple A1340 linear devices can be connected to the external controller as shown in Figure 7. However, EEPROM programming in the A1340 occurs when the external control unit excites the A1340 VOUT pin by EEPROM pulses generated by the ECU. Whichever A1340s are excited by EEPROM pulses on their VOUT pin will accept commands from the controller.

Table 3: Open Circuit Diagnostic Truth Table

	Node A	Node B	Node C	VOUT State
V_{BAT} Referenced				
	Open	Closed	Closed	0 V to V_{BAT}
	Closed	Open	Closed	$V_{OUT(Q)}$
	Open	Open	Closed	GND
	Open	Closed	Open	V_{BAT}
	Closed	Open	Open	V_{CC}
Closed	Closed	Open	V_{CC} to V_{BAT}	
Ground Referenced				
	Closed	Open	Closed	$V_{OUT(Q)}$
	Closed	Closed	Open	0 V to V_{CC}
	Closed	Open	Open	V_{CC}
	Open	Open	Closed	GND
	Open	Closed	Open	GND
Open	Closed	Closed	GND	

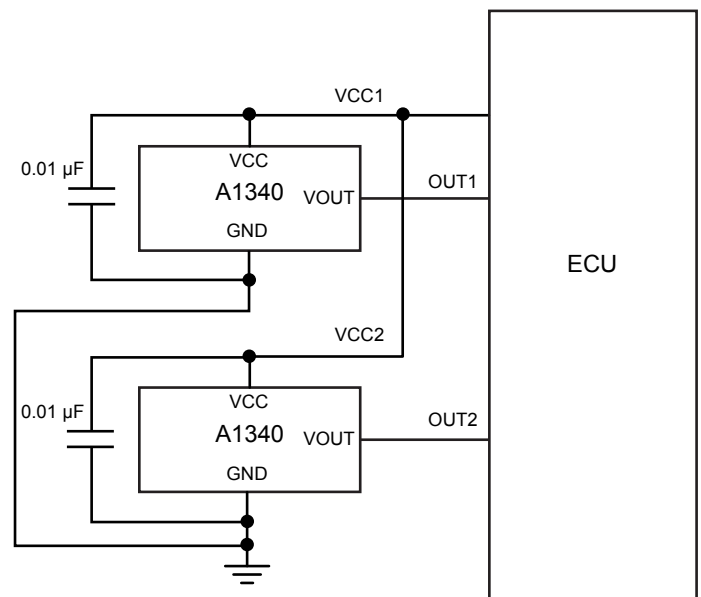

Figure 7: Typical Application with Multiple A1340s

PROGRAMMING SERIAL INTERFACE

The A1340 incorporates a serial interface that allows an external controller to read and write registers in the A1340 EEPROM and volatile memory. The A1340 uses a point-to-point communication protocol, based on Manchester encoding per G. E. Thomas (a rising edge indicates 0 and a falling edge indicates 1), with address and data transmitted MSB first.

Transaction Types

Each transaction is initiated by a command from the controller; the A1340 does not initiate any transactions. Two commands are recognized by the A1340: Write and Read. There also are three special function Write commands: Write Access Code, Write Disable Output, and Write Enable Output. One response frame type is generated by the A1340, Read Acknowledge.

If the command is Read, the A1340 responds by transmitting the requested data in a Read Acknowledge frame. If the command is any other type, the A1340 does not acknowledge.

As shown in Figure 8, The A1340 receives all commands via the VCC pin. It responds to Read commands via the VOUT pin. This implementation of Manchester encoding requires the communication pulses be within a high ($V_{MAN(H)}$) and low ($V_{MAN(L)}$) range of voltages for the VCC line and the VOUT line. The Write command pulses to EEPROM are supported by two high voltage pulses on the VOUT line.

Writing the Access Code

If the external controller will write to or read from the A1340 memory during the current session, it must establish serial communication with the A1340 by sending a Write command including the Access Code within 70 ms after powering up the A1340. If this deadline is missed, all write and read access is disabled until the next power-up.

Writing to Non-Volatile EEPROM

When a Write command requires writing to non-volatile EEPROM (all standard Writes), after the Write command the controller must also send two *Programming pulses*, well-separated, long high-voltage strobcs via the VOUT pin. These strobcs are detected internally, allowing the A1340 to boost the voltage on the EEPROM gates.

To ensure these strobcs are properly received, the controller must suppress the normal device output on the VOUT pin (that is, the linear output voltage in response to magnetic field input). To do so, the external controller sends a Write Disable Output command before transmitting the strobcs. This puts the VOUT pin into a high impedance state. After writing is complete, the controller must send an Write Enable Output command to restore VOUT to normal operation. The required sequence is shown in Figure 9.

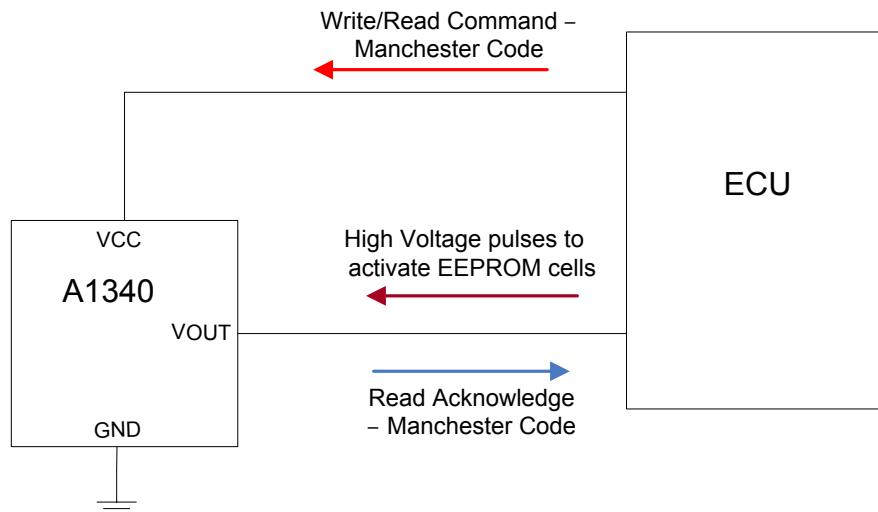

Figure 8: Top-Level Programming Interface

Writing to Volatile Registers

Writing to the volatile register 0x24 is done for Write Access Code, Write Disable Output, and Write Enable Output commands. This requires the external controller to send the Write command on the VCC pin. Successive Write commands to volatile memory must be separated by t_{WRITE} . The required sequence is shown in Figure 9.

Reading from EEPROM

For proper reading from the A1340, it is recommended that the output be disabled before a Read command is sent. Otherwise the external controller may continue to track the magnetic field input until the first edge of the Read Acknowledge frame. In that case the controller would be required to distinguish between the output associated with the magnetic field and the response to the Read command.

To disable output, the external controller sends a Write Disable Output command before transmitting the Read command. This puts the VOUT pin into a high impedance state. After writing is complete, the controller must send a Write Enable Output command to restore VOUT to normal operation. After the Read

Acknowledge frame has been received from the A1340, the controller must send a Write Enable Output command to restore VOUT to normal operation. The required sequence is shown in Figure 9.

Error Checking

The serial interface uses a cyclic redundancy check (CRC) for data-bit error checking (synchronization bits are ignored during the check).

The CRC algorithm is based on the polynomial

$$g(x) = x^3 + x + 1,$$

and the calculation is represented graphically in Figure 10.

The trailing 3 bits of a message frame comprise the CRC token. The CRC is initialized at 111.

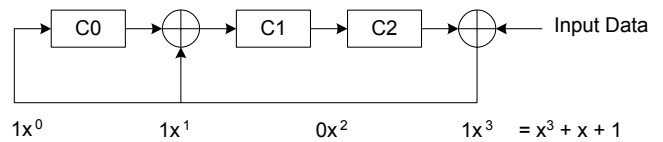

Figure 10: CRC Calculation

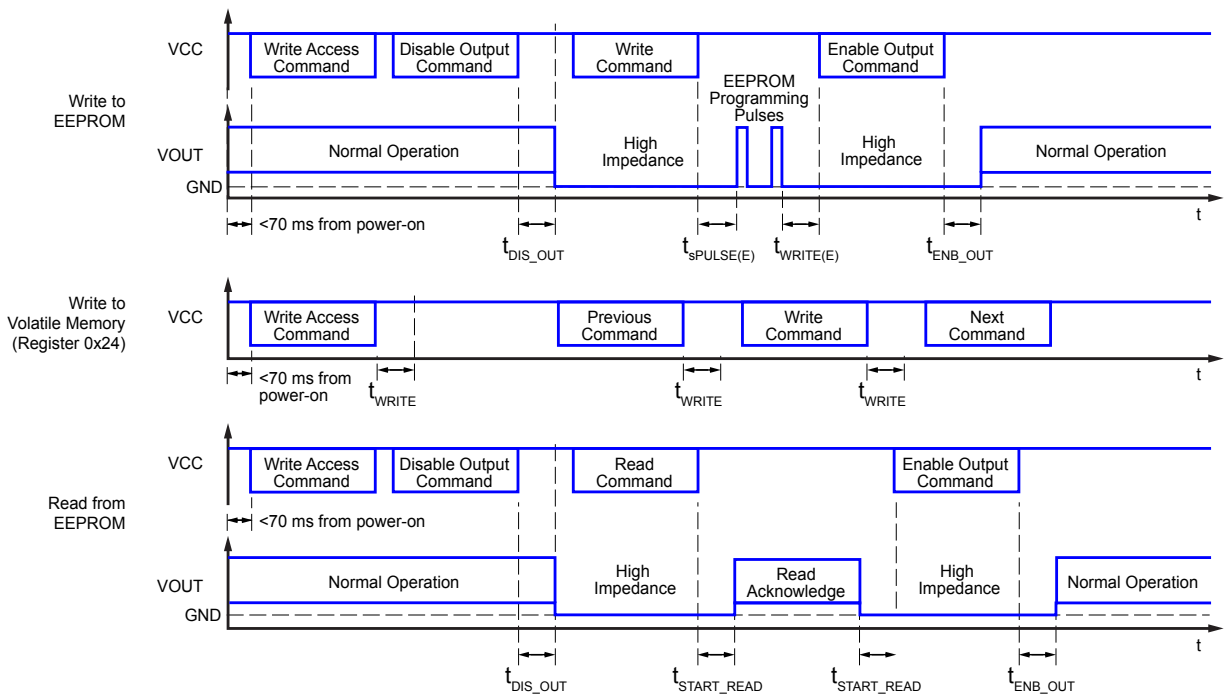

Figure 9: Programming Read and Write Timing Diagrams

(see Serial Interface Reference section for definitions)

Serial Interface Reference

Table 4: Serial Interface Protocol Characteristics [1]

Characteristics	Symbol	Note	Min.	Typ.	Max.	Unit
INPUT/OUTPUT SIGNAL TIMING						
Access code Time Out	t_{acc}	Customer Access Code should be fully entered in less than t_{ACC} , measured from when V_{CC} crosses $V_{CC(UV_high)}$.	–	–	70	ms
Baud Rate		Defined by the input message bit rate sent from the external controller	5	–	100	kbps
Bit Time	t_{BIT}	Data bit pulse width at 5 kbps	195	200	205	μs
		Data bit pulse width at 100 kbps	9.5	10	10.5	μs
Bit Time Error	err_{TBIT}	Deviation in t_{BIT} during one command frame	–11	–	+11	%
Volatile Memory Write Delay	t_{WRITE}	Required delay from the trailing edge of certain Write command frames to the leading edge of a following command frame	$2 \times t_{BIT}$	–	–	μs
Non-Volatile Memory Write Delay	$t_{WRITE(E)}$	Required delay from the trailing edge of the second EEPROM Programming pulse to the leading edge of a following command frame	$2 \times t_{BIT}$	–	–	μs
Read Acknowledge Delay	t_{READ}	Required delay from the trailing edge of a Read Acknowledge frame to the leading edge of a following command frame	$2 \times t_{BIT}$	–	–	μs
Read Delay [2]	t_{START_READ}	Delay from the trailing edge of a Read command frame to the leading edge of the Read Acknowledge frame	$25 \mu s - 0.25 \times t_{BIT}$	$50 \mu s - 0.25 \times t_{BIT}$	$150 \mu s - 0.25 \times t_{BIT}$	μs
Disable Output Delay [2]	t_{DIS_OUT}	Delay from the trailing edge of a Disable Output command frame to the device output going from normal operation to the high impedance state	$1 \mu s - 0.25 \times t_{BIT}$	$5 \mu s - 0.25 \times t_{BIT}$	$15 \mu s - 0.25 \times t_{BIT}$	μs
Enable Output Delay [2]	t_{ENB_OUT}	Delay from the trailing edge of an Enable Output command frame to the device output going from the high impedance state to normal operation	$1 \mu s - 0.25 \times t_{BIT}$	$5 \mu s - 0.25 \times t_{BIT}$	$15 \mu s - 0.25 \times t_{BIT}$	μs
EEPROM PROGRAMMING PULSE						
EEPROM Programming Pulse Setup Time	$t_{SPULSE(E)}$	Delay from last edge of write command to start of EEPROM programming pulse	40	–	–	μs
INPUT/OUTPUT SIGNAL VOLTAGE						
Manchester Code High Voltage	$V_{MAN(H)}$	Applied to VCC line	7.3	–	–	V
		Read from VOUT line	$V_{CC} - V_{SAT(H)}$	–	–	V
Manchester Code Low Voltage	$V_{MAN(L)}$	Applied to VCC line	–	–	5.7	V
		Read from VOUT line	–	–	$V_{SAT(L)}$	V

[1] Determined by design.

[2] In the case where a slower baud rate is used, the output responds before the transfer of the last bit in the command message is completed.

Serial Interface Message Structure

The general format of a command message frame is shown in Figure 11. Note that, in the Manchester coding used, a bit value of 1 is indicated by a falling edge within the bit boundary, and a bit value of zero is indicated by a rising edge within the bit boundary.

The bits are described in Table 5.

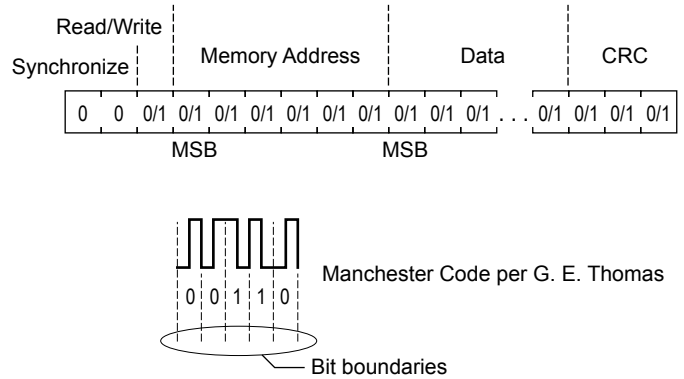

Figure 11: General Format for Serial Interface Commands

Table 5: Serial Interface Command General Format

Quantity of Bits	Parameter Name	Values	Description
2	Synchronization	00	Used to identify the beginning of a serial interface command
1	Read/Write	0	[As required] Write operation
		1	[As required] Read operation
6	Address	0/1	[Read/Write] Register address (volatile memory or EEPROM)
Variable	Data	0/1	[As required] 30 bits of data
3	CRC	0/1	Incorrect value indicates errors

The following command messages can be exchanged between the device and the external controller:

- Read
- Read Acknowledge
- Write
- Write Access Code
- Write Disable Output
- Write Enable Output

For EEPROM address information, refer to the EEPROM Structure section.

READ

Function	Provides the address in A1340 memory to be accessed to transmit the contents to the external controller in the next Read Acknowledge command. A timely Write Access Code command is required once, at power-up of the A1340.
Syntax	Sent by the external controller on the A1340 VCC pin. Sent after a Write Disable Output command.
Related Commands	Read Acknowledge
Pulse Sequence	<p style="text-align: center;"> Read/Write Synchronize Memory Address CRC 0 0 1 0/1 0/1 0/1 0/1 0/1 0/1 0/1 0/1 0/1 MSB </p>
Options	None
Examples	Address in non-volatile memory: 0XXXXX Address in volatile memory: 100100 (Register 0x24)

READ ACKNOWLEDGE

Function	Transmits to the external controller data retrieved from the A1340 memory in response to the most recent Read command.
Syntax	Sent by the A1340 on the A1340 VOUT pin. Sent after a Read command and before a Write Enable Output command.
Related Commands	Read
Pulse Sequence	
Options	If EEPROM Error Checking and Correction (ECC) is not disabled by factory programming, the 6 MSBs are EEPROM data error checking bits. Refer to the EEPROM Structure section for more information.
Examples	–

WRITE

Function	Transmits to the A1340 data prepared by the external controller.
Syntax	Sent by the external controller on the A1340 VCC pin. A timely Write Access Code command is required once, at power-up of the A1340. For writing to non-volatile memory: Sent after a Write Disable Output command.
Related Commands	Disable Output, Enable Output, Write Access Code
Pulse Sequence	
Options	–
Examples	Address in non-volatile memory: 0XXXXX Address in volatile memory: 100100 (Register 0x24)

A1340

High Precision Programmable Linear Hall Effect Sensor IC with EEPROM, Analog Output, and Advanced Output Linearization

WRITE ACCESS CODE

Function	Transmits the Access Code to the A1340; data prepared by the external controller, but must match the internal 30-bit code in the A1340 memory.
Syntax	Sent by the external controller on the A1340 VCC pin. Sent within 70 ms of A1340 power-on, and before any other command.
Related Commands	
Pulse Sequence	
Options	None
Examples	Standard Customer Access Code: 0x2781_1F77 to address 0x24

WRITE DISABLE OUTPUT

Function	Suppresses normal output from the VOUT pin to allow clear transmission of Read Acknowledge commands and EEPROM Programming pulses. Places VOUT in a high impedance state.
Syntax	Sent by the external controller on the A1340 VCC pin. For writing to non-volatile memory: Sent before each Write command. For reading: Sent before a Read command.
Related Commands	Write Enable Output
Pulse Sequence	
Options	None
Examples	0x10 to address 0x24

WRITE ENABLE OUTPUT

Function	Restores normal output from the VOUT pin after a high impedance state has been imposed by a Disable Output command.
Syntax	Sent by the external controller on the A1340 VCC pin. For writing to non-volatile memory: Sent after a Write command and corresponding EEPROM Programming pulses. For reading: Sent after a Read Acknowledge command.
Related Commands	Write Disable Output
Pulse Sequence	
Options	None
Examples	0x0 to address 0x24

EEPROM STRUCTURE

Programmable values are stored in an onboard EEPROM, including both volatile and non-volatile registers. Although it is separate from the digital subsystem, it is accessed by the digital subsystem EEPROM Controller module.

The EEPROM is organized as 30-bit wide words, and by default each word has 24 data bits and 6 ECC (Error Checking and Correction) check bits, stored as shown in Figure 12.

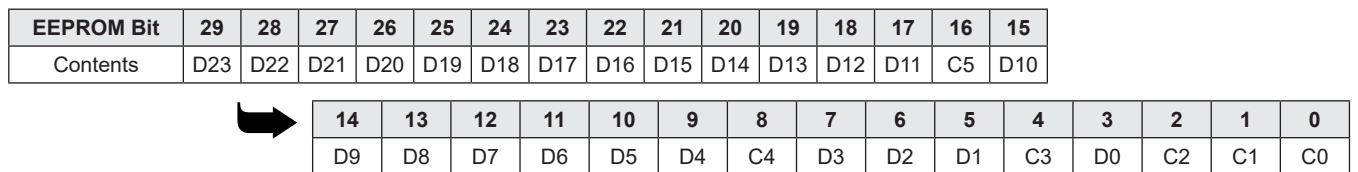

Figure 12: EEPROM Word Bit Sequence; C# – Check Bit, D# – Data Bit

Table 6: EEPROM Register Map of Customer-Programmable Parameters (Non-Volatile Memory)

Address	Bits	Parameter Name	Description	DAC profile
0x08	23:15	TC2_SENS_HOT	2 nd Order Sensitivity Temperature Coefficient, ΔT (from 25°C) > 0	Two's complement
0x08	14:6	TC2_SENS_CLD	2 nd Order Sensitivity Temperature Coefficient, ΔT (from 25°C) < 0	Two's complement
0x08	5:2	SENS_COARSE	Factory Adjustment of the Magnetic Input Signal Range	Non-uniform
0x08	1:0	BW	Internal Bandwidth	Non-uniform
0x09	23:16	TC1_SENS_HOT	1 st Order Sensitivity Temperature Coefficient, ΔT (from 25°C) > 0	Non-uniform
0x09	15:8	TC1_SENS_CLD	1 st Order Sensitivity Temperature Coefficient, ΔT (from 25°C) < 0	Non-uniform
0x09	7:0	TC1_OFFSET	1 st Order Magnetic Offset Drift Compensation	Two's complement
0x0A	23:12	SCRATCH_C	Customer Scratchpad	
0x0A	11:0	SENS_MULT	Output Sensitivity/ Sensitivity Multiplier	
0x0B to 0x1A	23:12	LINPOS_COEFF (LIN_1, LIN_3, ..., LIN_31)	Linearization Coefficients (odd-numbered sampling positions)	
0x0B to 0x1B	11:0	LINPOS_COEFF (LIN_0, LIN_2, ..., LIN_32)	Linearization Coefficients (even-numbered sampling positions)	
0x1B	23	LIN_TABLE_DONE	Linearization Complete Flag	
0x1B	22	LIN_OUTPUT_INVERT	Linearization Output Polarity Inversion	
0x1B	21	LIN_INPUT_INVERT	Linearization Input Polarity Inversion	
0x1B	20:12	ID	Customer Identification Number	
0x1C	23:18	CLAMP_HIGH	Clamp Upper Limit	
0x1C	17:12	CLAMP_LOW	Clamp Lower Limit	
0x1C	11	EEPROM_LOCK ^[1]	Customer EEPROM Lock	
0x1C	10	Reserved	Reserved for system use (customer should not write this bit)	
0x1C	9	OPEN_DRAIN	Disable Internal Pullups on Digital Output Signals	
0x1C	8:4	SIG_OFFSET	Factory Adjustment of Input Signal Offset	Two's complement
0x1C	3:2	Reserved	Reserved for System Use (bits written here will not affect device performance)	
0x1C	1	Reserved	Reserved for system use (customer should not write this bit)	
0x1C	0	Reserved	Reserved for system use (customer should not write this bit)	
0x1D	23:12	SCRATCH_C	Customer Scratchpad	
0x1D	11:0	QVO_FINE	Fine Quiescent Voltage Output (QVO)	Two's complement

^[1] Customer EEPROM lock allows the customer to lock the EEPROM registers from any further changes for the life of the device. Memory reading is still possible after the EEPROM lock bit is set. In the case that a write command is sent to the device by accident after the EEPROM lock, the device needs to be repowered to be accessible again for memory read.

EEPROM Customer-Programmable Parameter Reference

BW (Register Address: 0x08, bits 1:0)

Function	Filter Bandwidth Selects the filter bandwidth (3-dB frequency) for the digitized applied magnetic field signal, applied when passed to the digital system after analog front-end processing.
Syntax	Quantity of bits: 2
Related Commands	–
Values	00: 1500 Hz (Default) 01: (Factory use only) 10: 375 Hz 11: 3000 Hz
Options	–
Examples	–

CLAMP_HIGH (Register Address: 0x1C, bits 23:18)

Function	Clamp Upper Limit Sets the maximum valid output value.
Syntax	Quantity of bits: 6
Related Commands	CLAMP_LOW
Values	000000: $5\text{ V} - V_{\text{sat}}$ (Default) 111111: 2.5 V for $V_{\text{CC}} = 5\text{ V}$
Options	The default, $V_{\text{CLP(H)init}}$, is used if this parameter is not set.
Examples	When ratiometry is on (RATIOM_OFF = 0): Range is $V_{\text{CC}} / 2$, up to $V_{\text{CC}} - V_{\text{sat}}$. When ratiometry is off (RATIOM_OFF = 1): Typical value is $V_{\text{CC}} - 0.5 \times V_{\text{CC}} \times (\text{CLAMP_HIGH} / 64)$

CLAMP_LOW (Register Address: 0x1C, bits 17:12)

Function	Clamp Lower Limit Sets the minimum valid output value.
Syntax	Quantity of bits: 6
Related Commands	CLAMP_HIGH
Values	000000: 0 V + V_{sat} (Default) 111111: 2.5 V for $V_{CC} = 5$ V
Options	The default, $V_{CLP(L)_{init}}$, is used if this parameter is not set.
Examples	When ratiometry is on (RATIOM_OFF = 0): Range is $V_{CC} / 2$, down to V_{sat} . When ratiometry is off (RATIOM_OFF = 1): Typical value is 0 V + $0.5 \times V_{CC} \times (CLAMP_LOW / 64)$

ID (Register Address: 0x1B, bits 20:12)

Function	Customer Identification Number Available register for identifying the A1340 for multiple-unit applications.
Syntax	Quantity of bits: 12
Related Commands	SCRATCH_C
Values	Free-form
Options	–
Examples	–

LIN_INPUT_INVERT (Register Address: 0x1B, bit 21)

Function	Inverts the polarity of the input signal before it is sent into the linearization block. This setting is effective only if LIN_TABLE_DONE is set to 1.
Syntax	Quantity of bits: 1
Related Commands	LIN_x, LIN_OUTPUT_INVERT
Values	0: No inversion of signal before input into the linearization block. 1: Input signal inverted before it is sent into the linearization block.
Options	–
Examples	–

LIN_OUTPUT_INVERT (Register Address: 0x1B, bit 22)

Function	Inverts the polarity of the input signal after the linearization block. This setting is effective only if LIN_TABLE_DONE is set to 1.
Syntax	Quantity of bits: 1
Related Commands	LIN_x, LIN_INPUT_INVERT
Values	0: No inversion of signal after processing in the linearization block. 1: Input signal inverted after processing in the linearization block.
Options	–
Examples	–

LINPOS_COEFF

(LIN_0, LIN_2, ..., LIN_32) (Register Address: 0x0B to 0x1B, bits 11:0)

(LIN_1, LIN_3, ..., LIN_31) (Register Address: 0x0B to 0x1A, bits 23:12)

Function	Linearization Coefficients These addresses are available to store customer-generated and loaded coefficients used for linearization of the temperature-compensated and offset digital signal. Note: These are not used by the device unless the LIN_TABLE_DONE bit is set.							
Syntax	Quantity of bits: 12 (each) LIN_x corresponds to Input Sample B _{INx} Coefficient data stored in two's complement format Values must be monotonically increasing							
Related Commands	LIN_INPUT_INVERT, LIN_OUTPUT_INVERT, LIN_TABLE_DONE							
Values	Calculated according to applied magnetic field							
Options	Input Sample	Output Position	EEPROM Address	Bits	Input Sample	Output Position	EEPROM Address	Bits
	B _{IN0}	-2048	0x0B	11:00	B _{IN16}	0	0x13	11:00
	B _{IN1}	-1920	0x0B	23:12	B _{IN17}	128	0x13	23:12
	B _{IN2}	-1792	0x0C	11:00	B _{IN18}	256	0x14	11:00
	B _{IN3}	-1664	0x0C	23:12	B _{IN19}	384	0x14	23:12
	B _{IN4}	-1536	0x0D	11:00	B _{IN20}	512	0x15	11:00
	B _{IN5}	-1408	0x0D	23:12	B _{IN21}	640	0x15	23:12
	B _{IN6}	-1280	0x0E	11:00	B _{IN22}	768	0x16	11:00
	B _{IN7}	-1152	0x0E	23:12	B _{IN23}	896	0x16	23:12
	B _{IN8}	-1024	0x0F	11:00	B _{IN24}	1024	0x17	11:00
	B _{IN9}	-896	0x0F	23:12	B _{IN25}	1152	0x17	23:12
	B _{IN10}	-768	0x10	11:00	B _{IN26}	1280	0x18	11:00
	B _{IN11}	-640	0x10	23:12	B _{IN27}	1408	0x18	23:12
	B _{IN12}	-512	0x11	11:00	B _{IN28}	1536	0x19	11:00
	B _{IN13}	-384	0x11	23:12	B _{IN29}	1664	0x19	23:12
	B _{IN14}	-256	0x12	11:00	B _{IN30}	1792	0x1A	11:00
	B _{IN15}	-128	0x12	23:12	B _{IN31}	1920	0x1A	23:12
				B _{IN32}	2047	0x1B	11:00	
Examples	–							

LIN_TABLE_DONE (Register Address: 0x1B, bit 23)

Function	Linearization Table Loaded Set by the customer to indicate custom coefficients have been loaded (into the LINPOS_COEFF area of EEPROM). When this flag is set, the device uses the customer coefficients for output linearization. Allows correction for targets that generate non-linear magnetic fields.
Syntax	Quantity of bits: 1
Related Commands	LINPOS_COEFF
Values	0: Linearization algorithm applies default coefficients to the processed signal (Default) 1: Linearization algorithm applies customer-loaded coefficients to the processed signal
Options	–
Examples	–

OPEN_DRAIN (Register Address: 0x1C, bit 9:0)

Function	Output Digital Signal Pullup Disable Switches off internal pullup resistors when digital serial data is being transmitted and uses customer pullup. (Does not affect transmission of normal magnetic data transmission).
Syntax	Quantity of bits: 1
Related Commands	–
Values	0: Internal output pullup enabled at all times (Default) 1: Disable internal output pullup during transmission of digital serial data
Options	–
Examples	–

QVO_FINE (Register Address: 0x1D, bits 11:0)

Function	Quiescent Voltage Output (QVO) Adjusts the device normal output (voltage response to applied magnetic field) to set the baseline output level: for a quiescent applied magnetic field ($B_{IN} \approx 0$ G).
Syntax	Quantity of bits: 12 Code stored in two's complement format
Related Commands	SIG_OFFSET
Values	0111 1111 1111: +49.98% of output full scale range (Default) 1000 0000 0000: –50% of output full scale range
Options	The default, $V_{OUT(Q)}$, is used if this parameter is not set.
Examples	–

RATIOM_OFF (Register Address: 0x1C, bit 11)

Function	Output Ratiometry Disable
Syntax	Quantity of bits: 1
Related Commands	–
Values	<p>0: Ratiometry enabled (Default) The output is determined by: $V_{OUT} = 0.5 \times V_{CC} \times [(B_{IN} / RANGE (G))+1]$</p> <p>1: Ratiometry disabled The output is determined by: $V_{OUT} = 2.5 (V) \times [(B_{IN} / RANGE (G))+1]$</p> <p>RANGE defined in SENS_COARSE table below.</p>
Options	–
Examples	–

SCRATCH_C (Register Address: 0x1D, bits 23:12)

Function	Customer Scratchpad For optional customer use in storing values in the device.
Syntax	Quantity of bits: 12
Related Commands	ID
Values	Free-form field
Options	–
Examples	–

SENS_COARSE (Register Address: 0x08, bits 5:2)

Note: If the Coarse Sensitivity is changed, the offset drifts with temperature changes will be altered from the factory programmed values. If changing Coarse Sensitivity cannot be avoided because of application requirements, please contact Allegro for detailed information.

Function	Coarse Sensitivity Sets the nominal (coarse) sensitivity of the device, SENS_COARSE, which can be defined as $\Delta V_{OUT}/\Delta B_{IN}$. Selection determines the RANGE, the extent of the applied magnetic flux intensity, B_{IN} , sampled for signal processing. (Use SIG_OFFSET to adjust the B_{IN} level at which RANGE is centered.)		
Syntax	Quantity of bits: 4		
Related Commands	SIG_OFFSET, SENS_OUT		
Values		Coarse Sensitivity at $V_{CC} = 5\text{ V}$ (Typical) (mV/G)	RANGE (G)
	Code		
	0000 (Default)	5.00	±500
	0001	16.70	±150
	0010	12.50	±200
	0011	10.00	±250
	0100	8.30	±300
	0101	6.25	±400
	0110	4.00	±625
	0111	3.30	±750
	1000	2.80	±875
	1001	2.50	±1000
	1010	2.00	±1250
	1011	1.67	±1500
1100	1.43	±1750	
1101	1.25	±2000	
1110	25.00	±100	
1111	1.11	±2250	
Options	–		
Examples	To set a sampled B_{IN} range of 500 G, set RANGE = ±250 G (SENS_COARSE = 0011). That would also set Coarse Sensitivity to 10 mV/G (SENS_COARSE = 0011).		

SENS_MULT (Register Address: 0x0A, bits 11:0)

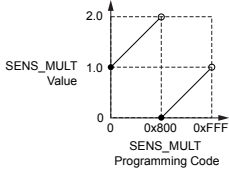
Function	Sensitivity Multiplier After temperature compensation, establishes the gain of the device in normal output (response to a change in the applied magnetic field) by indicating a multiplier value.
Syntax	Quantity of bits: 12 
Related Commands	RANGE, TC1_SENS_CLD, TC1_SENS_HOT, TC2_SENS_CLD, TC2_SENS_HOT
Values	RANGE: ±300 G SENS_COARSE: 8.33 mV/G
Options	SENS_OUT = SENS_COARSE, that is, SENS_MULT = 1 (code 0) if this parameter is not set.
Examples	–

SIG_OFFSET (Register Address: 0x1C, bits 8:4)

Note: If changing Coarse Magnetic Offset cannot be avoided because of application requirements, please contact Allegro for detailed information.

Function	<p>Magnetic Offset Compensation (Coarse) Adjusts the center of the selected RANGE to adapt to the application magnetic field. (The applied offset, QVO_COARSE, is the sum of the selected SIG_OFFSET and a $V_{OUT(Q)}$ factor that compensates for the magnetic back-biasing of the device.) The offset values are expressed in terms of a percentage of the full scale of the selected RANGE and as a voltage relative to $V_{OUT(Q)}$. Note: This is an analog domain variable, so step size is variable, and the offset values shown here represent the expected typical value for the programmed code.</p>		
Syntax	<p>Quantity of bits: 5 Code stored in two's complement format.</p>		
Related Commands	<p>RANGE, TC1_OFFSET</p>		
Values	Code	SIG_OFFSET (% of Full-Scale RANGE)	SIG_OFFSET (Typical) (ΔV)
	00000 (Default)	0.00	0.00
	00001	6.25	0.31
	00010	12.50	0.63
	00011	18.75	0.94
	00100	25.00	1.25
	00101	31.25	1.56
	00110	37.50	1.88
	00111	43.75	2.19
	01000	50.00	2.50
	01001	56.25	2.81
	01010	62.75	3.13
	01011	68.75	3.44
	01100	75.00	3.75
	01101	81.25	4.06
	01110	87.50	4.38
	01111	93.75	4.69
	10000	-100.00	-5.00
	10001	-93.75	-4.69
	10010	-87.50	-4.38
	10011	-81.25	-4.06
	10100	-75.00	-3.75
	10101	-68.75	-3.44
	10110	-62.50	-3.13
	10111	-56.25	-2.81
	11000	-50.00	-2.50
	11001	-43.75	-2.19
	11010	-37.50	-1.88
	11011	-31.25	-1.56
	11100	-25.00	-1.25
	11101	-18.75	-0.94
	11110	-12.50	-0.63
	11111	-6.25	-0.31
Options	<p>The default, $V_{OUT(Q)}$, is used if this parameter is not set.</p>		
Examples	<p>To set the input range from 0 to 1000 G, with a centerpoint at +500 G:</p> <ol style="list-style-type: none"> If SENS_COARSE at 5 mV/G (SENS_COARSE code = 0000). This establishes a full scale input RANGE of 1000 G. The full scale input value, 1000 G, is used as the start point of the offset, so: $\text{SIG_Offset} = (\text{Centerpoint} - \text{Full scale input}) / \text{Full scale input}$ $= 100 \times (500 - 1000) / 1000 = -50\%$ Set the SIG_OFFSET code to 11000 (24), to select SIG_OFFSET = -50%. This also has the effect of setting SIG_OFFSET = -2.5 V. 		

TC1_OFFSET (Register Address: 0x09, bits 7:0)

Function	1st Order Magnetic Offset Temperature Compensation coefficient.
Syntax	Quantity of bits: 8 Code stored in two's complement format.
Related Commands	SIG_OFFSET, TC1_SENS_CLD, TC1_SENS_HOT, TC2_SENS_CLD, TC2_SENS_HOT
Values	0111 1111: +122 mG/°C 1000 0000: -122 mG/°C
Options	No fine magnetic offset is applied if this parameter is not set.
Examples	–

TC1_SENS_CLD (Register Address: 0x09, bits 15:8)**TC1_SENS_HOT (Register Address: 0x09, bits 23:16)**

Function	1st Order Sensitivity Temperature Coefficient. Specifies a compensation factor for drift in device Sensitivity resulting from changes in ambient temperature during operation. Applies a 1st order, linear compensation algorithm. Two different parameters are set, one for increasing values relative to $T_A = 25^\circ\text{C}$, and the other for decreasing values, as follows: <ul style="list-style-type: none"> • TC1_SENS_HOT: ΔT_A (from 25°C) > 0 • TC1_SENS_CLD: ΔT_A (from 25°C) < 0
Syntax	Quantity of bits: 8 (each parameter)
Related Commands	SENS_MULT, TC2_SENS_HOT, TC2_SENS_CLD
Values	1100 0000: -98 m%/°C 1011 1111: +291 m%/°C Increments (step size) of ± 1.53 m%/°C
Options	Set all bits to 0 if TC1_SENS_HOT and TC1_SENS_CLD are not used.
Examples	Refer to Temperature Compensation section.

TC2_SENS_CLD (Register Address: 0x08, bits 14:6)

TC2_SENS_HOT (Register Address: 0x08, bits 23:15)

Function	<p>2nd Order Sensitivity Temperature Coefficient. Specifies a compensation factor for drift in device Sensitivity resulting from changes in ambient temperature during operation. Applies a 2nd order, quadratic compensation algorithm. Two different parameters are set, one for increasing values relative to $T_A = 25^\circ\text{C}$, and the other for decreasing values, as follows:</p> <ul style="list-style-type: none"> • TC2_SENS_HOT: ΔT (from 25°C) > 0 • TC2_SENS_CLD: ΔT (from 25°C) < 0
Syntax	Quantity of bits: 9 (each parameter)
Related Commands	SENS_MULT, TC1_SENS_HOT, TC1_SENS_CLD
Values	<p>1 0000 0000: $-1.53 \text{ m}\% / ^\circ\text{C}$ 0 1111 1111: $+1.53 \text{ m}\% / ^\circ\text{C}$ Increments (step size) of $\pm 0.00596 \text{ m}\% / ^\circ\text{C}$</p>
Options	Set all bits to 0 if TC2_SENS_HOT and TC2_SENS_CLD are not used.
Examples	Refer to Temperature Compensation section.

DEFINITIONS OF TERMS

Power-On Time, t_{PO}

The time required for device output to settle within $\pm 10\%$ of its steady state value, after the power supply has reached its minimum specified operating voltage, $V_{CC}(\text{min})$. When the supply is ramped to its operating voltage, the device requires a finite time to power internal circuits before supplying a valid output value. See Figure 13.

Response Time, t_{RESP}

The time interval between a) when the applied magnetic field reaches 90% of its final intensity, and b) when the device output reaches 90% of its change corresponding to the magnetic field change. See Figure 14. Response time is affected by the programmed bandwidth, f_{3dB} , for the DSP stage.

Quiescent Voltage Output (QVO), $V_{OUT(Q)}$

The output value in the quiescent state (when no magnetic field is applied, $B_{IN} = 0$ G).

Sensitivity, Sens

The proportion of the output voltage to the magnitude of the applied magnetic field. This proportionality is specified as the Sensitivity, Sens (mV/G), and is effectively the gain of the device.

Magnetic Offset Drift Through Temperature Range

Due to internal component tolerances and thermal considerations, the magnetic offset may drift from its expected value, $B_{OFFEXPECTED}$, when changes occur in the operating ambient temperature, T_A . For purposes of specification, the Offset Drift Through Temperature Range, $\Delta B_{OFF(TC)}$, is defined as:

$$\Delta B_{OFF(TC)} = \frac{B_{OFF(TA)} - B_{OFFEXPECTED(TA)}}{B_{OFFEXPECTED(TA)}} \times 100 (\%) \quad (1)$$

where $B_{OFF(TA)}$ is the actual magnetic offset at the current ambient temperature, and $B_{OFFEXPECTED(TA)}$ is the magnetic offset calculated based on factory programmed parameters.

The Offset Temperature Coefficient can be seen as a representation of the offset drift over temperature in units mV/°C:

$$\Delta V_{OUT} = \frac{V_{OUT(Q)TA} - V_{OUT(Q)25^\circ C}}{T_A - 25^\circ C} \quad (2)$$

where V_{OUT} is measured quiescent output value at temperature T_A .

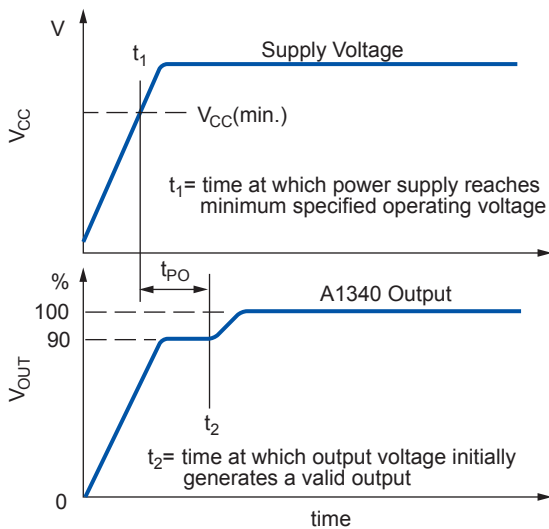

Figure 13: Definition of Power-On Time

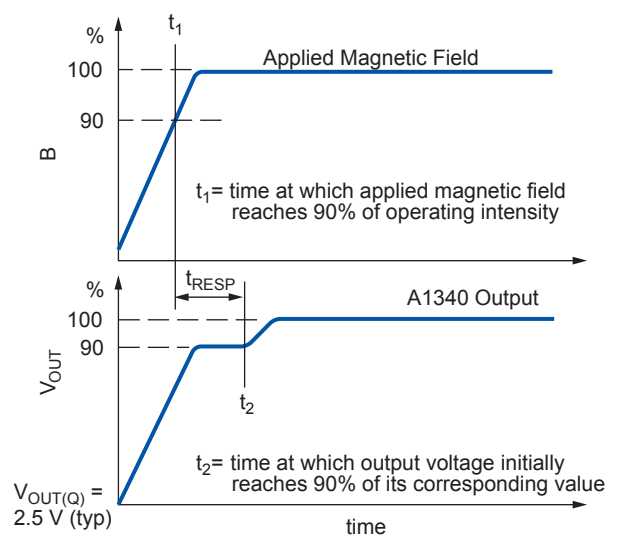

Figure 14: Definition of Response Time

Sensitivity Drift Through Temperature Range

Due to internal component tolerances and thermal considerations, the Sensitivity may drift from its expected value, $Sens_{EXPECTED}$, when changes occur in the operating ambient temperature, T_A . For purposes of specification, the Sensitivity Drift Through Temperature Range, $\Delta Sens_{TC}$, is defined as:

$$\Delta Sens_{TC} = \frac{Sens_{T_A} - Sens_{EXPECTED(T_A)}}{Sens_{EXPECTED(T_A)}} \times 100 (\%) \quad (3)$$

where $Sens_{T_A}$ is the actual Sens at the current ambient temperature, and $Sens_{EXPECTED(T_A)}$ is the Sens calculated based on factory programmed parameters.

The Sensitivity Temperature Coefficient can be seen as a representation of the Sensitivity drift in %/°C when a temperature divider, $\Delta T = T_A - 25^\circ C$, is inserted into equation 3.

Sensitivity Drift Due to Package Hysteresis, $\Delta Sens_{PKG}$

Package stress and relaxation can cause the device sensitivity at $T_A = 25^\circ C$ to change during and after temperature cycling. For purposes of specification, the Sensitivity Drift Due to Package Hysteresis, is defined as:

$$\Delta Sens_{PKG} = \frac{Sens_{(25^\circ C)2} - Sens_{(25^\circ C)1}}{Sens_{(25^\circ C)1}} \times 100 (\%) \quad (4)$$

where $Sens_{(25^\circ C)1}$ is the programmed value of Sensitivity at $T_A = 25^\circ C$, and $Sens_{(25^\circ C)2}$ is the value of Sensitivity at $T_A = 25^\circ C$, after temperature cycling.

Linearity Sensitivity Error

The A1340 is designed to provide a linear output in response to a ramping applied magnetic field. Consider two magnetic field strengths, B1 and B2. Ideally, the sensitivity of a device is the same for both field strengths, for a given supply voltage and temperature. Linearity error is present when there is a difference between the sensitivities measured at B1 and B2.

Linearity Error is calculated separately for the positive (Lin_{ERRPOS}) and negative (Lin_{ERRNEG}) applied magnetic fields. Linearity error is measured and defined as:

$$\begin{aligned} Lin_{ERRPOS} &= \left(1 - \frac{Sens_{B_X}}{Sens_{B_X/2}} \right) \times 100 (\%) \\ Lin_{ERRNEG} &= \left(1 - \frac{Sens_{-B_X}}{Sens_{-B_X/2}} \right) \times 100 (\%) \end{aligned} \quad (5)$$

where:

$$Sens_{B_X} = \frac{|V_{OUT(B_X)} - V_{OUT(Q)}|}{B_X} \quad (6)$$

and B_X and $-B_X$ are positive and negative magnetic fields

Final Linearity Sensitivity Error (Lin_{ERR}) is the maximum value of the absolute positive and absolute negative linearization errors. Note that unipolar devices only have positive linearity error (Lin_{ERRPOS}).

Ratiometric

The A1340 features ratiometric output. This means that the quiescent voltage output, $V_{OUT(Q)}$, magnetic sensitivity, Sens, and clamp voltage, V_{OUTCLP} , are proportional to the supply voltage, V_{CC} .

The ratiometric change in the quiescent output voltage, $Rat_{V_{OUT(Q)}} (\%)$, is defined as:

$$Rat_{V_{OUT(Q)}} = \frac{V_{OUT(Q)V_{CC}} / V_{OUT(Q)5V}}{V_{CC} / 5V} \times 100 (\%) \quad (7)$$

the ratiometric change in sensitivity is defined as:

$$Rat_{SENS} = \frac{Sens_{V_{CC}} / Sens_{5V}}{V_{CC} / 5V} \times 100 (\%) \quad (8)$$

and the ratiometric change in clamp voltage is defined as:

$$Rat_{V_{CLP}} = \frac{V_{CLP(V_{CC})} / V_{CLP(5V)}}{V_{CC} / 5V} \times 100 (\%) \quad (9)$$

Note that clamping effect is applicable only when clamping is enabled by programming of the device.

CUSTOMER PACKAGE DRAWING

For Reference Only - Not for Tooling Use

(Reference DWG-9202)

Dimensions in millimeters - NOT TO SCALE

Dimensions exclusive of mold flash, gate burs, and dambar protrusions

Exact case and lead configuration at supplier discretion within limits shown

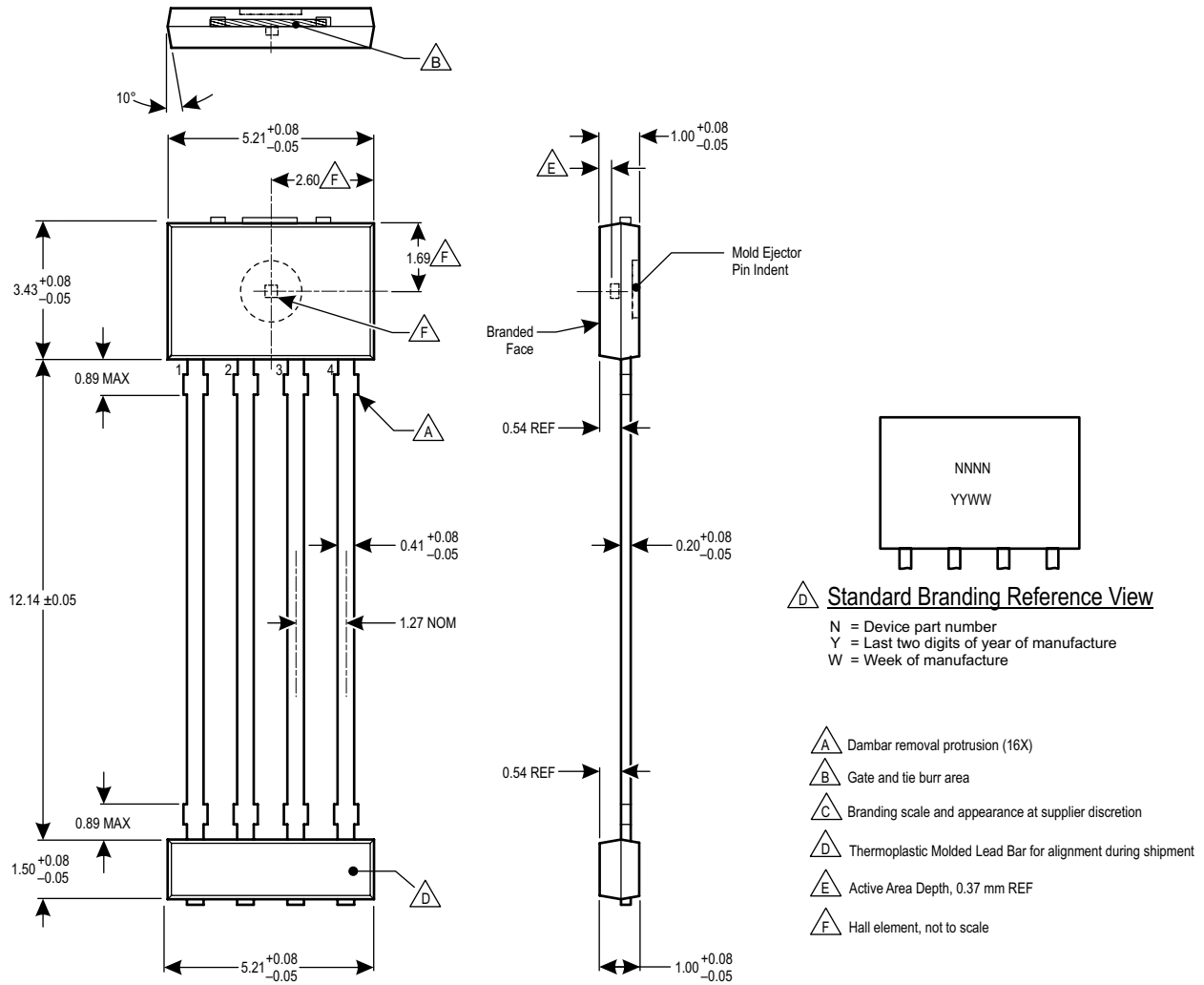

Figure 15: Package KT, 4-Pin SIP

Revision History

Revision	Revision Date	Description of Revision
–	September 16, 2014	Initial Release
1	December 2, 2014	Revised Selection Guide
2	February 12, 2015	Revised Package Drawing
3	January 4, 2018	Updated part status to not for new design
4	September 10, 2018	Updated part status to pre-end-of-life
5	January 25, 2019	Updated part status to last-time buy

Copyright 2019, Allegro MicroSystems.

Allegro MicroSystems reserves the right to make, from time to time, such departures from the detail specifications as may be required to permit improvements in the performance, reliability, or manufacturability of its products. Before placing an order, the user is cautioned to verify that the information being relied upon is current.

Allegro's products are not to be used in any devices or systems, including but not limited to life support devices or systems, in which a failure of Allegro's product can reasonably be expected to cause bodily harm.

The information included herein is believed to be accurate and reliable. However, Allegro MicroSystems assumes no responsibility for its use; nor for any infringement of patents or other rights of third parties which may result from its use.

Copies of this document are considered uncontrolled documents.

For the latest version of this document, visit our website:

www.allegromicro.com