

Position Sensor IC with Speed and Direction Output

FEATURES AND BENEFITS

- Allegro SM package with integrated EMC components reduces need for external EMI protection
- Integrated back-biasing rare-earth pellet
- Digital output with speed and direction information provides ferromagnetic target position information
- Enhanced algorithms provide low jitter and high output accuracy performance
- Center of package switching alignment
- EEPROM programming for performance optimization and production traceability
- Electrical offset compensation through chopper stabilization
- Zero-crossing switching with internal hysteresis
- Robust test coverage capability using Scan Path and IDDQ measurement

PACKAGE:



3-pin SIP (suffix SM)

Not to scale

DESCRIPTION

The ATS696PSM is a combined Hall-effect sensor IC and EMC protection circuit that provides a user-friendly PCB-less solution for true zero-speed digital crankshaft sensing. The ATS696 provides speed and direction information through a variable pulse-width output protocol. The open-drain output provides a voltage output such that the time between falling electrical edges (period) corresponds to the speed, and the time between a falling edge and corresponding rising edge (pulse width) indicates direction. The device can be optimized via programmable options for crankshaft sensing applications and can be used to sense a ferromagnetic target.

Three Hall plates are used to create three differential channels. These channels, along with advanced direction detection algorithms, are used to produce a highly accurate output across the full range of air gap and operating temperatures. The combination of high accuracy with direction information provides absolute position on most crank targets in cases of engine backlash, making it ideal for stop/start engine designs.

The ATS696 is provided in a 3-pin SIP package (SM) that is lead (Pb) free, with 100% tin leadframe plating.

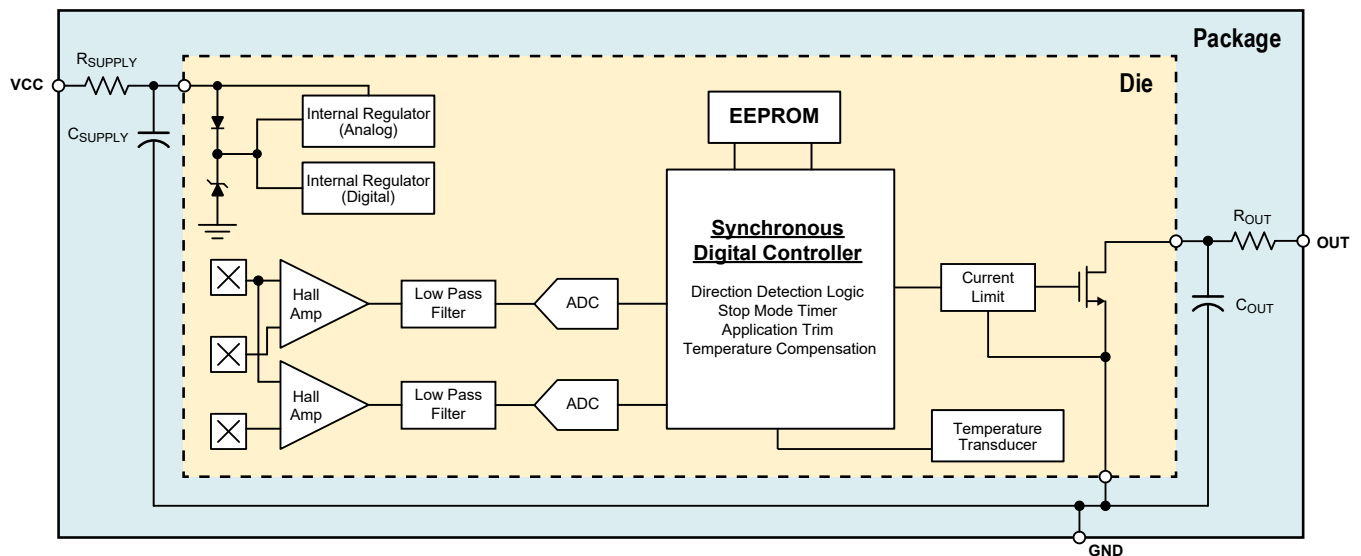

Figure 1: Functional Block Diagram

ATS696PSM Position Sensor IC with Speed and Direction Output

SELECTION GUIDE [1]

Part Number	Packing*
ATS696PSMTN-RNBPMG-D	Tape and reel, 800 pieces per 13 inch reel
ATS696PSMTN-RNBPMG	

[1] Not all combinations are available. Contact Allegro sales for pricing and availability of custom programming options.

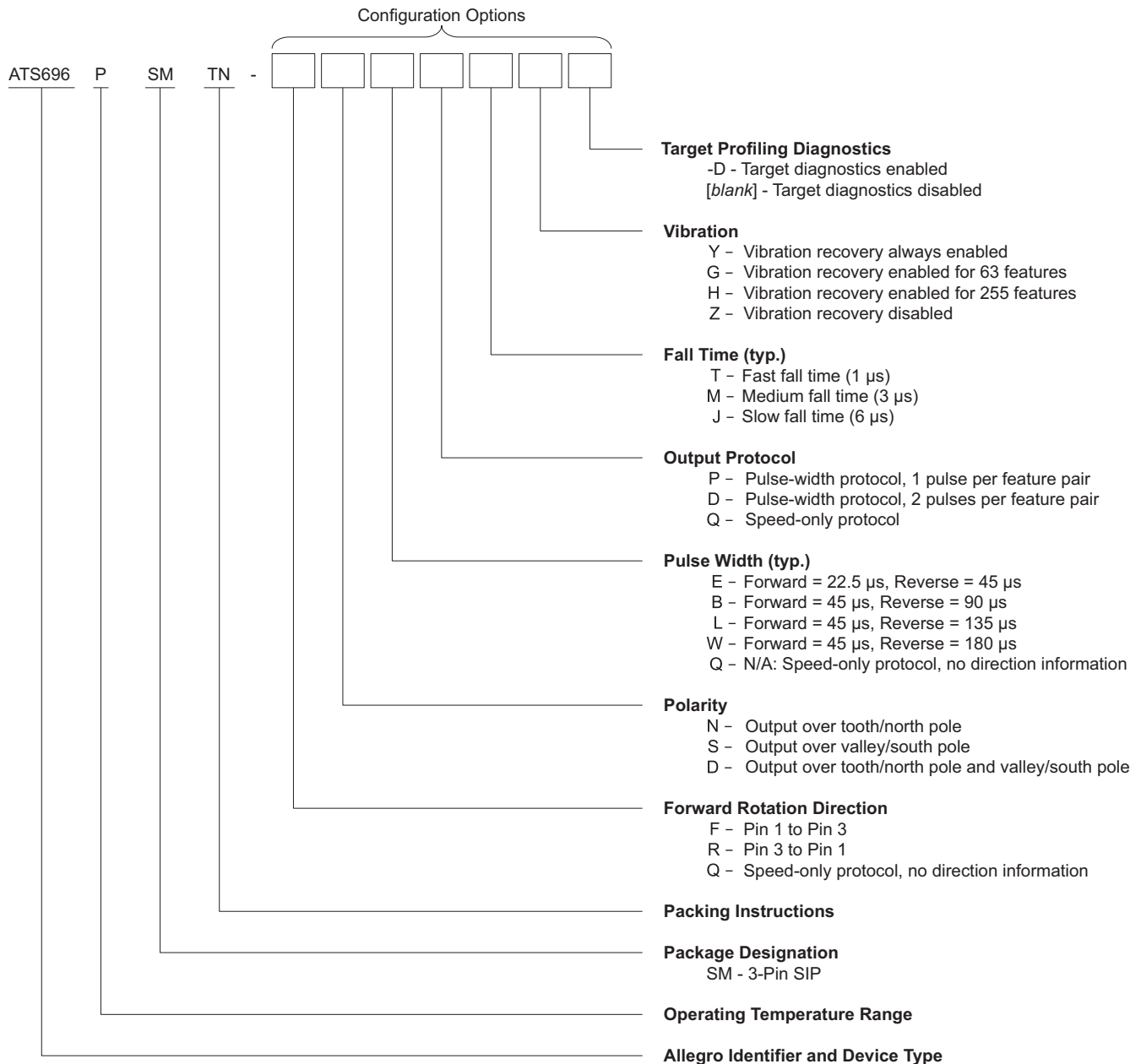

ATS696PSM Position Sensor IC with Speed and Direction Output

ABSOLUTE MAXIMUM RATINGS

Characteristic	Symbol	Notes	Rating	Unit
Supply Voltage	V_{CC}	Refer to Power Derating Section	27	V
Reverse Supply Voltage	V_{RCC}		-18	V
Reverse Supply Current	I_{RCC}		50	mA
Reverse Output Voltage	V_{ROUT}	$R_{PU} \geq 1 \text{ k}\Omega$	-0.5	V
Output Sink Current	$I_{OUTSINK}$	Internal current limiting	25	mA
Operating Ambient Temperature	T_A	Range P	-40 to 160	$^{\circ}\text{C}$
Maximum Junction Temperature	$T_{J(max)}$		175	$^{\circ}\text{C}$
Storage Temperature	T_{stg}		-65 to 170	$^{\circ}\text{C}$

INTERNAL DISCRETE COMPONENT RATINGS

Symbol	Characteristic	Rating	Unit
C_{SUPPLY}	Nominal Capacitance	220000	pF
C_{OUT}	Nominal Capacitance	2200	pF
R_{SUPPLY}	Nominal Resistance	33	Ω
R_{OUT}	Nominal Resistance	20	Ω

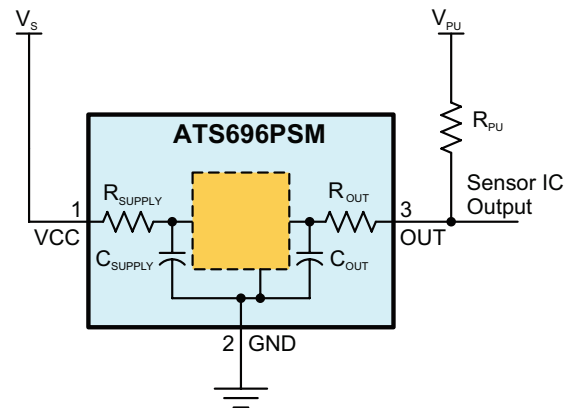
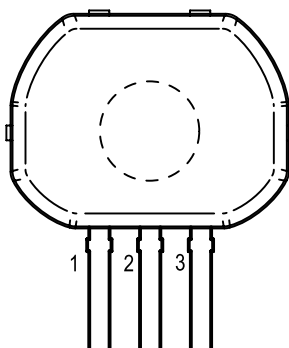

Figure 2: Minimum Application Circuit

Pinout Diagram



Terminal List

Number	Name	Function
1	VCC	Supply voltage
2	GND	Ground
3	OUT	Device output



ATS696PSM Position Sensor IC with Speed and Direction Output

OPERATING CHARACTERISTICS: T_A and V_{CC} within specification, unless otherwise noted

Characteristics	Symbol	Test Conditions	Min.	Typ.	Max.	Unit	
ELECTRICAL CHARACTERISTICS							
Supply Voltage	V_{CC}	Operating, $T_J < T_{J(max)}$	4.5	–	24	V	
Supply Current	I_{CC}		–	13	15	mA	
Supply Zener Clamp Voltage	$V_{Zsupply}$	$I_{CC} = I_{CC(MAX)} + 3 \text{ mA}$	27	–	–	V	
Reverse Supply Zener Clamp Voltage	$V_{RZsupply}$	$I_{CC} = -3 \text{ mA}$	–	–	-18	V	
POWER-ON CHARACTERISTICS							
Power-On State	POS		off (high voltage)			–	
Power-On Time	t_{PO}	$f_{OP} < 100 \text{ Hz}$, $V_{CC} > V_{CC(MIN)}$	–	–	1	ms	
OUTPUT STAGE							
Output On Voltage	$V_{OUT(SAT)}$	Output = on state, $I_{SINK} = 5 \text{ mA}$	–	–	300	mV	
		Output = on state, $I_{SINK} = 20 \text{ mA}$	–	–	950	mV	
Output Off Voltage	$V_{OUT(OFF)}$	Continuous	–	–	24	V	
Output Zener Clamp Voltage	$V_{Zoutput}$	$I_{OUT} = 3 \text{ mA}$	27	–	–	V	
Output Current Limit	$I_{OUT(LIM)}$	$V_{OUT} = 12 \text{ V}$, $T_J < T_{J(max)}$	30	60	80	mA	
Output On Current	$I_{OUT(ON)}$		0	–	25	mA	
Output Leakage Current	$I_{OUT(OFF)}$	$V_{OUT} = 18 \text{ V}$, Output = off state ($V_{OUT} = \text{High}$)	–	–	10	μA	
Pulse Width (t_W) [1]	$t_{W(FWD)}$	Forward running mode; measured at 50%; $R_{PU} = 1 \text{ k}\Omega$, $V_{PU} = 5 \text{ V}$	Option F45	38.3	45	51.7	μs
			Option F22	19.3	22.5	25.7	μs
	$t_{W(REV)}$	Reverse running mode; measured at 50%; $R_{PU} = 1 \text{ k}\Omega$, $V_{PU} = 5 \text{ V}$	Option R90	76.5	90	103.5	μs
			Option R135	114.8	135	155.2	μs
			Option R180	153	180	207	μs
			Option R45	38.3	45	51.7	μs
Pulse Width Ratio [2]	$t_{W(REV)} / t_{W(FWD)}$	$V_{PU} = 5 \text{ V}$, $R_{PU} = 1 \text{ k}\Omega$; measured at 50%	1.7	2.0	2.4	–	
Minimum Separation Between Consecutive Output Pulses	t_{OUTsep}	Includes separation between pulses during a direction change	Option F45	30.6	36	41.4	μs
			Option F22	15.3	18	20.7	μs
Output Rise Time	t_r	10%-90%, $R_{PU} = 1 \text{ k}\Omega$	–	6	–	μs	
Output Fall Time	t_f	Measured 90% to 10% of V_{OUT} ; $V_{PU} = 5 \text{ V}$, $R_{PU} = 1 \text{ k}\Omega$	Fast Option	0.37	0.70	0.99	μs
			Medium Option	1.6	3	4.25	μs
			Slow Option	3.09	5.80	8.22	μs
Output Delay Time [3]	t_d	1 kHz sinusoidal input signal (default fall time option)	14	17	20	μs	

[1] Pulse widths measured at 50% threshold on both rising and falling edges.

[2] This is the pulse width ratio for the default pulse width options of $t_{W(FWD)} = 45 \mu\text{s}$ and $t_{W(REV)} = 90 \mu\text{s}$.

[3] Time between magnetic signal switch point crossing and electrical output signal reaching 90% of $V_{OUT(High)}$.

ATS696PSM Position Sensor IC with Speed and Direction Output

OPERATING CHARACTERISTICS: T_A and V_{CC} within specification, unless otherwise noted

Characteristics	Symbol	Note	Min.	Typ.	Max.	Unit	
PERFORMANCE CHARACTERISTICS							
Air Gap Range		Using Allegro 60-0 reference target; tested at 1000 rpm [4]	0.5	–	2.5	mm	
Switch Point	$V_{PROC(ST)}$	Speed Channel, Standard target programmable option; see Figure 5	45	50	55	% V_{pk-pk}	
		Speed Channel, Wide tooth target programmable option; see Figure 5	63.75	68.75	73.75	% V_{pk-pk}	
Internal Hysteresis	$V_{PROC(hys)}$	Speed Channel, one-sided; see Figure 5	–	12.5	–	% V_{pk-pk}	
Relative Repeatability	$err_{\theta E}$	Sinusoidal signal with 6-degree period; $f_{IN} = 1000$ Hz at 100 G_{pk-pk} ; 3σ ; (Standard Target Type Option)	–	–	0.025	degrees	
Input LPF Frequency	BW	Multi-pole, –3 dB point	–	15	–	kHz	
Operating Frequency	$f_{IN(FWD)}$	Correct Speed Information (Forward Rotation) (Option 22 or 45 μs Forward Pulse)	0	–	10	kHz	
	$f_{IN(REV)}$	Correct Speed Information (Reverse Rotation)	Option R45	0	–	10	kHz
			Option R90	0	–	6	kHz
			Option R130	0	–	4	kHz
		Option R180	0	–	3	kHz	
Absolute Phase Error During Calibration		Forward Rotation	$-0.25 \times T_{TARGET}^{[5]}$		$0.25 \times T_{TARGET}$	–	
		Reverse Rotation	$-0.5 \times T_{TARGET}$		$0.5 \times T_{TARGET}$	–	
Chopper Frequency	f_C		–	250	–	kHz	
Stop Mode Timer Period	t_{SM}	Timer interval to initiate Stop Mode; no sensed magnetic edges	–	5	–	s	
Time to First Output Edge	$t_{OUT(init)}$	After t_{PO} elapses, $f_{IN} < 600$ rpm	–	$T_{TARGET}^{[5]}$	–	–	
Missed or Extra Output Pulses in Running Mode	err_{OUT}		–	–	0	output pulse	
Direction Change Recognition	N_{CD}		–	1	–	switching feature	
Mechanical Shift of Switch Point	d_{ST}	Distance from target feature center to IC center when V_{PROCST} occurs	–	0	–	mm	
Runout		$B_{SEQ(min)} / B_{SEQ(max)}$; does not include Signature Region	0.50	–	–	–	

[4] Speed-related effects on maximum air gap are highly dependent upon specific target geometry. Consult with Allegro field applications engineering for aid with assessment of target geometries.

[5] See Figure 4 for the definition of T_{TARGET} .

ATS696PSM Position Sensor IC with Speed and Direction Output

OPERATING CHARACTERISTICS: T_A and V_{CC} within specification, unless otherwise noted

Characteristics	Symbol	Note	Min.	Typ.	Max.	Unit	
PERFORMANCE CHARACTERISTICS (continued)							
Cycle to Cycle Variation		$B_{SEQ(n)}$ to $B_{SEQ(n+1)}$, does not include signature region; see Figure 6	0.9	–	1.1	–	
Signature Amplification Ratio		$B_{SEQ(sig)} / B_{SEQ}$ of pole pair directly before signature region; see Figure 6	0.8	–	2.0	–	
Vibration Tolerance During Calibration		Periods of single-direction rotation required to provide correct output after start-up vibration is encountered [6]	–	–	3	periods (tooth-valley pairs)	
Initial Calibration Interval	CAL _I	$f_{IN} < 600$ rpm; no signature region	–	–	4	output pulse	
		$f_{IN} < 600$ rpm; signature region encountered	–	–	9	output pulse	
First Output Edge		After power on, $f_{IN} < 600$ rpm	–	T _{TARGET}	–	–	
TARGET CHARACTERISTICS							
Required Direction Channel Separation	B _{CHSEP}	Measured between the two direction channels; Measurement is made on normalized (0 to 100%) differential magnetic signals (see Target Definition section)	Opposite switching feature, measured at BST on Speed Channel, See Figure 10	35 [7]	–	–	%
			Opposite non-switching feature	0 [8]	–	–	%

[6] Incorrect Direction Pulses may be given during vibration events.

[7] Assumes Standard target option. For Wide tooth programmable option, minimum required Direction channel separation opposite a switching feature is 25%; see Programmable Options Table.

[8] No signal crossover, $0.25 \times B_{SEQ(MAX)} < B_{IN} < 0.75 \times B_{SEQ(MAX)}$.

ATS696PSM Position Sensor IC with Speed and Direction Output

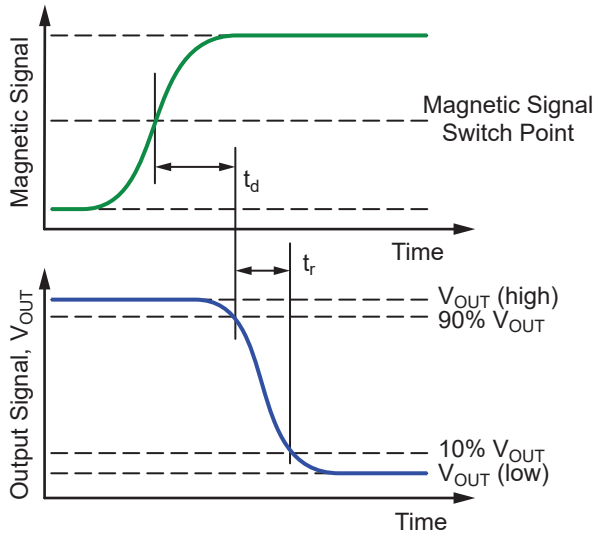
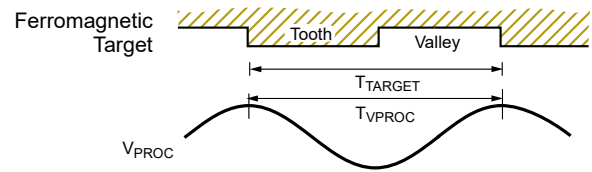

Figure 3: Definition of Output Fall Time and Delay Time



V_{PROC} = the processed analog signal of the sinusoidal magnetic input (per channel)
 T_{TARGET} = period between successive sensed target magnetic edges of the same polarity (for a ferromagnetic target, both rising or both falling mechanical edges)

Figure 4: Definition of T_{TARGET}

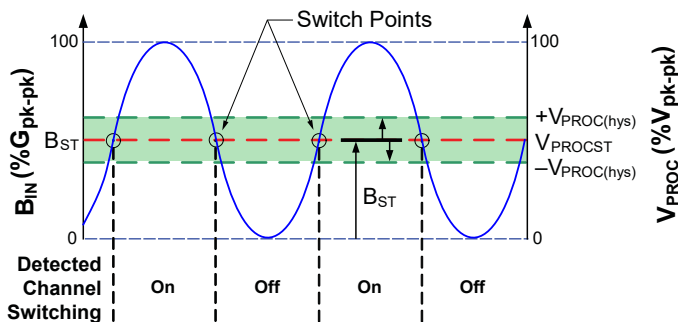

Figure 5: Establishment of Thresholds, Using Internal Hysteresis (Speed Channel)

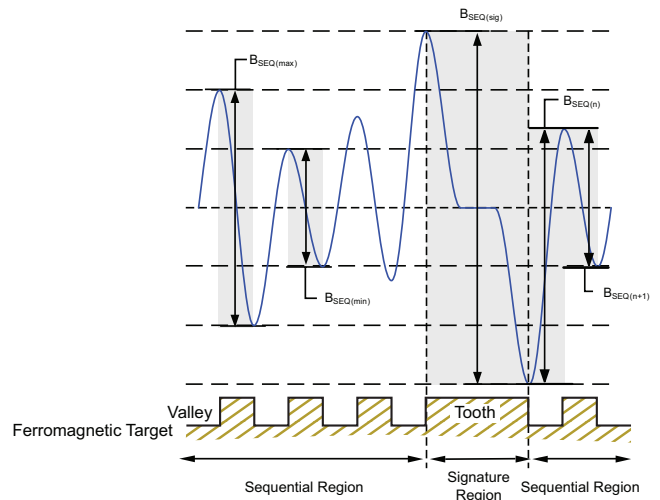
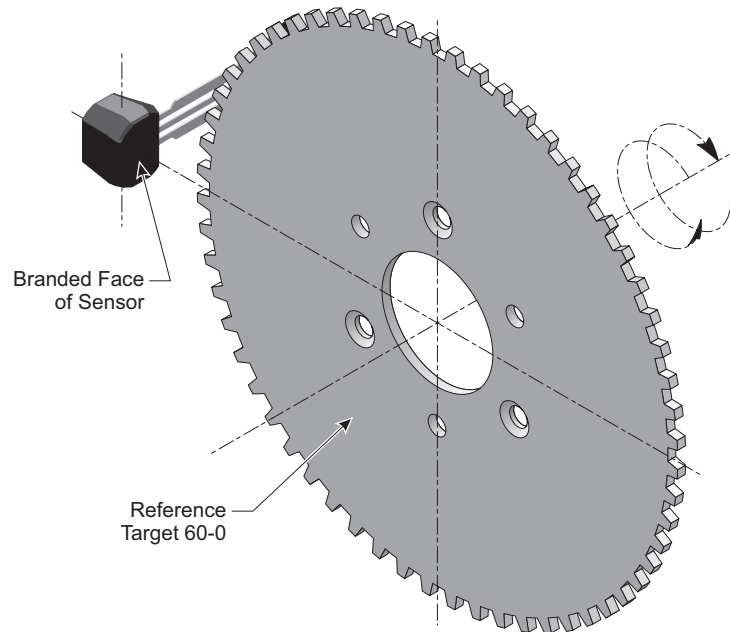

Figure 6: Differential Signature Amplification and Sequential Signal Variation

ATS696PSM Position Sensor IC with Speed and Direction Output

Reference Target 60-0 (60 Tooth Target)

Characteristics	Symbol	Test Conditions	Typ.	Units	Symbol Key
Outside Diameter	D_o	Outside diameter of target	120	mm	
Face Width	F	Breadth of tooth, with respect to branded face	6	mm	
Circular Tooth Length	t	Length of tooth, with respect to branded face	3	deg.	
Circular Valley Width	t_v	Length of valley, with respect to branded face	3	deg.	
Tooth Whole Depth	h_t		3	mm	
Material		Low Carbon Steel	-	-	



ATS696PSM Position Sensor IC with Speed and Direction Output

FUNCTIONAL DESCRIPTION

Sensing Technology

The sensor IC contains three Hall elements used in three differential pairs to provide an electrical output signal containing information regarding target edge position and direction of rotation.

Target Profiling

After proper power is applied to the sensor IC, it is capable of providing digital information that is representative of the mechanical or magnetic features of a rotating target. The waveform diagrams in Figure 7 present the automatic translation of

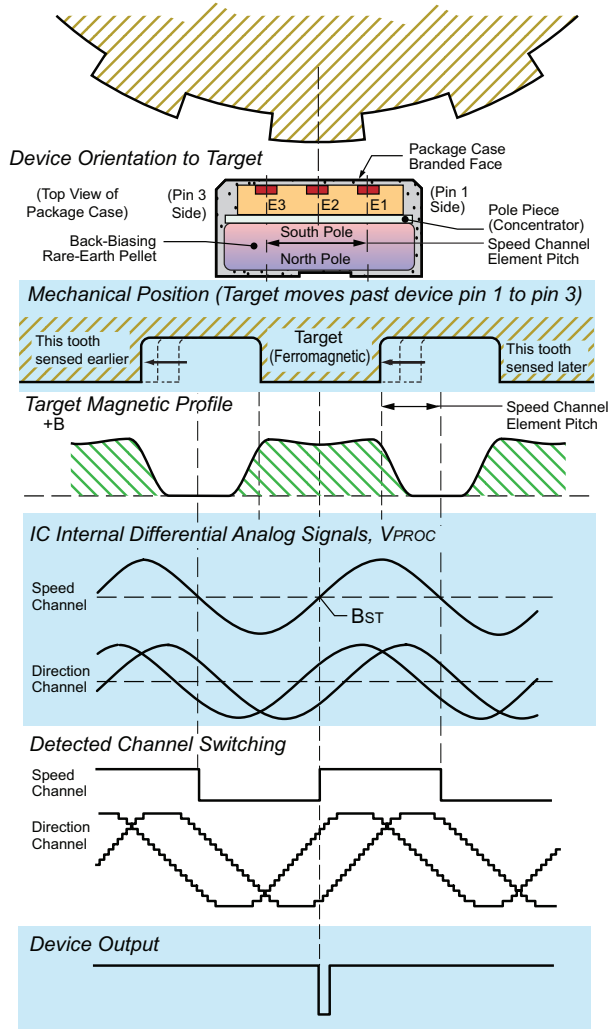

Figure 7: Magnetic Profile.
The magnetic profile reflects the features of the target, allowing the sensor IC to present an accurate digital output.

the target profiles, from their induced magnetic profiles to the digital output signal of the sensor IC. Three differential magnetic profiles are used to determine the location of the switching feature as well as the direction of rotation. While the location of the switching feature is determined from the differential magnetic profile (referred to as the speed channel), the direction of rotation is determined by the relative amplitude comparison of two low resolution normalized direction channels.

Direction Detection

The sensor IC compares the relative amplitude values of the two low resolution normalized direction signals at the speed channel switch point location to determine which direction the target is rotating. The direction of rotation is then communicated through the output pulse width. While in calibration mode, direction information is not available. As a result of this, forward output pulses ($t_{W(FWD)}$) are always given in calibration, independent of the true target rotation direction.

NOTE: For proper functionality, the output must be programmed such that the signature region is a non-switching feature (see Application Information section).

The sensor IC can be programmed such that the output will provide forward pulses ($t_{W(FWD)}$) when the target rotation is from pin 1 to pin 3 (Option F) or from pin 3 to pin 1 (Option R). This is illustrated in Figure 8, with the arrow on the target indicating direction of rotation.

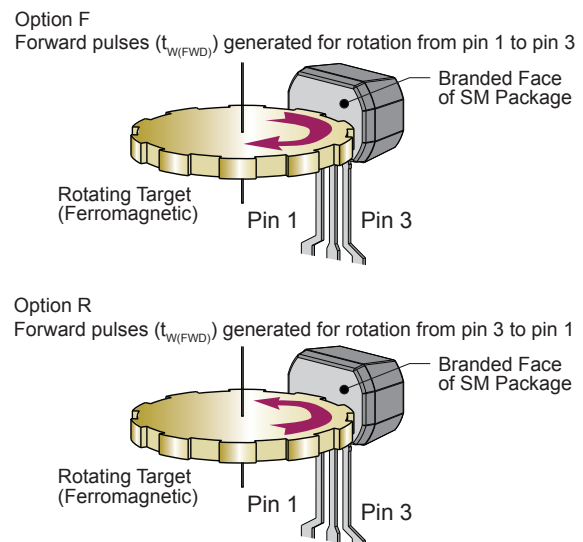

Figure 8: Rotation Direction Definitions

ATS696PSM Position Sensor IC with Speed and Direction Output

Pulse Occurrence Location

The output pulse can be programmed to occur at the target mechanical features of either polarity, i.e., at the center of a tooth (Option N) or at the center of a valley (Option S) with a ferromagnetic target.

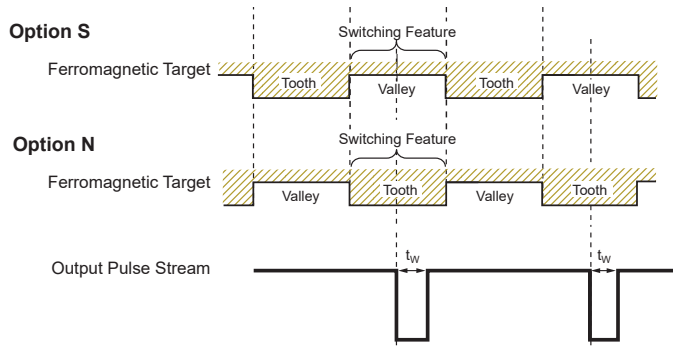

Figure 9: Output Pulse Location

Switch Points

The switchpoints of the ATS696 are established dynamically as a percentage of the amplitude of the internal signal V_{PROC} ; see Figure 5. This is accomplished by using two tracking signals to track the peaks of each V_{PROC} channel, and the switching thresholds are established at fixed percentages of the two tracking signals. Due to the switch point thresholds being established dynamically as a percentage of the peak-to-peak signal, the effect of a signal shift is minimized. The position of the output switching threshold on the speed channel is programmable to ensure the most accurate and consistent output switching. Additionally, it allows the ATS696 to properly detect direction of rotation when used with targets containing signature regions. A 50% threshold is recommended for standard crank targets, while the other programmable options allow for functionality on targets with different mechanical geometries.

Operating Modes

STARTUP HYSTERESIS

When the part is powered on, the first mode of operation is startup hysteresis mode. While in startup hysteresis, the sensor IC begins to internally detect the magnetic profile of the target. This operating mode is used to ensure the detected magnetic signal amplitude exceeds the minimum gauss threshold for the ATS696 algorithm to function properly. The required magnetic

signal amplitude is programmable such that it can be optimized for the application, (see the Programmable Options Table). A forward pulse ($t_{W(FWD)}$) is given if the magnetic signal amplitude meets the minimum requirements and the part powered on over a switching feature.

CALIBRATION MODE

Once it is determined that the magnetic signal amplitude meets the minimum signal requirements, the ATS696 begins its calibration. The calibration period allows the internal signal tracking algorithms to properly acquire the magnetic signals.

While in calibration mode, direction information is not available. As a result of this, forward output pulses ($t_{W(FWD)}$) are always given on speed channel switch point crossings, independent of the true target rotation direction. This pulse width is programmable to meet specific application requirements (see Programmable Options table).

RUNNING MODE

After calibration is complete, the target relative rotation direction information is available. This information is communicated through the variable pulse-width protocol. While forward rotation is indicated with pulses of width $t_{W(FWD)}$, reverse rotation is indicated with pulses of width $t_{W(REV)}$. The width of the forward pulse ($t_{W(FWD)}$) and the reverse pulse ($t_{W(REV)}$) can be programmed for application-specific performance optimization (see Programmable Options table). Additionally, see the Direction Detection section for a description of the target's relative direction of rotation.

In running mode, signal tracking algorithms are employed, allowing the ATS696 to track signal drift resulting from temperature changes, as well as the tracking of target variations such as pole-to-pole variation and runout, while still maintaining high accuracy output switching.

The ATS696 provides a tolerance to vibration during calibration. If the part satisfies the calibration criteria on target vibration, the part will recover once normal rotation begins. The vibration recovery algorithm allows the part to recover within three periods (tooth-valley pairs). The quantity of consecutive monodirectional pulses that vibration recovery is available for is programmable; see Programmable Options table. For the standard option of 63, once the 63rd consecutive pulse in a single direction is given, vibration recovery can no longer be tripped until the part is reset.

ATS696PSM Position Sensor IC with Speed and Direction Output

STOP & GO MODE

In certain engine management applications, it is possible for large temperature changes to occur while the target is stationary. These temperature changes can affect the differential magnetic signals. The Stop & Go algorithm compensates for such shifts in the processed signal. Once normal rotation resumes, the part will return to running mode.

APPLICATION INFORMATION

Power Supply Protection

The ATS696 contains an on-chip regulator and can operate across a wide supply voltage range. Figure 2 shows the minimum external circuitry needed for proper operation of the sensor IC. This ease of use reduces design time and incremental assembly costs for most applications. Contact Allegro MicroSystems for information on EMC specification compliance.

Target Design

The ATS696 is designed to provide highly accurate switching at each switching feature detected, including switching at the first switching feature after power-on, as well as at the first switching feature after a reversal in the direction of target rotation. To support this functionality, the target must generate a trio of differential magnetic profiles, such that the two direction channels have discernible leading/lagging characteristics. The direction of rotation is determined by comparing the spatial separation between the differential magnetic profiles of the two direction channels.

SIGNAL DIFFERENTIATION AT SWITCHING FEATURES

The optimal separation between the profiles of the two differential direction signals occurs when the corresponding magnetic profiles are in quadrature; this is illustrated in Figure 10. Quadrature profiles can be achieved when the target pitch of the switching feature is approximately equal to twice the distance between the midpoints of the two direction channels, that is, the distance between the midpoint of Hall elements E1 and E2 and the midpoint of Hall elements E2 and E3. This equates to 2.5 mm.

For the ATS696, a switching feature can either be magnetic north and/or magnetic south of a gear tooth peak/valley depending on the Output Pulse Location. This translates to either a positive or negative slope on the Speed channel magnetic signal, and the output switching occurs at the BST point. The BST point is programmable depending on target type; see Programmable Options Table.

Either differential direction channel can be leading or lagging the other, depending on the relative direction of target rotation. When a switching feature is adjacent to the device, i.e., the Speed channel crosses the BST point, the difference between the differential direction signals must be at least 30% of the peak-to-peak amplitude in the sequential regions, B_{SEQ} . The difference between the differential direction signals is programmable depending on target type; see Programmable Options Table. The sequential region refers to the target areas where the switching features are periodic and of uniform configuration, and therefore generating a consistent magnetic profile; see Figure 6.

NON-SWITCHING FEATURES

When non-switching features are adjacent to the device, the constraints on the differential magnetic signals are less stringent, because no output pulses are generated. However, channel signal separation greater than zero must be maintained so that the leading/lagging relationship of the differential magnetic signals is not reversed.

USE OF SIGNATURE REGIONS

Signature regions are target features that are disproportionately long relative to the sequential features. As a result, they can generate differential signal peaks that differ from the peaks generated by the sequential regions; see Figure 6. The device accommodates these peaks and switching occurs at relatively the same switch point as on the sequential features. The effect of a signature region would be a delay in reaching the next switch point.

The extension of the signal period significantly reduces the slope of the magnetic gradient around the midpoint of a signature feature. In fact, for relatively large signature features, the magnetic gradient can become flat, as shown in Figure 6. The flat magnetic signal also makes it difficult to maintain the necessary channel separation required for a switching feature. For these reasons, the device accommodates only signature features that are non-switching features.

ATS696PSM Position Sensor IC with Speed and Direction Output

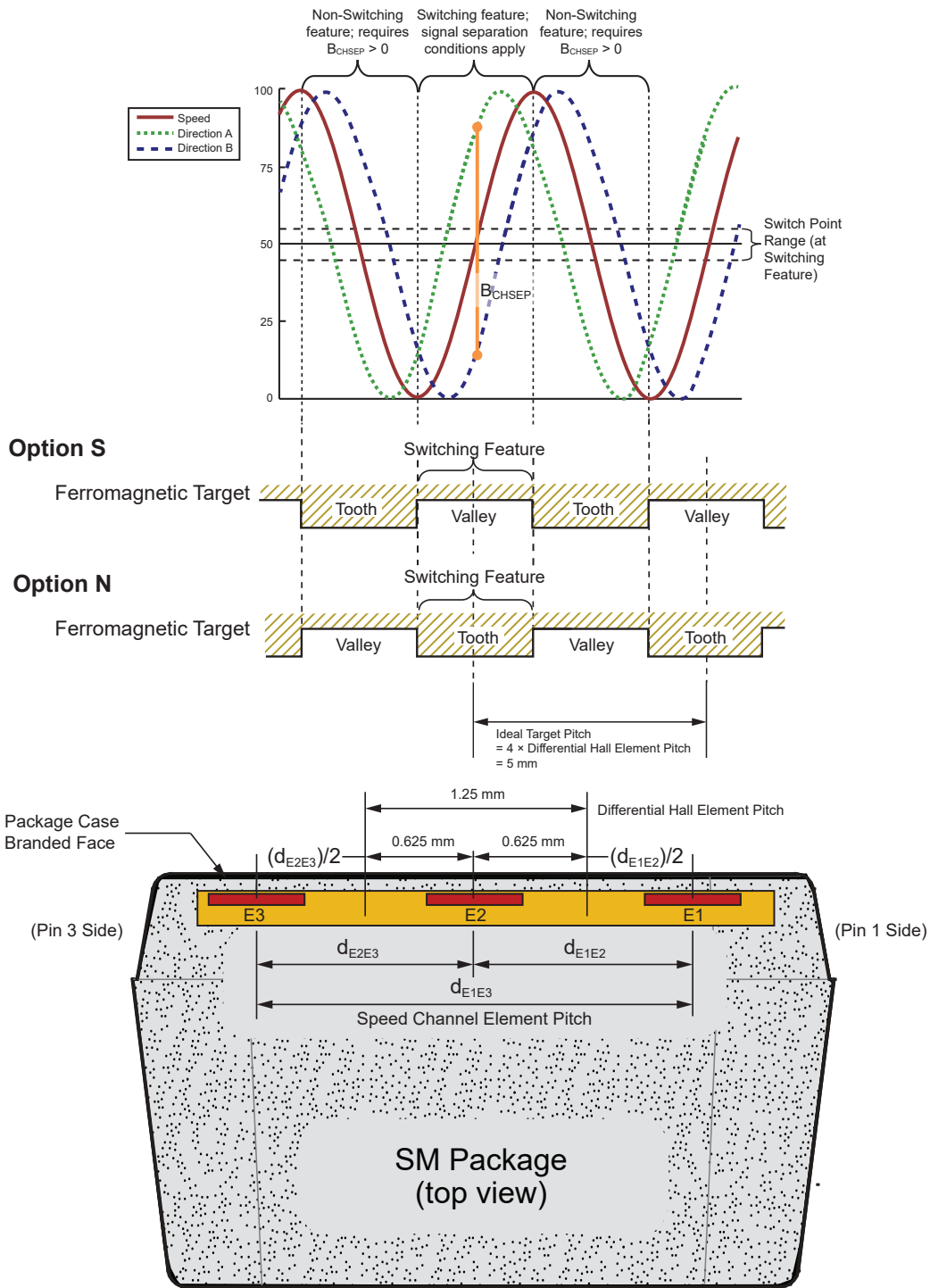

Figure 10: Channel Separation and Signal Inversion Definitions

ATS696PSM Position Sensor IC with Speed and Direction Output

POWER DERATING

The device must be operated below the maximum junction temperature of the device, $T_{J(max)}$. Under certain combinations of peak conditions, reliable operation may require derating supplied power or improving the heat dissipation properties of the application. This section presents a procedure for correlating factors affecting operating T_J . (Thermal data is also available on the Allegro MicroSystems website.)

The Package Thermal Resistance, $R_{\theta JA}$, is a figure of merit summarizing the ability of the application and the device to dissipate heat from the junction (die), through all paths to the ambient air. Its primary component is the Effective Thermal Conductivity, K , of the printed circuit board, including adjacent devices and traces. Radiation from the die through the device case, $R_{\theta JC}$, is a relatively small component of $R_{\theta JA}$. Ambient air temperature, T_A , and air motion are significant external factors, damped by overmolding.

The effect of varying power levels (Power Dissipation, P_D), can be estimated. The following formulas represent the fundamental relationships used to estimate T_J , at P_D .

$$P_D = V_{IN} \times I_{IN} \quad (1)$$

$$\Delta T = P_D \times R_{\theta JA} \quad (2)$$

$$T_J = T_A + \Delta T \quad (3)$$

For example, given common conditions such as: $T_A = 25^\circ\text{C}$, $V_{CC} = 12\text{ V}$, $I_{CC} = 7\text{ mA}$, and $R_{\theta JA} = 134^\circ\text{C/W}$, then:

$$P_D = V_{CC} \times I_{CC} = 12\text{ V} \times 7\text{ mA} = 84\text{ mW}$$

$$\Delta T = P_D \times R_{\theta JA} = 84\text{ mW} \times 134^\circ\text{C/W} = 11.3^\circ\text{C}$$

$$T_J = T_A + \Delta T = 25^\circ\text{C} + 11.3^\circ\text{C} = 36.3^\circ\text{C}$$

A worst-case estimate, $P_{D(max)}$, represents the maximum allowable power level ($V_{CC(max)}$, $I_{CC(max)}$), without exceeding $T_{J(max)}$, at a selected $R_{\theta JA}$ and T_A .

Example:

Reliability for V_{CC} at $T_A = 150^\circ\text{C}$, estimated values based on package SM, using single layer PCB.

Observe the worst-case ratings for the device, specifically: $R_{\theta JA} = 134^\circ\text{C/W}$, $T_{J(max)} = 165^\circ\text{C}$, $V_{CC(absmax)} = 24\text{ V}$, and $I_{CC} = 12\text{ mA}$.

Calculate the maximum allowable power level, $P_{D(max)}$. First, invert equation 3:

$$\Delta T_{(max)} = T_{J(max)} - T_A = 165^\circ\text{C} - 150^\circ\text{C} = 15^\circ\text{C}$$

This provides the allowable increase to T_J resulting from internal power dissipation. Then, invert equation 2:

$$P_{D(max)} = \Delta T_{(max)} \div R_{\theta JA} = 15^\circ\text{C} \div 134^\circ\text{C/W} = 111.9\text{ mW}$$

Finally, invert equation 1 with respect to voltage:

$$V_{CC(est)} = P_{D(max)} \div I_{CC} = 111.9\text{ mW} \div 12\text{ mA} = 9.3\text{ V}$$

The result indicates that, at T_A , the application and device can dissipate adequate amounts of heat at voltages $\leq V_{CC(est)}$.

Compare $V_{CC(est)}$ to $V_{CC(max)}$. If $V_{CC(est)} \leq V_{CC(max)}$, then reliable operation between $V_{CC(est)}$ and $V_{CC(max)}$ requires enhanced $R_{\theta JA}$. If $V_{CC(est)} \geq V_{CC(max)}$, then operation between $V_{CC(est)}$ and $V_{CC(max)}$ is reliable under these conditions.

THERMAL CHARACTERISTICS: May require derating at maximum conditions

Characteristic	Symbol	Test Conditions*	Value	Unit
Package Thermal Resistance	$R_{\theta JA}$	1-layer PCB with copper limited to solder pads	134	$^\circ\text{C/W}$

*Additional thermal information available on the Allegro website.

ATS696PSM Position Sensor IC with Speed and Direction Output

Package SM, 3-Pin SIP

For Reference Only – Not for Tooling Use

(Reference DWG-0000417, Rev. 3)

Dimensions in Millimeters – NOT TO SCALE

Dimensions exclusive of mold flash, gate burrs, and dambar protrusions
Exact case and lead configuration at supplier discretion within limits shown

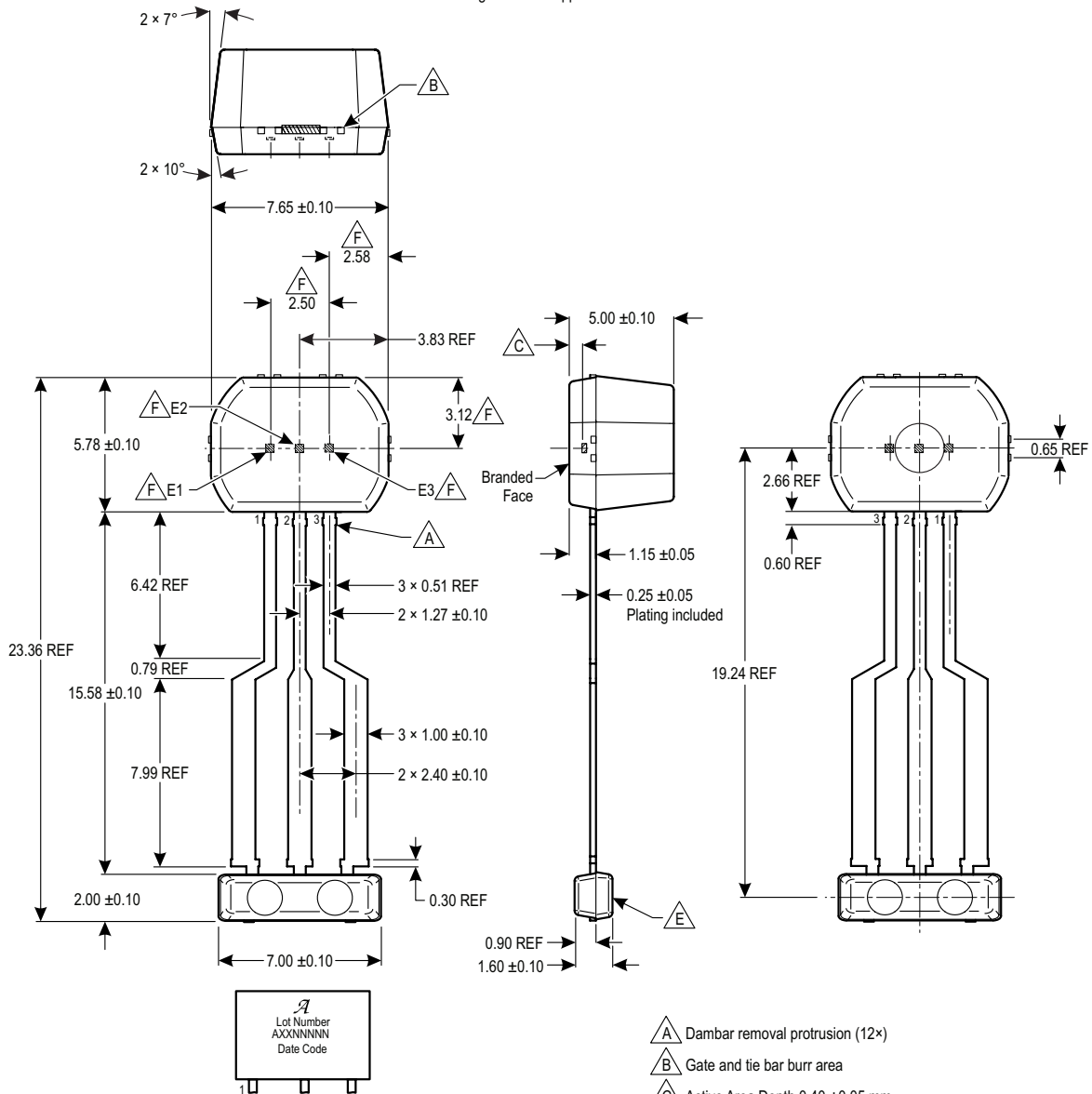

Standard Branding Reference View

Lines 1, 2, 3, 4: Max. 10 characters per line

Line 1: Logo A

Line 2: Characters 5, 6, 7, 8, 9, 10, 11 of
Assembly Lot Number

Line 3: Part Number

Line 4: 4-digit Date Code

- Dambar removal protrusion (12x)
- Gate and tie bar burr area
- Active Area Depth 0.40 ± 0.05 mm
- Branding scale and appearance at supplier discretion
- Molded lead bar for preventing damage to leads during shipment
- Hall elements (E1, E2, and E3), not to scale

ATS696PSM Position Sensor IC with Speed and Direction Output

Revision History

Number	Date	Description
–	October 26, 2018	Initial release
1	February 22, 2021	Updated Selection Guide and minor editorial updates
2	October 7, 2021	Updated package abbreviation (page 2); removed Sleep Mode (pages 4 and previously pages 11, 13, 14)
3	January 21, 2022	Added Air Gap Range to Performance Characteristics (page 5), removed Magnetic Characteristics (page 6), and added Reference Target (page 8)

Copyright 2022, Allegro MicroSystems.

Allegro MicroSystems reserves the right to make, from time to time, such departures from the detail specifications as may be required to permit improvements in the performance, reliability, or manufacturability of its products. Before placing an order, the user is cautioned to verify that the information being relied upon is current.

Allegro's products are not to be used in any devices or systems, including but not limited to life support devices or systems, in which a failure of Allegro's product can reasonably be expected to cause bodily harm.

The information included herein is believed to be accurate and reliable. However, Allegro MicroSystems assumes no responsibility for its use; nor for any infringement of patents or other rights of third parties which may result from its use.

Copies of this document are considered uncontrolled documents.

For the latest version of this document, visit our website:

www.allegromicro.com